

2521/105, 2602/106

2601/106, 2603/106

ELECTRICAL MEASUREMENTS AND
ANALOGUE ELECTRONICS I

June/July 2017

Time: 3 hours



THE KENYA NATIONAL EXAMINATIONS COUNCIL

DIPLOMA IN ELECTRICAL AND ELECTRONIC ENGINEERING
(POWER OPTION)
(TELECOMMUNICATION OPTION)
(INSTRUMENTATION OPTION)
MODULE I

ELECTRICAL MEASUREMENTS AND ANALOGUE ELECTRONICS I

Edunotes.co.ke
3 hours

INSTRUCTIONS TO CANDIDATES

You should have the following for this examination:

Answer booklet

Mathematical table/Non-programmable scientific calculator;

Drawing instruments.

This paper consists of EIGHT questions in TWO sections; A and B.

Answer any THREE questions from section A and any TWO questions from section B in the answer booklet provided.

All questions carry equal marks.

Maximum marks for each part of a question are as indicated.

Candidates should answer all questions in English.

This paper consists of 5 printed pages.

Candidates should check the question paper to ascertain that all the pages are printed as indicated and that no questions are missing.

© 2017 The Kenya National Examinations Council

Turn over

SECTION A: ELECTRICAL MEASUREMENTS

Answer any **THREE** questions from this section.

1. (a) (i) Describe the following standards with respect to measurements:
- (I) secondary;
 - (II) working.
- (ii) A standard cell has a voltage rating of 1.018500 V and internal resistance of 500Ω . If the insulation resistance between its terminals is $5\text{ M}\Omega$, determine the:
- (I) current drain due to insulation resistance;
 - (II) difference between the rated voltage and the drop due to internal resistance.
- (9 marks)
- (b) Derive the dimensional equation of "work done" in MLT system of units. (5 marks)
- (c) A voltmeter having a sensitivity of $1,000\ \Omega/\text{V}$ reads 100V on its 150V scale when connected across an unknown resistor in series with a milliammeter. Neglecting the milliammeter resistance, determine the percentage error due to the loading effect of the voltmeter when the milliammeter reads 5 mA. (6 marks)
2. (a) (i) State **one** source of error in wattmeters when used in measurements.
- (ii) With the aid of a labelled block diagram, describe the heterodyne method of frequency measurement. (7 marks)
- (b) A solenoid, 1.2 m long, is uniformly wound with 800 turns. A search coil of mean diameter 30 mm, wound with 50 turns, is placed at the centre of the solenoid and connected to a ballistic galvanometer. The total resistance of the search-coil circuit is 2000Ω . When a current of 5A through the solenoid is reversed, the deflection on the galvanometer scale is 85 divisions. Taking $\mu_0 = 4\pi \times 10^{-7}\text{ H/m}$, determine the ballistic constant of the galvanometer in coulombs/unit deflection. (13 marks)

3. (a) (i) Define reliability with respect to engineering systems.
- (ii) Sketch, on the same axis, the curves showing the manufacturing cost against reliability and explain the shape of each curve. (8 marks)
- (b) Outline the procedure of assessing the reliability of an equipment. (8 marks)
- (c) In a test of 400 diodes, 5 failed over a 1,000 hour period. For the diodes, determine the:
- (i) failure rate;
- (ii) mean time to fail. (4 marks)
4. (a) (i) State any **two** possible causes of open circuit fault in carbon composition resistors.
- (ii) Figure 1 shows a schematic block diagram of a d.c motor speed control system. Explain the effect of an open circuit fault in the feedback line and how it can be verified. (7 marks)

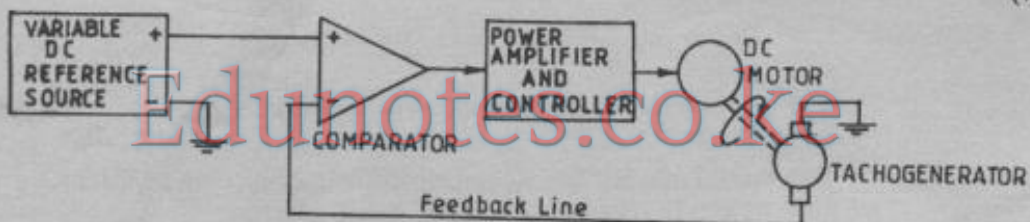

Fig. 1

- (b) With the aid of a labelled block diagram incorporating a signal generator and an oscilloscope, describe a test to determine the gain of a faulty audio amplifier. (7 marks)
- (c) In an electrical system, the probability (P_t) of the system being returned to working condition within a time of 4 hours is 86.5%. Determine the:
- (i) mean time to repair;
- (ii) failure rate. (6 marks)

5. (a) (i) Distinguish between instrumental errors and environmental errors with respect to measurements.
- (ii) With the aid of a circuit diagram, describe how a full-wave rectifier instrument is used to measure the r.m.s value of an a.c voltage. (9 marks)
- (b) (i) With the aid of a phasor diagram, show that the power measured by the two-wattmeter method in a 3-phase system gives the total power in the system. Assume the wattmeters are connected in the red and blue phases.
- (ii) In the measurement in b(i), the readings on each wattmeter is 5.2 kW and -1.7 kW. Determine the:
- (I) total power;
- (II) power factor. (11 marks)

SECTION B: ANALOGUE ELECTRONICS I

Answer any TWO questions from this section.

6. (a) (i) State any two merits of a full-wave centre-tapped single-phase rectifier.
- (ii) With the aid of a circuit diagram, describe the operation of a shunt capacitor filter. Sketch the output voltage waveform. (10 marks)
- (b) Show that the r.m.s. value, $V_{r(rms)}$, of the a.c. component of the rectified voltage from a full-wave diode rectifier equals $0.308 V_{peak}$. (6 marks)
- (c) A series dc-to-ac inverter has an inductor of 10 mH, a capacitor of $47 \mu\text{F}$ and a load resistor of 5Ω . Determine the:
- (i) resonant frequency;
- (ii) time period of oscillations (4 marks)

7. (a) (i) Define the following JFET parameters:
- (I) drain-source saturation current;
 - (II) gate-source cutoff (pinch-off) voltage.
- (ii) With the aid of a labelled construction diagram, describe the operation of an n-channel depletion MOSFET and sketch its output characteristic curves. (9 marks)
- (b) Figure 2 shows a circuit diagram of a transistor amplifier. For stability reasons, the current through R_2 must be ten times the base current. Taking $\beta = 100$, $V_{BE} = 0.7V$, $V_C = 8V$, $V_E = 2V$ and $I_C = 1mA$, determine the value of the bias resistors R_1 , R_2 , R_3 and R_4 . (11 marks)

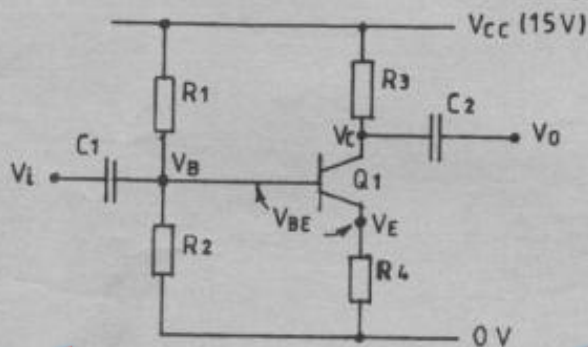

Fig. 2
Edunotes.co.ke

8. (a) (i) State any **two** of Bohr's postulates with respect to the energy levels of an electron. (8 marks)
- (ii) With the aid of a covalent bond diagram of an intrinsic semiconductor, explain how a hole takes part in conduction. (6 marks)
- (b) Sketch the characteristic curve of a p-n junction diode and explain its shape. (6 marks)
- (c) An electrostatic CRO has deflection plates of length, $l = 2$ cm and distance between them, $d = 3$ mm. It is operated at an anode voltage, $V_a = 2$ kV and deflection potential, $V_d = 150$ V. Taking electron charge, $e = 1.602 \times 10^{-19}C$ and electron mass, $m = 9.109 \times 10^{-31}$ kg, determine the:
- (i) velocity of the electron beam;
 - (ii) transit time through the plates;
 - (iii) electric field intensity between the plates. (6 marks)

THIS IS THE LAST PRINTED PAGE.