

2920/202B

COMPUTER APPLICATIONS II

July 2017

Time: 1 hour



THE KENYA NATIONAL EXAMINATIONS COUNCIL

DIPLOMA IN INFORMATION COMMUNICATION TECHNOLOGY

MODULE II

COMPUTER APPLICATIONS II

Practical

1 hour

INSTRUCTIONS TO CANDIDATES.

You have ten minutes to read through the instructions and questions before starting the examination. Any problem with the computer should be reported to the invigilator immediately. Direct any question(s) to the invigilator only. Conversing with fellow students may lead to disqualification.

Write your name and index number on the rewritable CD.

Type your name as a header on each sheet of paper used.

This paper consists of TWO tasks. Perform the TWO tasks.

Each task carries 20 marks.

Read the instructions of each task carefully.

Print on one side of the paper(s) only and use a fresh sheet of paper for each task.

Hand over your printout and the Rewritable CD to the invigilator at the end of the examination.

This paper consists of 5 printed pages.

Candidates should check the question paper to ascertain that all the pages are printed as indicated and that no questions are missing.

GENERAL INSTRUCTIONS TO CANDIDATES

1. Create a folder named **KNECEXAM** on the desktop.
2. Ensure that the **KNECEXAM** folder and all its content is burnt onto the Rewritable CD provided at the end of the examination.

Edunotes.co.ke

TASK 1

- (a) Open a CAD program and make the following settings as default: (½ mark)
- (i) Units: millimetres; (½ mark)
 - (ii) Precision: 0 decimal place. (½ mark)

- (b) Insert a layer with the following properties: (1 mark)

Layer name	Edges
line weight	0.6 mm

- (c) (i) Draw figure 1 as it appears on the layer created in (b) using the indicated dimensions. (11½ marks)

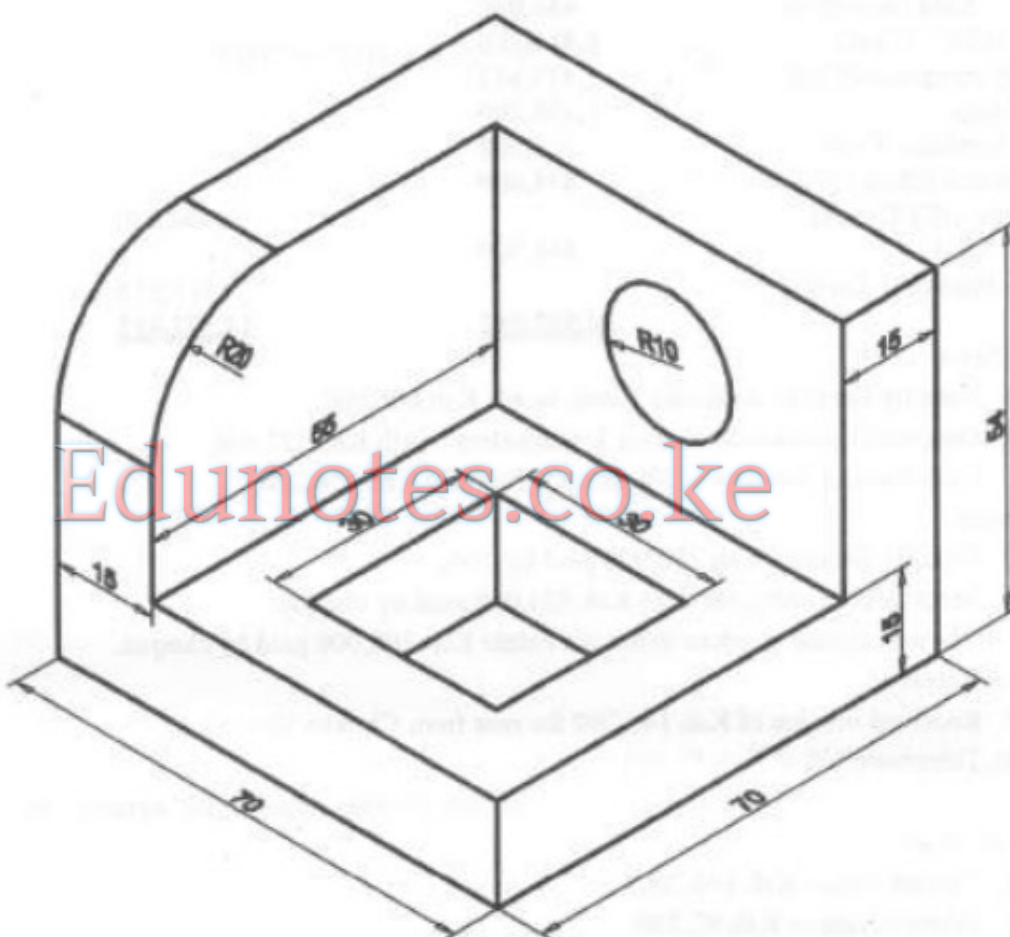

Figure 1

- (ii) Fully dimension the drawing. (5 marks)
- (d) Save the drawing as *3dgeometry* in the **KNECEXAM** folder. (½ mark)
- (e) Print out later each of the following views of the drawing.
- (i) The isometric view; (½ mark)
 - (ii) The front view. (½ mark)

TASK 2

Simba Services Ltd. of P.O. Box 2019-00800, Nairobi, is a security company hiring out guards, dogs and other security related services. Record the following financial details and transactions of the company using an appropriate accounting package, for the month of July 2016.

Trial balance as at 1st July, 2016

	DR (Ksh)	CR (Ksh)
Capital		4,200,000
Creditors :Koga Manufacturers		486,500
Debtors: Muga Supermarkets	381,000	
: Kalu University	484,000	
Motor vehicle (Cost)	8,416,200	
Security equipment(Cost)	2,435,612	
Patrol Dogs	1,456,200	
Office furniture (Cost)	203,500	
Fixtures and fittings (Cost)	874,600	
Bank loan (IFT Credit)		6,400,000
Cash in hand	346,700	
Cash at Bank(IFT Credit)		3,511,312
	<u>14,597,812</u>	<u>14,597,812</u>

Credit Sales

July 10 Security Services to Kauka Estate worth Ksh 806,000.

July 24 Dog patrol services to Kamili Transporters worth Ksh 312,400.

July 31 Cash transfer services to Muga Supermarkets Ksh 256,200.

Cash Sales

July 13 Security Services Ksh 240,000 paid by cash.

July 29 Security consulting services Ksh 424,000 paid by cheque.

July 31 Alarm response services to Kauka Estate Ksh 208,000 paid by cheque.

Invoices Received

July 20 Received invoice of Ksh 146,200 for rent from Chukan House.

July 25 Telephone bill of Ksh 83,400 from Safcom Kenya.

July 30 Security equipment maintenance bill of Ksh 105,000 from Digital Sytems Ltd.

Cash Payments

July 24 Chukan House Ksh 146,200.

July 26 Salary advances Ksh 92,300.

July 26 Safcom Kenya Ksh 83,400.

Cheque Payments

July 20 Koga Manufacturers Ksh 486,500.

July 24 Uzuri Furniture for purchase of office furniture Ksh 35,600.

Cheques Received

July 17 Muga Supermarkets Ksh 400,000.

July 22 Kauka Estate Ksh 806,000.

July 25 Kalu University Ksh 200,000.

Generate and print the following reports for the specified dates.

- (a) Trial balance as at 1st July 2016. (6 marks)
- (b) Profit and loss account for the month of July 2016. (6½ marks)
- (c) Cash flow statement for the month of July 2016. (7½ marks)

THIS IS THE LAST PRINTED PAGE.

Edunotes.co.ke