

2601/102 2603/102

2602/102

PHYSICAL SCIENCE, MECHANICAL SCIENCE
AND ELECTRICAL ENGINEERING PRINCIPLES

Oct./Nov. 2017

Time: 3 hours



20 DEC 2017

THE KENYA NATIONAL EXAMINATIONS COUNCIL

DIPLOMA IN ELECTRICAL AND ELECTRONIC ENGINEERING
(POWER OPTION)
(TELECOMMUNICATION OPTION)
(INSTRUMENTATION OPTION)

MODULE I

PHYSICAL SCIENCE, MECHANICAL SCIENCE AND ELECTRICAL
ENGINEERING PRINCIPLES

3 hours

Edunotes.co.ke

INSTRUCTIONS TO CANDIDATES

You should have the following for this examination:

Answer booklet;

Drawing instruments.

This paper consists of EIGHT questions in THREE sections; A and B and C.

Answer ONE question from section A, ONE question from section B and THREE questions from section C.

Maximum marks for each part of a question are indicated.

Candidates should answer the questions in English.

Take: $\mu_0 = 4\pi \times 10^{-2} \text{H/m}$

This paper consists of 8 printed pages.

Candidates should check the question paper to ascertain that all the pages are printed as indicated and that no questions are missing.

SECTION A: PHYSICAL SCIENCE

Answer **ONE** question from this section.

1. (a) (i) Define background radiations as used in radioactivity.
- (ii) State **four** sources of background radiations. (3 marks)
- (b) Outline **two** safety measures observed when handling radioactive materials. (2 marks)
- (c) A hydrocarbon of relative molecular mass 84, burns completely in excess oxygen to form 5.28 g of carbon (IV) oxide gas and 2.16 g of steam. Determine its:
- (i) empirical formula;
- (ii) molecular formula.
- Take R.A.M of C = 12, O = 16 and H = 1. (8 marks)
- (d) (i) Explain the term 'resonance' in relation to vibrating objects.
- (ii) Describe the energy changes in the LC circuit in figure 1. (7 marks)

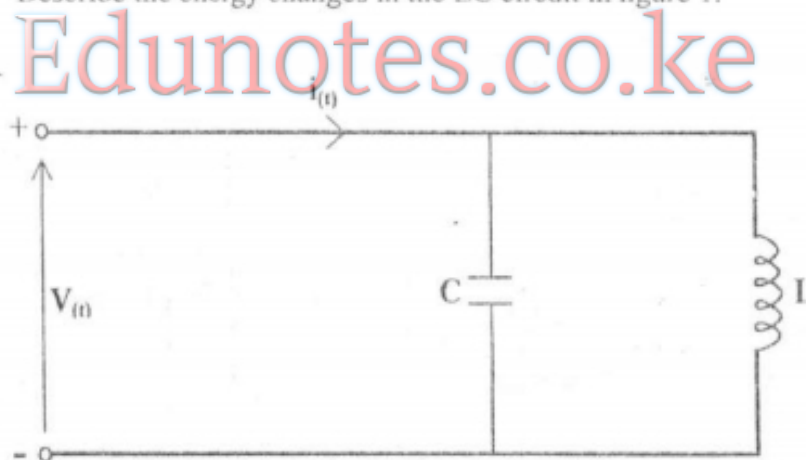

Fig. 1

2. (a) (i) Arrange the following ions in order of their position in the electrochemical series:
- (I) Lead, Zinc, Copper;
 (II) Hydroxide, Sulphate, Chloride.
- (ii) Differentiate between endothermic reaction and exothermic reaction, giving one example in each case. (6 marks)
- (b) Show the relationship between velocity, frequency and wavelength. (3 marks)
- (c) (i) Define ultrasound as used in acoustics.
- (ii) An echo sounder transmits sound wave to the bottom of a hydroelectric power dam and receives its echo after 1.2 seconds. The speed of sound in the water is 1500 m/s. Determine the depth of water in the dam. (4 marks)
- (d) (i) State two:
- (I) forms of heat transfer; *Codeword*
 (II) temperature scales. *°C, Kel Fahrenheit*
- (ii) 3000 g of water at 21° C was frozen to 0° C. Determine the heat lost. Take specific heat capacity of water as 4200 J kg⁻¹ K⁻¹, and specific latent heat of fusion of ice as 336 kJ/kg. (7 marks)

Edunotes.co.ke

SECTION B: MECHANICAL SCIENCE

Answer ONE question from this section.

3. (a) (i) State two forms of mechanical energy.
- (ii) A machine exerts a force of 240 N to move an object at a constant speed through a distance of 600 cm in 2 minutes. Determine its power. (4 marks)
- worked*
 $P = \frac{W}{Time} = \frac{F \cdot d}{T}$
- (b) (i) Name four types of coupling devices used in mechanical power transmission. *clutches*
- (ii) Explain how centrifugal governor controls the speed of an engine. (4 marks)
- clutches*

- (c) Figure 2 shows a system of co-planer forces acting concurrently in different directions. The resultant force is zero. Determine force F and angle α . (8 marks)

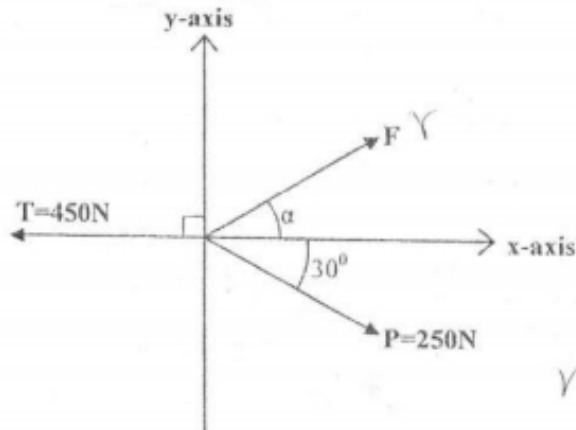

Fig. 2

$v \theta = v^2 / r$

- (d) (i) Define the following terms as used in thermodynamics:

- (I) phase;
- (II) cycle.

- (ii) Differentiate between 'pure' and 'working' thermodynamic substances.

(4 marks)

4. (a) (i) Define the following terms as applied to engineering materials:

- (I) hardness;
- (II) fatigue.

- (ii) A tensile force of 12 N acts on an aluminium wire of length 2 m and diameter 2.5 mm. The wire is stretched by 0.3 mm. Determine the:

- (I) stress;
- (II) strain in the wire.

(6 marks)

- (b) With the aid of a graph of uniform angular velocity against time, describe angular acceleration of a rotating object.

(3 marks)

- (c) A stationary object of mass 500 g is hit by a force, F lasting a period of 1.2 seconds. The object takes off at a velocity of 36 m/s. Determine the:

- (i) change in momentum;
- (ii) magnitude of the force F .

(4 marks)

u, v, t
p = mv
p = F t

Answer shift P

- (d) (i) State **four** causes of pressure drop in oil pipeline.
- (ii) Figure 3 shows venturi meter used to measure flow rate of oil in a horizontal pipe. The density of oil is 900 kg/m^3 . The difference in oil pressure in the wide and narrow sections is 110 N/m^2 . Determine the volume flow rate. (7 marks)

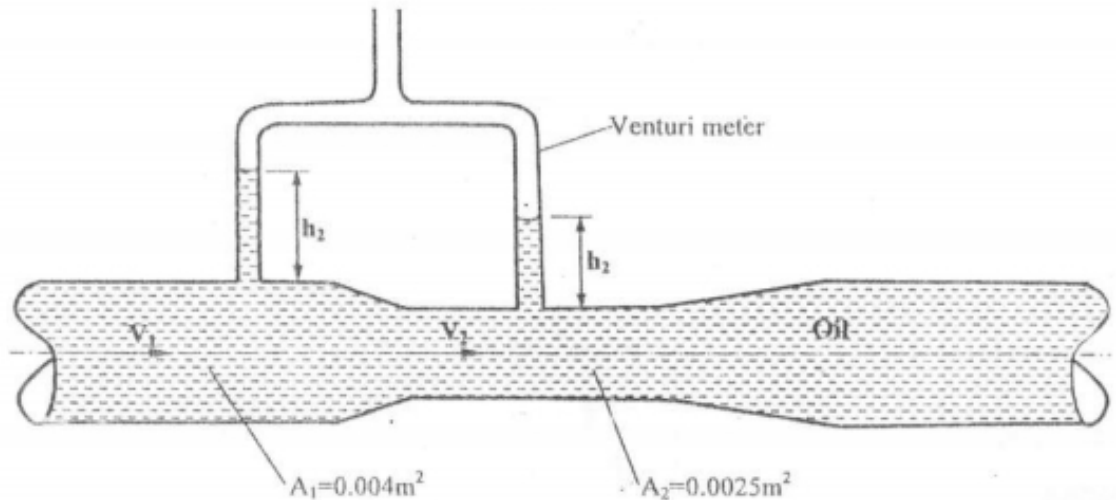

Fig. 3

Edunotes.co.ke

SECTION C: ELECTRICAL ENGINEERING PRINCIPLES

Answer **THREE** questions from this section.

- (5. 7) (a) (i) State the SI units associated with the following electrical quantities and classify each as either basic or derived unit:
- (I) conductance; - $\text{Resistor unit} = \frac{V}{A} = \Omega$
 (II) current; - Basic unit
- (ii) An electromagnet exerts a force of 12 N and moves a soft iron armature through a distance of 1.5 cm in 40 ms . Determine its power. (5 marks)
- (b) State two advantages and two disadvantages of alkaline cells over lead-acid cells. (4 marks)
- (c) Explain: - measure the voltage of the battery
- (i) The process of charging a secondary cell;
- (ii) Two precautions observed during battery charging. (6 marks)

- (d) Figure 4 shows a series-parallel arrangement of cells supplying a load current of 0.1 A. Each cell has an emf of 1.25 V and internal resistance of 0.1Ω . Determine the:

- (i) emf and internal resistance of the battery formed;
 (ii) load resistance.

(5 marks)

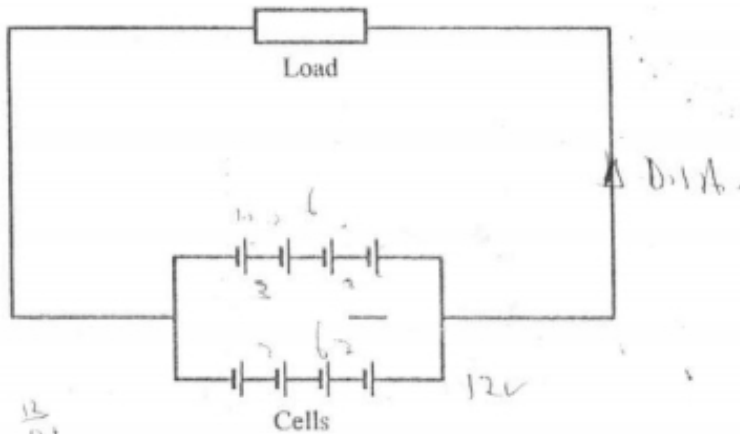

Fig. 4

6. (a) Differentiate between linear scale and non-linear scale as used in electrical instruments.

(2 marks)

- (b) (i) Explain the principle of operation of a moving-coil instrument.

- (ii) State **one** advantage of moving-iron instruments over moving-coil instruments.

(3 marks)

- (c) With the aid of labelled diagram, describe the operation of repulsion type moving-iron instrument.

(7 marks)

- (d) (i) State Kirchoff's laws.

- (ii) Figure 5 shows an electric circuit. Determine the:

- (I) current through 6Ω resistor;

- (II) voltage across 2Ω resistor.

(8 marks)

The algebraic sum of the products of current and resistance in a network plus the algebraic sum of the potential difference in that network is zero.

$$\sum IR + \sum E - \sum P = 0$$

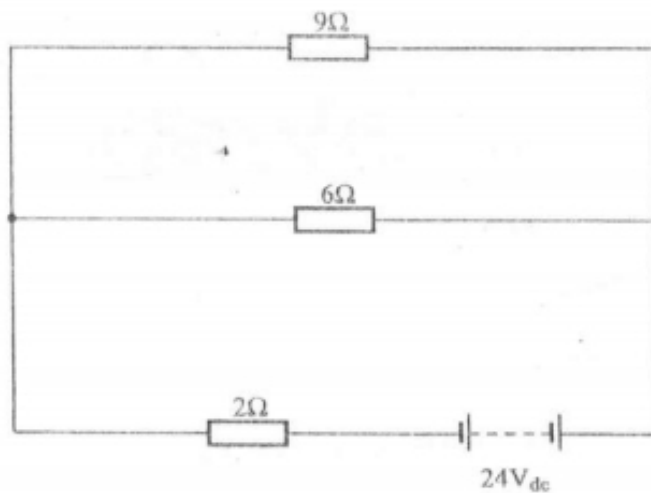
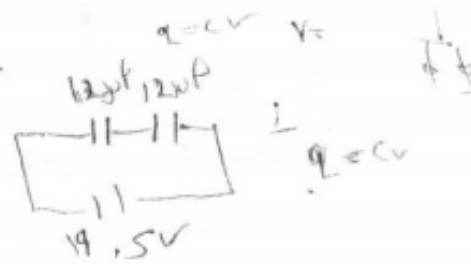

Fig. 5

7. (a) State **one** application of:

- (i) ceramic capacitor;
- (ii) variable air capacitor;
- (iii) electrolytic capacitor.



(3 marks)

(b) Two $12\mu F$ capacitors are connected in series. The voltage across the combination is $19.5V$. Determine the energy stored in each capacitor. (4 marks)

- (c) (i) Explain the term 'hysteresis' as applied in magnetic materials.
- (ii) With the aid of a diagram, describe the hysteresis loop for magnetic materials. (9 marks)

(d) Describe how the following occurs in magnetically coupled circuits:

- (i) self inductance;
- (ii) mutual inductance. (4 marks)

8. (a) Define the following terms as used in a.c supply:

- (i) period;
- (ii) frequency. (2 marks)

(b) An alternating voltage is given by the expression $V = 239 \sin(100\pi t - 0.25)$ volts. Determine the:

(i) peak to peak voltage;

(ii) rms voltage;

(iii) frequency;

(iv) phase angle.

(8 marks)

(c) Explain the purpose of laminating a transformer core.

(2 marks)

(d) A 5 kVA single-phase transformer has a turns ratio of 46:1 and is fed from a 11 kV, 50 Hz supply. Neglecting losses, determine the:

(i) secondary voltage on open circuit;

(ii) full-load secondary current;

(iii) minimum load resistance;

(iv) full-load primary current.

(8 marks)

Edunotes.co.ke

THIS IS THE LAST PRINTED PAGE.