

2920/202B
COMPUTER APPLICATIONS II
(PRACTICAL)
PAPER 2
November 2021
Time: 1 hours



THE KENYA NATIONAL EXAMINATIONS COUNCIL

DIPLOMA IN INFORMATION COMMUNICATION TECHNOLOGY

MODULE II

COMPUTER APPLICATIONS II (PRACTICAL)

Paper 2

Practical

1 hour

INSTRUCTIONS TO CANDIDATES.

You have ten minutes to read through the instructions and questions before starting the examination. Any problem with the computer should be reported to the invigilator immediately.

Direct any question(s) to the invigilator only. Conversing with fellow students may lead to disqualification.

Write your name and index number on the rewritable CD.

Type your name as a header on each sheet of paper used.

This paper consists of TWO tasks. Perform the TWO tasks.

Each task carries 20 marks.

Read the instructions of each task carefully.

Print on one side of the paper(s) only and use a fresh sheet of paper for each task.

Hand over your printout and the Rewritable CD to the invigilator at the end of the examination.

This paper consists of 6 printed pages.

Candidates should check the question paper to ascertain that all the pages are printed as indicated and that no questions are missing.

GENERAL INSTRUCTIONS TO CANDIDATES

1. Create a folder named **KNECEXAM** on the desktop.
2. Ensure that the **KNECEXAM** folder and all its content is burnt onto the Rewritable CD provided at the end of the examination.

easytvvet.com

TASK 1

(a) Open a CAD program and make the following as drawing settings:

(i) Units: millimetres;

(½ mark)

(ii) Precision: 0 decimal place;

(½ mark)

(b) Insert two layers each with the following properties:

(1 mark)

Layer name	Line weight
Edges	0.8 mm
Dimension	0.2 mm

(c) (i) Figure 1 shows a mechanical metal plate. Draw the figure as it appears on the *Edges* layer using the dimensions indicated.

(11 marks)

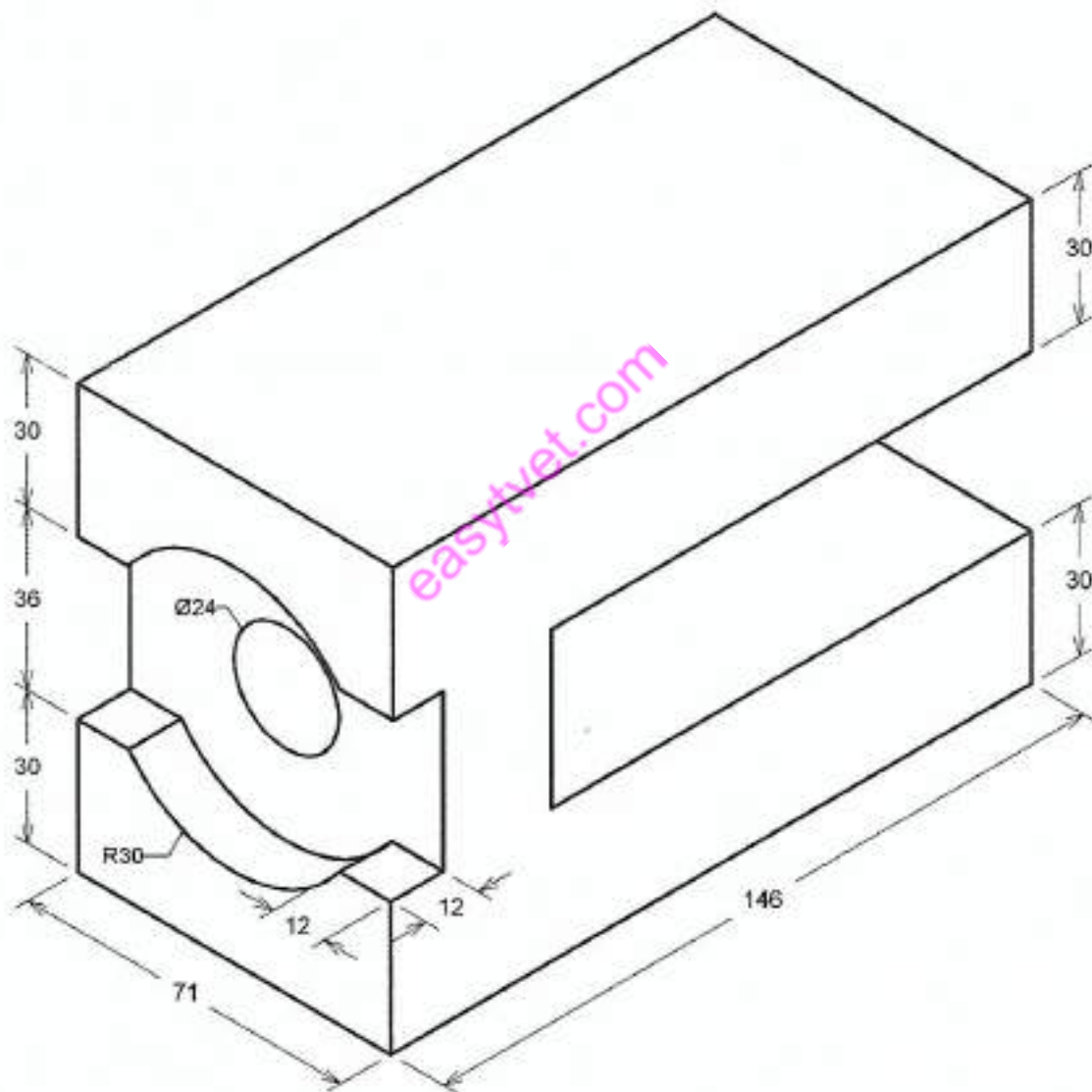

Figure 1

(ii) Fully dimension the drawing on the *dimension* layer.

(5 marks)

(d) Save the drawing as *mechanical plate* in the **KNECEXAM** folder. (1 mark)

(e) Print out later the drawing. (1 mark)

easytvvet.com

TASK 2

Technical Systems Ltd of P.O. Box 30780-00200, Nairobi, provides telecommunication services to diverse clients in Kenya. Record the following financial details and transactions of the company for the year starting 1st July 2020 using an accounting program.

Balances as at 1st July 2020	Ksh
Premises	42,502,000
Telecommunication equipment	800,206,000
Motor vehicles	76,200,000
Fixtures	100,116,000
Bank (GTI Bank)	-502,300,000
Cash	81,000,500
Creditors: Huwezi Technologies Ltd.	121,900,000
Microwave & Frequencies Ltd.	52,800,000
Debtors: Fibre Technologies Ltd.	7,110,000
Kweli Telecom Ltd.	3,052,200

The following transactions took place during the month of July 2020.

- July 1 Bought telecommunication equipment worth Ksh. 350,000,000 from Huwezi Technologies Ltd on credit.
- July 4 Paid salary advances Ksh. 2,185,000 by cash.
- July 8 Provided data services to Kawi Estates Ltd. worth Ksh 4,084,000 on credit.
- July 9 Telecom Technics Ltd provided telecommunication equipment maintenance services on credit worth Ksh 4,020, 000.
- July 14 Invoiced Dibi Financial services Ltd for voice calls service Ksh 3,900,000.
- July 21 Cash sales for the month:
 - Voice calls services Ksh 80,900,000
 - SMS services Ksh 20,300,000
 - Data Services Ksh 45,250,000
- July 21 Expenses paid by cash:
 - Salaries Ksh 48,500,000
 - Telephone Ksh 8,400,000
 - Telecom Equipment maintenance Ksh 20,240,000
- July 24 Received cheque of Ksh 6,000,000 from Fibre Technologies Ltd.
- July 25 Invoiced Kweli Telecom Ltd Ksh 3,000,000 for voice calls.
- July 26 Received invoice from Microwave & Frequencies Ltd Ksh 20,600,000 for telecom receivers.
- July 28 Acquired three 5G transmitters from Huwezi Technologies Ltd each worth Ksh 265,000,000 on credit.
- July 29 Paid Huwezi Technologies Ltd. Ksh. 94,800,000 and Microwave & Frequencies Ltd Ksh52,800,000 by cheque.
- July 31 Expenses paid by cheque:
 - Rent for Premises Ksh 6,405,800
 - Power and fuel Ksh 4,302,000

Generate and print each of the following reports:

- (a) Opening Balance sheet; (6 marks)
- (b) Cash flow statement for July 2020; (6 marks)
- (c) Trial balance as at 31st July 2020. (8 marks)

THIS IS THE LAST PRINTED PAGE.

easytvvet.com