

Name: \_\_\_\_\_

Index No. \_\_\_\_\_

2920/202B

COMPUTER APPLICATIONS II (PRACTICAL)

Paper 2

July 2015

Time: 1 hour

Candidate's Signature \_\_\_\_\_

Date: \_\_\_\_\_



THE KENYA NATIONAL EXAMINATIONS COUNCIL

DIPLOMA IN INFORMATION COMMUNICATION TECHNOLOGY

MODULE II

COMPUTER APPLICATIONS II (PRACTICAL)

Paper 2

1 hour

Edunotes.co.ke

**INSTRUCTIONS TO CANDIDATES**

*Write your name and index number in the spaces provided above.*

*Sign and write the date of examination in the spaces provided above.*

*You have ten minutes to read through the instructions and questions before starting the examination.*

*Any problem with the computer should be reported to the invigilator immediately.*

*Direct any question(s) to the invigilator only. Conversing with fellow students may lead to disqualification.*

*Write your name and index number on the Rewritable CD.*

*Type your name as a header on each sheet of paper used.*

*This paper consists of **TWO** tasks. Perform **ALL** the tasks.*

*Each task carries **20** marks.*

*Read the instructions of each task carefully.*

*Print on **one** side of the paper(s) only and use a fresh sheet of paper for each task.*

*Hand over your **printouts** and the **Rewritable CD** to the invigilator at the end of the examination.*

*Candidates should answer the questions in English.*

**This paper consists of 5 printed pages.**

**Candidates should check the question paper to ascertain that all the pages are printed as indicated and that no questions are missing.**

### TASK 1

- (a) Open a CAD program and set the default units to be in millimetres. (½ mark)
- (b) Insert **two** layers each with the following properties:
- (i) A layer labelled *drawing* with the line weight set to 0.7 mm on which to draw a block. (½ mark)
  - (ii) A layer labelled *dimension* with the line weight 0.18 mm on which to insert the dimensions. (½ mark)
  - (ii) A layer labelled *hidden* with the line weight 0.5 mm on which to draw the hidden lines. (½ mark)
- (c) (i) Figure 1 shows the isometric view of a block. Draw the front elevation, side elevation and plan elevation of the block in third angle projection. (13 marks)

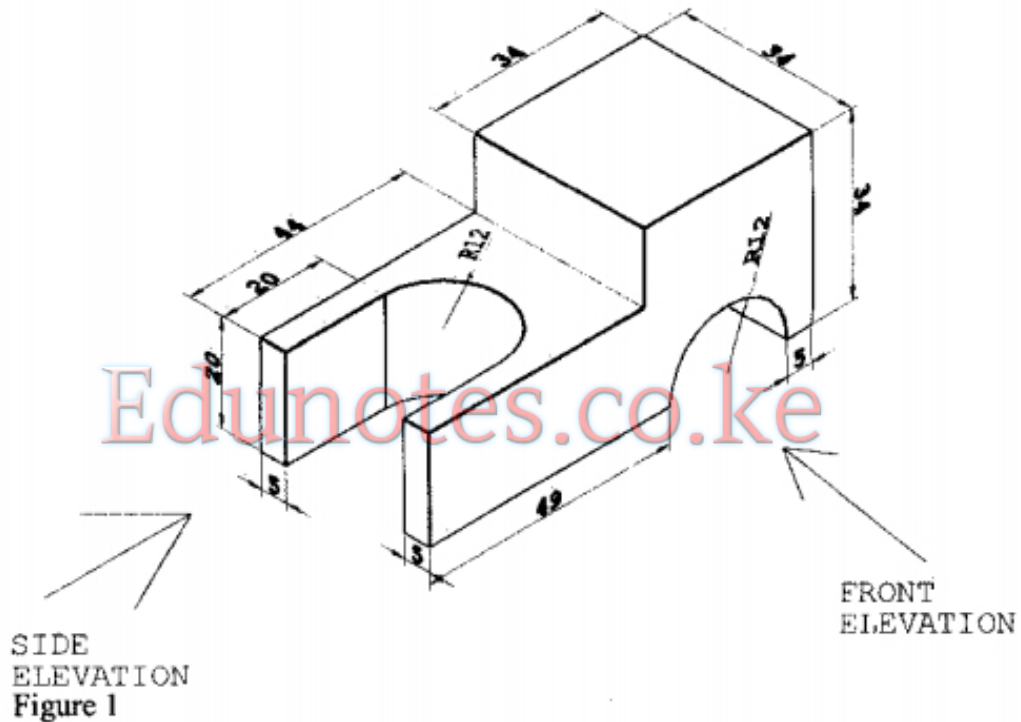

- (ii) Fully dimension the drawing on the paper space. (3½ marks)
- (d) Save the drawing as *threeviews* in the **KNECEXAM** folder to print out later. (1½ marks)

## TASK 2

Karibu Kwetu Caterers of P.O. Box 26241-00200, Nairobi provides catering and restaurant services. Using an accounting program, record the company's financial details and transaction for the month of June 2015. The following are the financial details and transactions for the year starting 1<sup>st</sup> June 2015.

### Balances as at 1<sup>st</sup> June 2015

|                            | <b>Ksh</b>   |
|----------------------------|--------------|
| Motor Vehicle              | 1,200,000    |
| Premises                   | 2,500,000    |
| Fixtures and Fittings      | 439,100      |
| Bank (HOPE)                | 146,000 (cr) |
| Cash                       | 32,820       |
| Debtors                    |              |
| Ripa Motors                | 446,000      |
| Quality Plastic Industries | 308,200      |
| Creditors                  |              |
| Kiambi Farmers             | 225,000      |
| Gila Dairies               | 165,000      |
| Kauli Suppliers            | 206,200      |

The following financial transactions took place during the month of June 2015.

### Weekly Cash Sales

|         |   |
|---------|---|
| June 8  | Tea and Snacks for Ksh 154,020 paid by cash.<br>Lunches worth Ksh 122,000 paid by cash.   |
| June 15 | Tea and Snacks for Ksh 106,250 paid by cash.<br>Lunches worth Ksh 115,230 paid by cheque. |
| June 22 | Tea and Snacks for Ksh 104,220 paid by cash.<br>Lunches worth Ksh 102,080 paid by cash.   |
| June 29 | Tea and Snacks for Ksh 104,390 paid by cash.<br>Lunches worth Ksh 92,010 paid by cheque.  |

### Cash Purchases

|         |   |
|---------|---|
| June 1  | Kitchen supplies 23,000, beverages Ksh 48,000 paid by cash.   |
| June 8  | Kitchen supplies 21,200, beverages Ksh 40,340 paid by cash.   |
| June 15 | Kitchen supplies 20,020, beverages Ksh 39,310 paid by cheque. |
| June 22 | Kitchen supplies 19,050, beverages Ksh 38,950 paid by cash.   |

### Invoices Issued

|         |  |
|---------|--|
| June 3  | Mirandi Contractors Ksh 1,500,000 for catering services for the month of May 2015. |
| June 15 | Quality Plastic Industries Ksh 230,000 for catering services.                      |
| June 30 | Ripa Motors Ksh 308,900 for catering services.                                     |
| June 30 | Quality Plastic Industries Ksh 230,000 for catering services.                      |

### Invoices Received

|         |  |
|---------|--|
| June 20 | Kiambi Farmers Ksh 300,000 for kitchen supplies. |
| June 30 | Gila Dairies for milk supplies Ksh 150,000.      |
| June 30 | Kweli Distributors for beverages Ksh 127,280.    |

**Cheque Received**

|         |   |
|---------|---|
| June 13 | Quality Plastic Industries Ksh 430,000. |
| June 21 | Ripa Motors Ksh 400,000.                |
| June 28 | Mirandi Contractors Ksh 700,000.        |

**Cheque Payments**

|         |                              |
|---------|------------------------------|
| June 15 | Kiambi Farmers Ksh 200,000 . |
| June 20 | Gila Dairies Ksh 150,000.    |
| June 30 | Kauli Suppliers Ksh 206,200. |
| June 30 | Salaries Ksh368,000.         |

**Cash Payments**

|         |   |
|---------|---|
| June 4  | Water Ksh 12,000, Electricity Ksh 34,000, Gas Ksh 48,000.   |
| June 28 | Staff health check rates paid to Nairobi County Ksh 33,000. |

Generate each of the following to print out later:

- (a) Transaction summary report for the month. (9 marks)
- (b) Income statement for the month. (5 marks)
- (c) Statement of Financial Position as at 30<sup>th</sup> June 2015. (6 marks)

Edunotes.co.ke