

# MATHEMATICS TOPICAL QUESTIONS

## L.C.M

1. A piece of land is to be divided into 20 acres or 24 acres or 28 acres for farming and leave 7 acres for grazing. Determine the smallest size of such land.
2. When a certain number  $x$  is divided by 30, 45 or 54, there is always a remainder of 21. Find the least value of the number  $x$
3. A number  $m$  is such that when it is divided by 30, 36, and 45, the remainder is always 7. Find the smallest possible value of  $m$
4. Find the L.C.M of  $x^2 + x$ ,  $x^2 - 1$  and  $x^2 - x$

## 1. Integers

1.  $3x - 1 > -4$   
 $2x + 1 \leq 7$
2. Find the value of  $x$   
 $2^{(x-3)} \times 8^{(x+2)} = 128$

## 2. Decimals

1. Without using mathematical tables or calculators, evaluate: (3 mks)

$$\frac{0.0168 \times 2.46 \times 7}{5.74 \times 0.112}$$

2. A two-digit number is such that the sum of the ones digit and the tens digit is 10. If the digits are reversed, the number formed exceeds the original number by 54. Find the number (3 mks)

1. Use a calculator to find;  
(a)  $8754.3 \times 53.84$   
(b)  $0.8341 + 8.72$

Hence find;  $\sqrt[3]{\frac{8754.3 \times 53.84}{0.8341 + 8.72}}$

2. Express the recurring decimal below to a fraction 5.72 and leaving your answer in the form  $\frac{a}{b}$  where  $a$  and  $b$  are whole numbers
3. Evaluate:-  $0.38 \times 0.23 \times 2.7$  without using tables or a calculator

4. Without using mathematical tables or calculator, evaluate:

$$\frac{0.084 \times 1.32 \times 3.5}{2.87 \times 0.056}$$

Leaving the answer as a fraction in its simplest form.

5. Find without using a calculator, the value of :

$$\frac{12\sqrt{0.0625} - 12.4 \div 0.4 \times 3}{\frac{1}{8} \text{ of } 2.56 + 8.68}$$

### 3. Squares and square roots

- Use tables to find;  
a) i)  $4.978^2$   
ii) The reciprocal of 31.65  
b) Hence evaluate to 4.S.F the value of  $4.978^2 - 1/31.65$
- Use tables of squares, square roots and reciprocals to evaluate correct to 4 s.f  
$$\sqrt[3]{0.0136} - \frac{2}{(3.72)^2}$$
- Without using mathematical tables or calculator, evaluate:  $\frac{153 \times 1.8}{\sqrt{0.68 \times 0.32}}$  giving your answer in standard form

### 4. Algebraic expressions

- Five year ago, a mother's age was four times that of her daughter. In four years to come, she will be  $2\frac{1}{2}$  times the age of her daughter. Calculate the sum of their present ages
- Mutua bought 160 trays of 8 eggs each at shs.150 per tray. On transportation 12 eggs broke. He later discovered that 20 eggs were rotten. If he sold the rest at shs.180 per tray, how much profit did he make?
- Simplify;  
(a)  $6a - 2b + 7a - 4b + 2$   
(b)  $\frac{2x-2}{2x} - \frac{3x+2}{4x}$
- Simplify  $\frac{6x^2y^2 + 13xy - 5}{3x^2y^2 - 13xy + 4}$
- Given that  $x + y = 8$  and  $x^2 + y^2 = 24$   
Find;  
(a) the value of  $x^2 + 2xy + y^2$   
(b) Find the value of  $2xy$   
(c)  $x^2 - 2xy + y^2$   
(d)  $x - y$   
(e) Value of  $x$  and  $y$
- Simplify the expression.  
$$\frac{6x^2 + 35x - 6}{2x^2 - 72}$$
- Simplify the expression  
$$\frac{2}{3}(3x-2) - \frac{3}{4}(2x-2)$$
- Simplify by factorizing completely:  
$$\frac{4y^2 - x^2}{2x^2 - yx - 6y^2}$$
- Simplify as far as possible.  
$$\frac{3}{x-y} - \frac{1}{x+y}$$
- By calculation, find the coordinates of the intersection of the graphs  $y = x^2 + 2x - 5$

and  $y = 3x + 1$

11. Simplify:

(a)  $\frac{y^2 + 2y}{y^3 - y^2 - 6y} = \frac{1}{4}$

(b) hence solve:  $\frac{y^2 + 2y}{y^3 - y^2 - 6y} = \frac{1}{4}$

12. A rectangular field measures 63.9m by 104.6metres find the minimum number of poles to be erected for fencing if they are to be at most 2.4meters apart.

13. Factorize completely the expression  $75x^2 - 27y^2$

14. Every time an insect jumps forward the distance covered is half of the previous jump.

If the insect initially jumped 8.4cm, calculate

(i) To the nearest two decimal places distance of the sixth jump

(ii) The total distance covered after the sixth jump

15. Simplify  $\frac{P^3 - Pq^2 + P^2q - q^3}{P^2 + 2pq + q^2}$

16. Simplify the expression:  $\frac{9x^2 - 4y^2}{12x^2 + yx - 6y^2}$

17. Given that  $(x-3)(Ax^2+bx+c) = x^3-7x-6$ , find the value of A, B and C

18. a) solve for y in  $8x(2^2)^y = 6x2^y - 1$

b) Simplify completely  $\frac{2x^2-98}{3x^2-16x-35} \div \frac{x+7}{3x+5}$

19. Simplify the expression.:

$$\frac{4x^2 - y^2}{2x^2 - 7xy + 3y^2}$$

20. Simplify  $\frac{P^2 - 2Pq + q^2}{P^3 - Pq^2 + P^2q - q^3}$

21. The sum of two numbers is 15. The difference between five times the first number and three times the second number is 19. Find the two numbers

22. Simplify the following expressions by reducing it to a single fraction

$$\frac{2x-5}{4} - \frac{1-x}{3} - \frac{x-4}{2}$$

23. Simplify the expression:  $\frac{-3a^2 + 4ab + b^2}{4a^2 + 3ab - b^2}$

### 5. Rates, Ratio and percentages

1. If 5 men can erect 2 cottages in 21days, how many more men, working at the same rate will be needed to erect 2 cottages in the same period?

2. The length and width of a rectangular paper were measured to the nearest centimeter

and found to be 18cm and 12cm respectively. Find the percentage error in its perimeter in 6 hrs.

3. a) Two pipes **A** and **B** can fill a tank in 3hrs and 4 hrs respectively. Pipe **C** can empty the full tank
  - i) How long would it take pipes **A** and **B** to fill the tank if pipe **C** is closed?
  - ii) Starting with an empty tank, how long would it take to fill the tank with all pipes running?b) The high quality Kencoffee is a mixture of pure Arabica coffee and pure Robusta coffee in the ratio 1 : 3 by mass. Pure Arabica coffee costs shs. 180 per kg and pure Robusta coffee costs sh 120 per kg. Calculate the percentage profit when the coffee is sold at sh 162 per kg.
4. A number of nurses working at Sotik Health Centre decided to raise shs.144,000 to buy a plot of land. Each person was to contribute the same amount. Before the contributions were collected five of the nurses retired. This meant that the remaining contributors had to pay more to meet the target.
  - (a) If there were  $n$  nurses originally, find the expression of the increase in contribution per person
  - (b) If the increase in the contribution per person was shs.2,400, find the number of nurses originally at the health centre
  - (c) How much would each person have contributed to nearest shilling if the 5 people had not retired
  - (d) Calculate the percentage increase in the contribution per person because of the retirement
5. 3 taps **X**, **Y** and **Z** can fill a tank in 40 hours, 15 hours and 20 hours respectively. The three taps are turned on at 8.00a.m when the tank is empty for five hours then **Z** is turned off. After two hours tap **Y** is turned off. Work out ;-
  - (a) The proportion of water in the tank after seven hours
  - (b) The proportion of water in the tank after seven hours
  - (c) The time the tank will be completely full
6. Jane and Philip working together can do a piece of work in 6 days. Jane working alone takes 5 days longer than Philip. How many days does it take Philip to do the work alone?
7. Sixteen men working 9 hours a day can complete a piece of work in 14 days. How many more men working 7 hours a day would complete the same job in 12 days?
8. A group of people planned to contribute equally towards buying land at a price of shs.180000. However 3 members of the group withdrew from the project. As a result, each of the remaining members were to contribute kshs.3000 more.
  - (a) find the original number of members in the group
  - (b) How much would each person have contributed if the 3 people had not withdrew
  - (c) Calculate the percentage increase in the contribution per person caused by the withdrawal
9. Kori and Mue decided to start a business. Korir contributed shs.40,000 and Mue shs.64000. The two men agreed that in any year, 15% of the profit shall be divided equally between them and 20% of the profit will be used to meet the cost of running the business the following year. They also agreed to share the rest of the profit in the ratio of their contributions. The profit made after the first year was shs.43200.
  - a) How much did they set aside towards the cost of running the business for the second year?\*
  - b) How much did Mue receive at the end of the first year?
  - (c) Korir bought cows with his share of the profit. If each cow cost shs.1800, how many cows did he buy?
10. Given the ratio  $x : y = 2:3$ , find the ratio  $(7x - 3y) : (2x + 3y)$
11. Abdul bought five bulls and thirty goats at an auction spending a total of Kshs.117000.

His friend Ali bought four bulls and twenty five goats at the same auction and spent Kshs.22,250 less.

(a) Find the cost of each animal at the auction

(b)

Abdul later sold all his animals at a profit of 40% per bull and 30% per goat. Ali sold all his animals at a profit of 50% per bull and 40% per goat. Determine who made more profit and by how much?

12. The cost of providing a commodity consists of transport, labour and raw material in the ratio 8:4:12 respectively. If the transport cost increases by 12% labour cost 18% and raw materials by 40%, find the percentage increase of producing the new commodity
13. A mother is now  $2\frac{1}{2}$  times as old as her daughter Mary; four years ago the ratio of their ages was 3:1. Find the present age of the mother
14. Sixteen men working at the rate of 9hrs a day can complete a piece of work in 14 days. How many more men working at the rate of 7 hours a day would complete the same job in 12 days
15. Two business partners, Kago and Beatrice contributed 90, 000/= and 120,000/= in order to start a business. They agreed that 25% of the profit made after end of the year will be put back into the business. They also estimated that 40% of the profit will cover salaries and other expenses for the year. The remainder would be shared between the partners in the ratio of their contributions. At the end of the first year the business realized a gross profit of shs.181,300.
  - a) Calculate how much each received after end of the year.
  - b) At the end of 2<sup>nd</sup> year the business realized the same gross profit as the previous year and the partners decided to dissolve the business and share everything . Determine how much money each received.
16. A number is such that the product of its digits is 24. When the digits are reversed, the number so formed exceeds the original number by 27. Find the number
17. The radius of a cylinder is increased by 30% while its height is decreased by 20%. Find the percentage change in the volume of the cylinder
18. Tap **A** fills a tank in 6 hours, tap **B** fills it in 8 hours and tap **C** empties it in 10 hours. Starting with an empty tank and all the three taps are opened at the same time, how long will it take to fill the tank?
19. Sixteen men working 9 hours a day can complete a piece of work in 14 days. How many more men working 7 hours a day would complete the same job in 12 days?
20. Three businessmen Langat, Korir and Koech contributed shs.160,000, Shs.200,000 and shs.240,000 respectively and started a business. They agreed that 30% of the profit each year will go to expenses, 15% of the remainder would go back to the business. The rest of the profit would be shared in the ratio of their contribution. At the end of the first year, the business realized a profit of kshs.60,000. Calculate how much;
  - (a) (i) Langat received
  - (ii) Korir received
  - (iii) Koech received
  - (b) Express what Korir received as a percentage of the total profit

21. The price of a book is increased by 25%.  
 (a) In what ratio has the price increased?  
 (b) What is the new price if the book was shs.400 before the change?
22. (a) A chemist added 120 liters of a solution A containing 25% alcohol to 180 liters of solution B containing 20% alcohol. What percentage of the resulting solution is alcohol?  
 (b) He removed  $X$  liters of resulting mixture and added an equal amount of pure alcohol to the resulting mixture. If the new mixture contains 22% of the alcohol, find the value of  $X$
23. The length and width of a rectangular paper were measured to the nearest centimeter and found to be 18cm and 12cm respectively. Find the percentage error in its perimeter
24. Given that  $a:b = 1:2$  and  $b:c = 3:4$ . Find  $a:b:c$

## 6. length

- 1 Simplify, by factorization:  

$$\frac{15x^2 + xy - 6y^2}{5x^2 - 8xy + 3y^2}$$
2. Given the matrices  $M = \begin{pmatrix} 3 & 0 \\ -1 & 4 \end{pmatrix}$ ,  $R = \begin{pmatrix} -1 & 2 \\ 0 & 0 \end{pmatrix}$  and  $N = \frac{2}{3} \begin{pmatrix} 1 & 1 \\ 2 & 4 \end{pmatrix}$ . Find the value of value of  $3n + \frac{1}{2}(R-M)$

## 7. Area

1. Calculate the area of the shaded region below, given that AC is an arc of a circle centre B.  $AB=BC=14\text{cm}$   
 $CD=8\text{cm}$  and angle  $ABD = 75^\circ$  (4 mks)

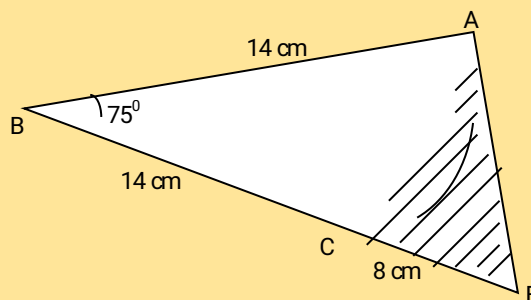

1. A student took the measurements of his classroom and gave the width as 7m and the length as 9m. If there is an error of 2% in each measurement, determine the greatest value of  $x+y$  if  $x$  and  $y$  are the width and length of the classroom respectively. Give your answer to 4 decimal places.
2. The floor of a room is in the shape of a rectangle 10.5 m long by 6 m wide. Square tiles of length 30 cm are to be fitted onto the floor.  
 (a) Calculate the number of tiles needed for the floor.  
 (b) A dealer wishes to buy enough tiles for fifteen such rooms. The tiles are packed in cartons each containing 20 tiles. The cost of each carton is Kshs. 800. Calculate  
 (i) the total cost of the tiles.

(ii) If in addition, the dealer spends Kshs. 2,000 and Kshs. 600 on transport and subsistence respectively, at what price should he sell each carton in order to make a profit of 12.5% (Give your answer to the nearest Kshs.)

3. The figure below is a circle of radius 5cm. Points **A**, **B** and **C** are the vertices of the triangle ABC in which  $\angle ABC = 60^\circ$  and  $\angle ACB = 50^\circ$  which is in the circle. Calculate the area of  $\triangle ABC$

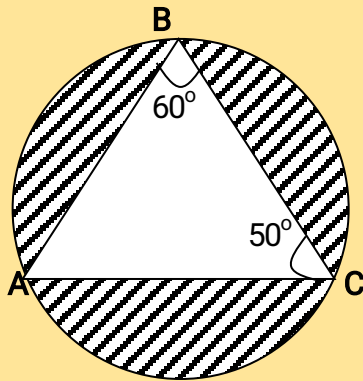

4. Mr. Wanyama has a plot that is in a triangular form. The plot measures 170m, 190m and 210m, but the altitudes of the plot as well as the angles are not known. Find the area of the plot in hectares
5. Three sirens wail at intervals of thirty minutes, fifty minutes and thirty five minutes. If they wail together at 7.18a.m on Monday, what time and day will they next wail together?
6. A farmer decides to put two-thirds of his farm under crops. Of this, he put a quarter under maize and four-fifths of the remainder under beans. The rest is planted with carrots. If 0.9acres are under carrots, find the total area of the farm
7. Find the area of the circle sector.

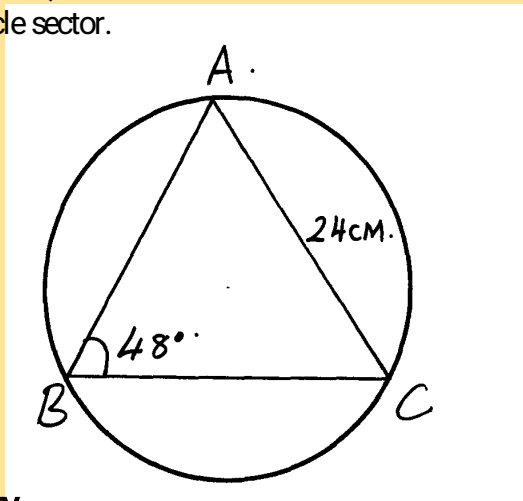

## 8. Volume and capacity

1. A village water tank is in the form of a frustum of a cone of height 3.2m. The top and bottom radii are 18m and 24m respectively
- (a) Calculate:
- The surface area of the tank excluding the bottom
  - The capacity of the water tank
- (b) 15 families each having 15 members use the water tank and each person uses 65 litres of water daily. How long will it take for the full tank to be emptied
2. The diagram below shows a bucket with a top diameter 30cm and bottom diameter 20cm. The height of the bucket is 28cm
- (a) Calculate the capacity of the bucket in litres



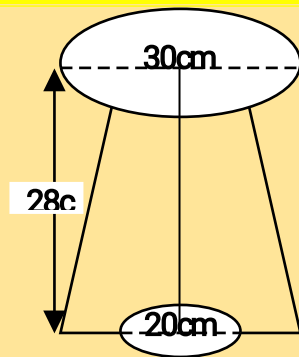

(b) Find the area of the metal sheet required to make 100 such buckets taking 10% extra for overlapping and wastage

3. A rectangular water tank measures 2.6m by 4.8m at the base and has water to a height of 3.2m. Find the volume of water in litres that is in the tank

4. The figure alongside shows a cone from which a frustum is made. A plane parallel to the base cuts the cone two thirds way up the vertical height of the cone to form frustum **ABCD**. The top surface radius of the frustum is labeled  $r$  and the bottom radius is  $R$

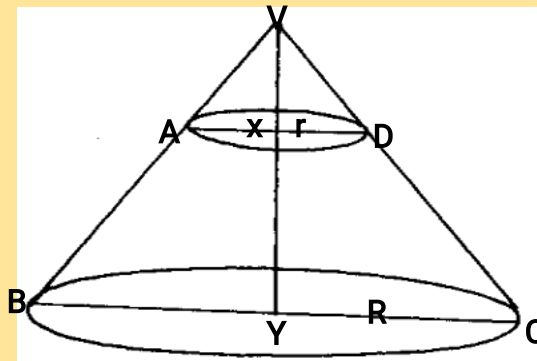

a) Find the ratio  $r:R$

b) Given that  $r = 7\text{cm}$ , find  $R$

c) If the height  $Y$  of the original cone is 45cm, calculate to the nearest whole number the volume of the frustum

d) The frustum represents a bucket which is used to fill a rectangular tank measuring 1.5m long, 1.2m wide and 80cm high with water. How many full buckets of water are required to fill the tank

5. Three litres of water (density  $1\text{g/cm}^3$ ) is added to twelve litres of alcohol (density  $0.8\text{g/cm}^3$ ). What is the density of the mixture?

6. A rectangular tank whose internal dimensions are 2.2m by 1.4m by 1.7m is three fifth full of milk.

(a) Calculate the volume of milk in litres

(b) The milk is packed in small packets in the shape of a right pyramid with an equilateral base triangle of sides 10cm. The vertical height of each packet is 13.6cm. Full packets obtained are sold at shs.30 per packet. Calculate:

(i) The volume in  $\text{cm}^3$  of each packet to the nearest whole number

(ii) The number of full packets of milk

(iii) The amount of money realized from the sale of milk

7. An 890kg culvert is made of a hollow cylindrical material with outer radius of 76cm and an inner radius of 64cm. It crosses a road of width 3m, determine the density of the material used in its construction in  $\text{Kg/m}^3$  correct to 1 decimal place.



## 9. Mass, weight and density

1. A piece of metal has a volume of  $20 \text{ cm}^3$  and a mass of 300g. Calculate the density of the metal in  $\text{kg/m}^3$ .
2. 2.5 litres of water density  $1\text{g/cm}^3$  is added to 8 litres of alcohol density  $0.8\text{g/cm}^3$ . Calculate the density of the mixture

## 10. Time

1. A van travelled from Kitale to Kisumu a distance of 160km. The average speed of the van for the first 100km was 40km/h and the remaining part of the journey its average speed was 30km/h. Calculate the average speed for the whole journey. (3 mks)
1. A watch which loses a half-minute every hour was set to read the correct time at 0545h on Monday. Determine the time, in the 12 hour system, the watch will show on the following Friday at 1945h.
2. A watch which loses a half-minute every hour was set to read the correct time at 0445h on Monday. Determine the time in 12-hour system, the watch will show on the following Friday at 1845h
3. The timetable below shows the departure and arrival time for a bus plying between two towns **M** and **R**, 300km apart

Town	Arrival	Departure
M		0830h
N	1000h	1020h
P	1310h	1340h
Q	1510h	1520h
R	1600h	

- (a) How long does the bus take to travel from town **M** to **R**?
- (b) What is the average speed for the whole journey?

# 11. Linear

1. Determine the inequalities that represent and satisfies the unshaded region (3 mks)

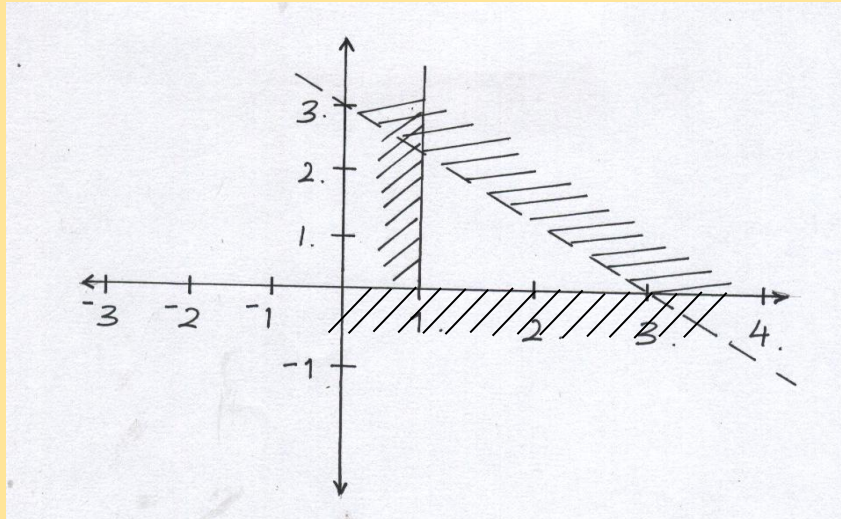

1. The diagram below shows the graphs of  $y \geq \frac{3}{10}x - \frac{3}{2}$ ,  $5x + 6y = 3$  and  $x = 2$

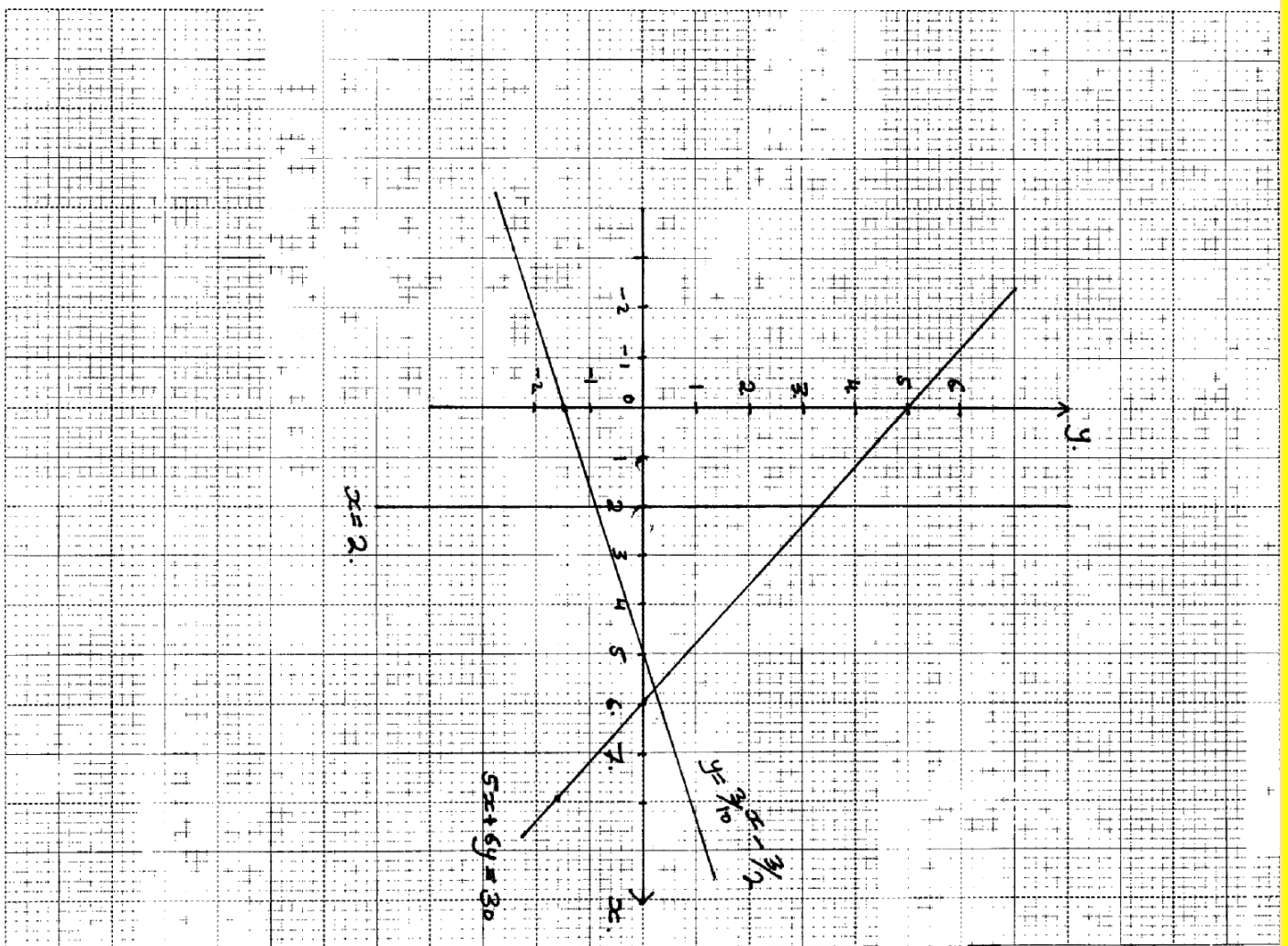

By shading the unwanted region, determine and label the region **R** that satisfies the three inequalities;  $y \geq \frac{3}{10}x - \frac{3}{2}$ ,  $5x + 6y \geq 30$  and  $x \geq 2$

2. The cost of 7 shirts and 3 pairs of trousers is shs. 2950 while that of 5 pairs of trousers and 3 shirts

is less by 200. How much will Dan pay for 2 shirts and 2 pairs of trousers?

3. Mr. Wafula went to the supermarket and bought two biros and five pencils at sh.120. Whereas three biros and two pencils cost him sh.114. Find the cost of each biros and pencils
4. A father is twice as old as his son now. Ten years ago, the ratio of their ages was 5:2. Find their present ages
5. List the integral values of  $x$  which satisfy the inequalities below:-  
 $2x + 21 > 15 - 2x \geq x + 6$
6. Find the equation of a line which passes through  $(-1, -4)$  and is perpendicular to the line:-  
 $y + 2x - 4 = 0$
7. John bought two shirts and three pairs of trousers at Kshs. 1750. If he had bought three shirts and two pairs of trousers, he would have saved Kshs. 250. Find the cost of a shirt and a trouser.
8. Express the recurring decimal 3.81 as an improper fraction and hence as a mixed number
9. Karani bought 4 pencils and 6 biro pens for shs.66 and Mary bought 2 pencils and 5 biro pens for shs.51
  - (a) Find the price of each item
  - (b) Ondieki spent shs.228 to buy the same type of pencils and biro pens. If the number of biro pens he bought were 4 more than the number of pencils, find the number of pencils he bought
10. Two consecutive odd numbers are such that the difference of twice the larger number and twice the smaller number is 21. Find the product of the numbers
11. The size of an interior angle of a regular polygon is  $3x^\circ$  while its exterior angle is  $(x-20)^\circ$ . Find the number of sides of the polygon
12. Five shirts and four pairs of trousers cost a total of shs.6160. Three similar shirts and a pair of trouser cost shs.2800. Find the cost of four shirts and two pairs of trousers
13. Two pairs of trousers and three shirts costs a total of Shs.390. Five such pairs of trousers and two shirts cost a total of Shs.810. Find the price of a pair of trouser and a shirt

## 12. Equations

1. Solve the simultaneous equation (3 mks)

$$2x - y = 3$$

$$x^2 - xy = -4$$

1. A Kenyan businessman US\$100 to a company in the United States of America. The Kenyan can either pay through his account in Kenya or through his account in the United Kingdom. Which method is cheaper and by how much? Give your answer in Kenya shillings given that;  
1 US dollar = 76.84 Kenya shillings  
1 Sterling Pound = 1.53 US dollars  
1 Sterling pound = 115.70 Kenya shillings
2. Foreign exchange on 27/5/2010 was given as follows.

Currency	Buying (Kshs)	Selling (Kshs)
1 Euro	84.15	84.26
1 Sterling pound	118.35	121.47

A tourist came to Kenya from London with 6000 Euros which he converted to Kenya shillings at a bank. While in Kenya he spent a total of Kshs.300,000 then converted the balance into sterling pounds at the Same bank. Calculate the amount in sterling pounds he received.

3. A Kenyan football fan visited South Africa from Kenya. He changed his currency from Kenya shillings to South African rand. The exchange rates in Kenya were as per the table below:-

Buying	Selling
9.9399	10.0166

He has a total of shs.2, 8000,265 and must spend 13 days. During his stay, he spent 8900 Rands on food and accommodation, 97,000 Rands on a return air ticket and 53689 Rands on entertainment. On his return, he converted the remaining amount into Kshs. How much did he receive to the nearest cents?

4. A French tourist changes 3000 Francs into Kenyan shillings at 1 Franc = Kshs.1.89. He spends shs.4695, then exchanges the remaining shillings back into Francs at 1 Franc =1.95. How many Francs does he receive?
5. Hamisi arrived in Nairobi from USA with 40 travelers cheques each with 75 US dollars. How much does she receive in Kshs from the bank on a day when 1 US dollar was equivalent to Kshs 81.40 and the bank charges commission at the rate of Kshs.100 per travelers cheque

6. A Kenya bank buys and sells foreign currencies as shown below

	Buying in Kshs.	Selling in Kshs.
1 Hong Kong dollar	9.74	9.77
1 South African rand	12.03	12.11

A tourist arrived in Kenya with 105,000 Hong Kong dollars and changed the amount to Kenya shillings. While in Kenya, she spent Shs.403,879 and changed the balance to South African rand before leaving for South Africa. Calculate the amount, in South African rand that she received

7. A Japanese tourist entered Kenya with Kshs.500,000 Japanese Yen which he converted to Kenya currency. While in Kenya, he spend Kshs.16200 in all. He then converted all the remaining money into Euros before leaving for Italy. If he carried out all his transactions at the Stanbic bank using rates shown below, calculate to the nearest Euro, how much money he left Kenya with. *(Do not use mathematical tables for this question)*

	Selling (Kshs)	Buying Kshs
100 Japanese Yen	66.35	66.05
1 Euro	78.15	77.85

8. Do not use mathematical tables in this question. Equity bank buys and sells foreign currencies as shown:-

	Buying (Kshs.)	Selling Kshs.
1 US dollar	77.43	78.10
1 South African Rand	9.03	9.51

A tourist arrived in Kenya with 5,600 US dollars and changed the whole amount to Kenya shillings while in Kenya he spend shs.201,367 and changed the balance to South African rand

before leaving to S. Africa . Calculate the amount in S. African rand that she received

9. A tourist arriving from Britain had UK £ 9000. He converted the pounds to Kenyan shillings at a commission of 5%. While in Kenya he spent  $\frac{3}{4}$  of his money. He exchanged the remaining to US dollars with no commission. Calculate to the nearest US dollars the amount using the exchange rate below.

Currency	Buying Kshs.	Selling Kshs.
1 US Dollar	63.00	63.20
1 UK Dollar	125.30	125.95

10. A company was to import goods worth Kshs.100,000 from U.K and changed the money to Sterling pounds. The company later realized that it was cheaper to import the same goods from U.S.A and changed the sterling pounds to dollar. Unfortunately the transaction failed and the money was converted to Kenya shillings. How much money did the company end-up with, given that;
- 1 US dollar = Kshs.78  
1 Sterling pound = Kshs.120  
1 Sterling pound = 1.79 U.S dollar
11. A tourist arrives in Kenya from England with S.£ 50,000 and uses the money to buy Kenya shillings. He quickly changes his mind and sells the Kenya shillings to get back his s£. How much money in S.£ did he get? Use the table below

	buying	selling
1 Sterling pound	120.7131	120.9294

12. A Kenyan bank buys and sells foreign currencies at the exchange rates shown below:

	Buying (Kshs.)	Selling (Kshs.)
1 Euro	147.86	148.00
1 US Dollar	74.22	74.50

An American arrived in Kenya with 20000 Euros. He converted all the Euros to Kenya shillings at the bank. He spent Kshs.25100 200 while in Kenya and converted the remaining Kenya shillings into US Dollars at the bank. Find the amount in dollars that he received

13. Simplify;
- (a)  $6a - 2b + 7a - 4b + 2$
- (b)  $\frac{2x-2}{2x} - \frac{3x+2}{4x}$

### 13. Commercial arithmetic

1. Jane is a sales executive earning a salary of Ksh. 20,000 and a commission of 8% for the sales in excess of Ksh 100,000. If in January 2010 she earned a total of Ksh.48, 000 in salaries and commissions.
- a) Determine the amount of sales she made in that month (4 mks)
- b) If the total sales in the month of February and March increased by 18% and then dropped by 25% respectively. Calculate
- (i) Jane's commission in the month of February (3 mks)
- (ii) Her total earning in the month of March (3 mks)
2. Wekhomba bought a laptop in Uganda for Ush.1, 050,000. He then paid 60 US dollars as transportation charges to Kenya. On arrival in Kenya he paid duty and sales tax amounting to 55% of the cost in Uganda. He then gave it to a friend in Tanzania tax free. If the exchange rates were 1 US dollar = Ush 1016, 1Ksh = Ush 24.83 and Tsh 1 = Ksh 0.0714
- (a) Calculate the total expenses in Kenya shillings incurred by Wekhomba (3 mks)
- (b) Find the expenditure on transportation and taxes as a percentage of the total expenditure (2 mks)
- (c) What is the total value of the laptop in Tanzanian shillings (2 mks)
- (d) Find the overall increase in value of the laptop as percentage of the buying price (3 mks)

1. Find the angle  $\theta$  in degrees from the figure below

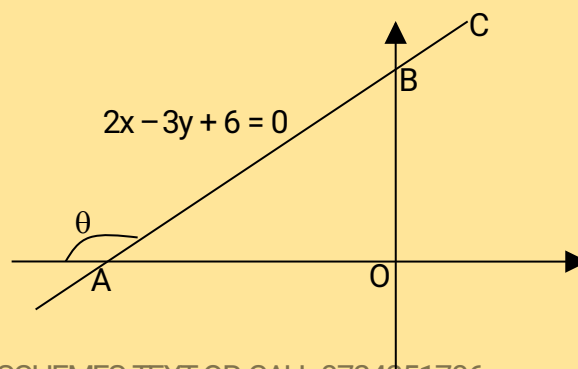

2. In the diagram below, determine the equation of the line **XY** in the form  $y = mx + c$

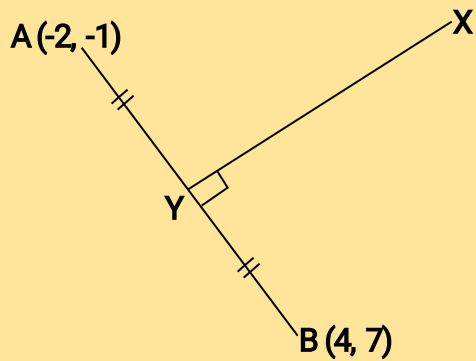

3. Find the equation of a line which passes through the point (2, 3) and is perpendicular to  $y - 3x + 1 = 0$ , giving your answer in the form  $y = mx + c$
4. T is the mid-point of line **XY** where **X** is point (1, 4) and **Y** is the point (-5, 10). Find the equation of a line,  $L_2$  which is perpendicular to line **XY** and goes through point **T**
5. (a) On the grid provided below, plot points A(2, 1) B(-4, 3) and C(2, 5)  
b) Given that the gradient of CD = -1 and CD = AD locate D and complete the quadrilateral ABCD  
c) What name is given to quadrilateral ABCD?



6. In the figure below (not drawn to scale), PQRS is a rectangle and P and Q are the points (3, 2) and (1, 4) respectively

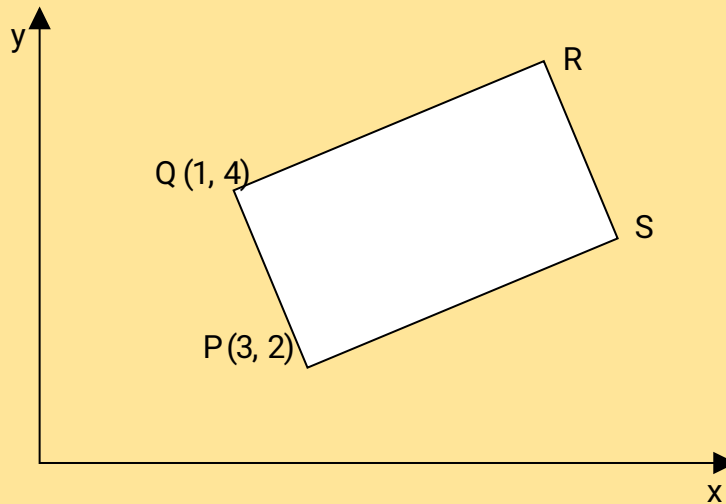

Given that the equation of the line PQ is  $y = 3x - 7$ , find:

- The equation of line QR
  - The coordinates of point R
  - The coordinates of point S
7. OABC is a trapezium such that the coordinates of O, A, B and C are (0, 0), (2, -1), (4, 3) and (0, y)
- Find the value of y
  - M is the mid-point of AB and N is the mid-point of OM. Find in column form
    - the vector **AN**
    - the vector **NC**
    - Vector **AC**
- (c) Hence show that A, N and C are collinear
8. Use ruler and a pair of compasses only in this question.
- Construct triangle ABC in which  $AB = 7$  cm,  $BC = 8$  cm and  $\angle ABC = 60^\circ$ .
  - Measure (i) side AC (ii)  $\angle ACB$
  - Construct a circle passing through the three points A, B and C. Measure the radius of the circle.
  - Construct  $\triangle PBC$  such that P is on the same side of BC as point A and  $\angle PCB = \frac{1}{2} \angle ACB$ ,  $\angle BPC = \angle BAC$  measure  $\angle PBC$ .
9. ABCD is a parallelogram with vertices A (1, 1) and C(8, 10). AB has the equation  $4x - 5y = -1$  and BC has the equation  $5x - 2y = 20$ . Determine by calculation;
- the co-ordinates of the point M where the diagonals meet
  - The co-ordinates of the vertices B and D
  - the length of AB correct to 4 significant figures
10. The table shows corresponding values of x and y for a certain curve;

x	1.0	1.2	1.4	1.6	1.8	2.0	2.3
y	6.5	6.2	5.2	4.3	4.0	2.6	2.4

Using 3 strips and mid-ordinate rule estimate the area between the curve, x-axis, the lines  $x=1$  and  $x=2.2$

## 14. Coordinates and Graphics

- The size of an interior angle of a rectangular polygon is  $6\frac{1}{2}$  times that of its exterior angle. Determine the number of sides of the polygon.
- The sum of interior angles of two regular polygons of sides  $n$  and  $n + 2$  are in the ratio 3:4. Calculate the sum of the interior angles of the polygons with  $n$  sides
- The area of a rhombus is  $60\text{cm}^2$ . Given that one of its diagonals is 15cm long. Calculate the perimeter of the rhombus.
- In the figure below AE is parallel to BD.  $BC = BD$ ,  $AB = 7.25\text{cm}$ ,  $AE = 15.25\text{cm}$  and  $ED = 5.25\text{cm}$

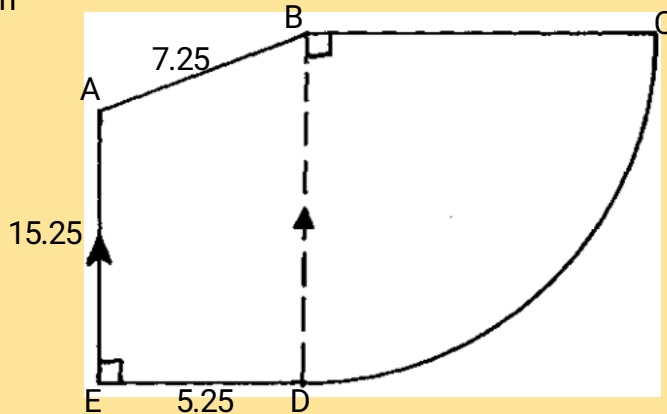

Find the perimeter of the figure .

- The figure below shows a trapezium ABCD in which side AB is perpendicular to both AD and BC. Side  $AD=17\text{cm}$ ,  $DC=10\text{cm}$

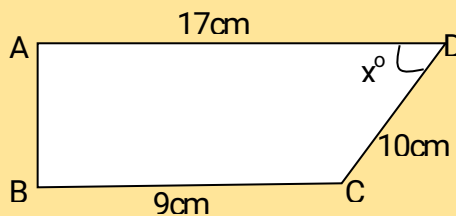

- What is the length of side AB
  - Find the value of  $\cos(90^\circ - x^\circ)$  in the form  $\frac{a}{b}$  where  $a$  and  $b$  are integers
- The size of an interior angle of a regular polygon is  $3x^\circ$  while its exterior angle is  $(x-20)^\circ$ . Find the number of sides of the polygon

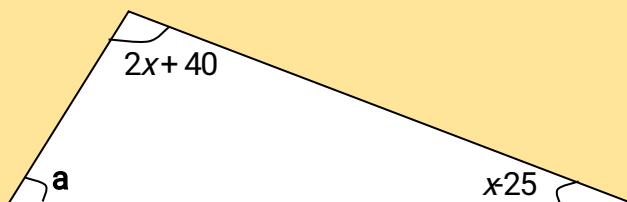

- In the figure above, angle  $a$  is half the sum of the other angles. Evaluate the triangle
- The sum of the interior angles of an  $n$ -sided polygon is  $1260^\circ$ . Find the value of  $n$  and hence deduce the polygon

9. Giving reason, find the angle marked  $n$

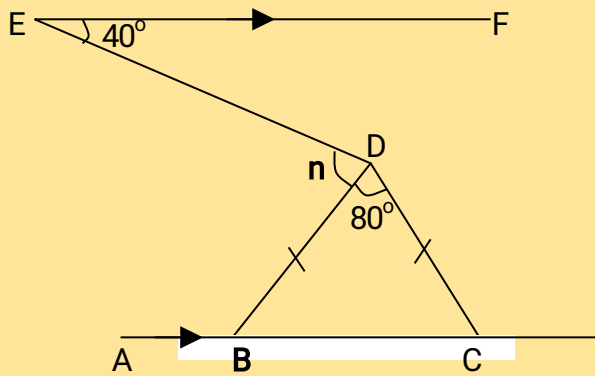

10. Solve for  $y$  in the equation  $125^{y+1} + 5^{3y} = 630$
11. The interior angle of a regular polygon is  $108^\circ$  larger than the exterior angle. How many sides has the polygon?
12. The interior angle of a regular polygon is 4 times the exterior angle. How many sides has the polygon?
13. In the figure below ABCD is a trapezium with DC parallel to AB. DC = 5cm, CB = 4cm, BD = 8cm and AB = 10cm

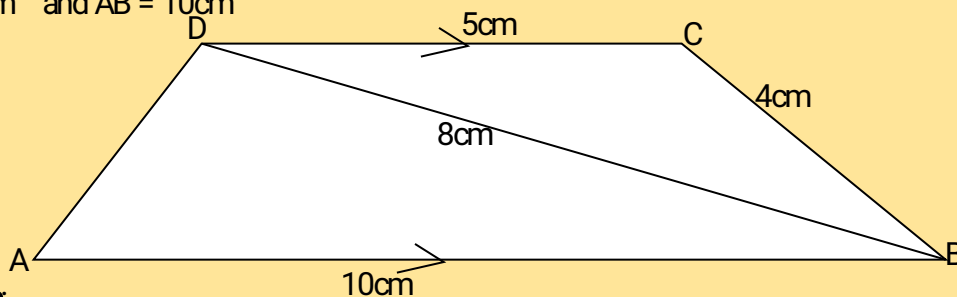

**Calculate:**

- (a) the size of angle BDC  
 (b) the area of triangle ABD

14. In the figure below, DE bisects angle BDG and AB is parallel to DE. Angle DCF =  $60^\circ$  and angle CFG =  $100^\circ$

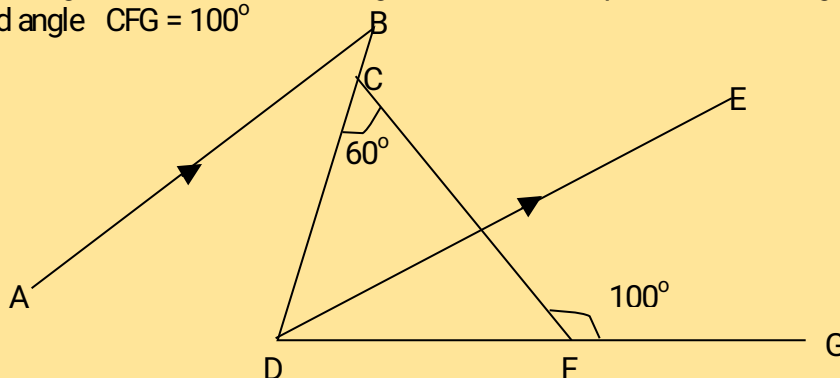

Find the value of angle:-

- (a) CDF  
 (b) ABD
15. The size of an interior angle of a regular polygon is  $4x^\circ$ , while its exterior angle is  $(x - 30)^\circ$ . Find the number of sides of the polygon
16. The sum of interior angles of a polygon is  $1440^\circ$ . Find the number of sides of the polygon

hence name the polygon

17. In the figure below PQ is parallel to RS. Calculate the value of  $x$  and  $y$

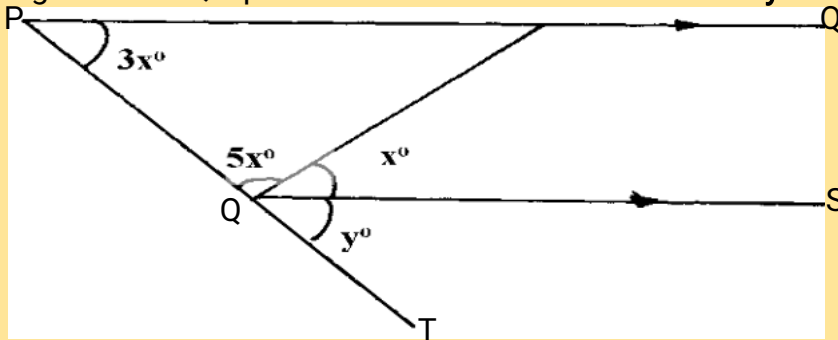

18. The interior angle of a  $n$ -sided regular polygon exceeds its exterior angle by  $132^\circ$ . Find the value of  $n$

### 15. Angles and Plane Figures

1. The sum of angles of a triangle is given by the expression  $(2a+b)^\circ$  while that of a quadrilateral is given by  $(13a - b)^\circ$ . Calculate the values of  $a$  and  $b$  (4 mks)
2. The figure below represents a quadrilateral ABCD. Triangle ABX is an equilateral triangle. If  $\angle ADX = 50^\circ$ , find  $\angle AXD$  with  $\angle BAD = 90^\circ$  (2 mks)

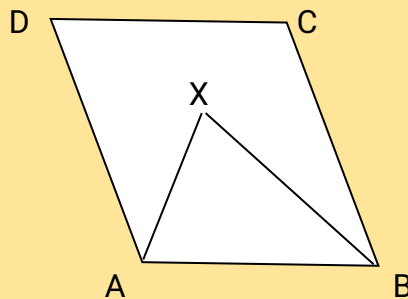

3. Wanjiku is standing at a point P, 160m south of a hill H on a level ground. From point P she observes the angle of elevation of the top of the hill to be  $67^\circ$
- (a) Calculate the height of the hill (3 mks)
- (b) After walking 420m due east to the point Q, Wanjiku proceeds to point R due east of Q, where the angle of elevation of the top of the hill is  $35^\circ$ . Calculate the angle of elevation of the top of the hill from Q (3 mks)
- (c) Calculate the distance from P to R (4 mks)

### 16. Geometrical Constructions

1. Using a ruler and a pair of compasses only,
- a) Construct a triangle ABC in which  $AB = 9\text{cm}$ ,  $AC = 6\text{cm}$  and angle  $BAC = 37\frac{1}{2}^\circ$
- c) Drop a perpendicular from C to meet AB at D. Measure CD and hence find the area of the triangle ABC
- d) Point E divides BC in the ratio 2:3. Using a ruler and Set Square only, determine point E. Measure

AE.

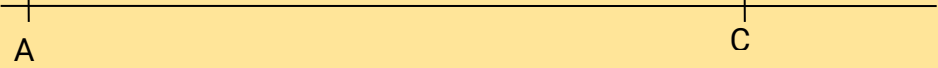
1. Chebochok deposited shs.120,000 in a financial institution which offered a compound interest at 8% p.a, compounded quarterly for 9 months. Find the accumulated amount by the end of the period
2. Using a ruler and a pair of compasses only, draw a parallelogram ABCD in which AB = 6cm, BC = 4cm and angle BAD =  $60^\circ$ . By construction, determine the perpendicular distance between the lines AB and CD
3. Without using a protractor, draw a triangle ABC where  $\angle CAB = 30^\circ$ , AC = 3.5cm and AB = 6cm. measure BC
4. (a) Using a ruler and a pair of compass only, construct a triangle ABC in which angle ABC =  $37.5^\circ$ , BC = 7cm and BA = 14cm  
(b) Drop a perpendicular from A to BC produced and measure its height  
(c) Use your height in (b) to find the area of the triangle ABC  
(d) Use construction to find the radius of an inscribed circle of triangle ABC
5. In this question use a pair of compasses and a ruler only  
a) Construct triangle PQR such that PQ = 6 cm, QR = 8 cm and  $\angle PQR = 135^\circ$   
b) Construct the height of triangle PQR in (a) above, taking QR as the base
6. On the line AC shown below, point B lies above the line such that  $\angle BAC = 52.5^\circ$  and AB = 4.2cm. (*Use a ruler and a pair of compasses for this question*)  

7. Juma paid shs.450 for a trouser after getting a discount of 10%. The trader still made a profit of 25% on the sale. What profit would the trader have made if no discount was allowed?

## 17. Scale Drawing

1. Three mountains Mikai, Kembo and Chaka in a village are situated in such a way that Kembo is 900m on a bearing of  $120^\circ$  from Mikai. Mt. Chaka is 1200m on a bearing of  $030^\circ$  from Kembo.
  - (ii) Draw a sketch showing the position of the three mountains (1 mk)
  - (iii) Calculate the distance of Mt. Chaka from Mt. Mikai (2 mks)
1. Town X is 13.5km from town Y on a bearing of  $028^\circ$ . A matatu leaves Y at 7:35a.m towards a bearing of  $080^\circ$ . The matatu is at point Z due south of X at 8:55a.m
  - (a) Calculate the average speed of the matatu from Y to Z
  - (b) If the matatu continues on the same bearing, calculate the distance it covers from Z when it is East of X

2. Three towns X, Y and Z are such that Y is 500km on a bearing of  $315^\circ$  from X. Z is on a bearing of  $230^\circ$  from X. given that the distance between Y and Z is 800km
- using a scale of 1cm to represent 100km, draw a scale diagram to show the position of the Towns
  - Find the bearing of;
    - X from Z
    - Z from Y
  - Use the scale drawing to find the distance from X to Z
3. Two aeroplanes **S** and **R** leave an airport at the same time. **S** flies on the bearing of  $240^\circ$  at 750Km/h while **R** flies due East at 600Km/hr..
- (i) Calculate the distance of each aeroplane after 30minutes  
(ii) Using a scale of 1cm to represent 50km make an accurate scale drawing to show the positions of the aeroplanes after 30minutes
  - (i) Use the scale drawing to find the distance between the two aeroplanes after 30minutes  
(ii) If each aeroplane landed after 30minutes and **S** received a signal to join **R** in 45minutes. Find its speed
  - Determine the bearing of :
    - S** from **R**
    - R** from **S**

4. The table below gives a field book showing the results of a survey of a section of a piece of land between A and E. All measurements are in metres.

	<b>E</b>	
<b>D</b> 33	95	
	90	<b>F</b> 36
<b>C</b> 21	70	
<b>B</b> 42	30	<b>G</b> 25
	25	<b>H</b> 40
	<b>A</b>	

- Draw a sketch of the land.
  - Calculate the area of this piece of land.
5. Three towns A B and C are situated such that town A is 40km from B on a bearing of  $280^\circ$ . C is 60km from B on a bearing of  $130^\circ$ . Another town D is only 10km from C on a bearing of  $210^\circ$ .
- Drawing accurately and using a scale of 1cm to 10km find the:-
  - Distance from A to C and the bearing of A from C
  - (i) Distance of B from D  
(ii) Distance of A from D  
(iii) Bearing of A from D  
(iv) Bearing of C from D
6. A train left Naivasha for Nakuru at 1000hours. It traveled at an average speed of 45km/h and reached Gilgil after 40minutes. It then covered the remaining 50km in  $1\frac{1}{2}$  hours. A second train left Nakuru for Naivasha at 1015 hours and arrived at Gilgil at the same time as the first train arrived at Nakuru.
- Using a scale of 1cm to represent 10minutes in the time axis and 1cm to represent 10km on the distance axis, draw on the same axes the graphs to show the movement of the two trains
  - use your graph to find;
    - the distance between Naivasha and Nakuru
    - the time at which the train met
  - calculate the average speed, in km/h of the second train

7. On a certain map, a road 20km long is represented by a line 4cm long. Calculate the area of a rectangular plot represented by dimensions 2.4cm by 1.5cm on this map – leaving your answer in hectares
8. A port **B** is on a bearings of  $080^\circ$  from a port **A** and at a distance of 95km. a submarine is stationed at a port **D**, which is on a bearing of  $200^\circ$  from **A**, and a distance of 124km from **B**. A ship leaves **B** and moves directly southwards to an island **P**, which is on a bearing of  $140^\circ$  from **A**. the submarine at **D** on realizing that the ship was heading for the island **P**, decides to head straight for the island to intercept the ship.
- (a) Using a scale of 1cm to represent 10km draw a diagram to show the positions of **A**, **B**, **D**, and **P**
- (b) Hence;
- Determine;**
- (i) the distance from **A** to **D**
- (ii) the bearing of the submarine from the ship when the ship was setting off from **B**
- (iii) the bearing of the island **P** from **D**
- (iv) the distance the submarine had to cover to reach the island **P**
9. Use a scale of 1cm represents 50km in these questions. Five towns **A**, **B**, **C**, **D** and **E** are situated such that **A** is 200 km from **B** on a bearing of  $050^\circ$  from **E**. **C** is 300 km from **B** on a bearing of  $150^\circ$  from **B**. **D** is 350km on a bearing of  $240^\circ$  from **C**. **E** is 200km from **D** and the bearing of **D** from **E** is  $100^\circ$
- a) Draw the diagram representing the positions of the towns
- b) From the diagram, determine;
- i) The distance in km of **A** from **E**
- ii) The bearing of **D** from **B**
10. Four towns **P**, **Q**, **R** & **S** are such that **P** is 280 km North of **R**, **S** is 190 km from **R** on a bearing of  $310^\circ$  and **Q** is 240 km from **P** on a bearing of  $105^\circ$ .
- a) Using scale of 1 cm rep. 50 km, locate the four towns.
- b) Find; (i) distance **SQ**.
- (ii) Bearing of **S** from **Q**.
- (iii) The shortest distance between **P** and side **QR**.
11. Four ships are at sea such that a streamliner **S** is 150km on a bearing of  $025^\circ$  from a cargo ship **C**. A trawler **T** is 300km on a bearing of  $145^\circ$  from the cargo ship and a yacht **Y** is due West of **C** and on a bearing of  $300^\circ$  from **T**.
- a) Using a scale of 1cm= 50km, draw on accurate scale drawing showing the positions of **S**, **C**, **T** and **Y**
- b) By measurement from your scale drawing determine:
- i) The distance and bearing of **Y** from **S**
- ii) The distance **ST**
- iii) The distance **YT**
12. A tea farm in Kakamega forest was surveyed and the results were recorded in the surveyors note book as shown below. The measurements are in meters

	<b>250</b>	<b>Y</b>
	240	D70
C80	170	
	70	B60
A60	50	
<b>X</b>	<b>0</b>	

Using a scale of 1: 25, draw the map of the plot and hence calculate the area of the plot in Hectares



13. The information below shows the entries in a surveyor's field book after a survey of a farm. XY = 280m is the baseline. All measurements are in metres

	280	Y
B 105	230	110E
	190	
	160	45E
A 100	90	
	40	95G
X	0	

- (a) Use a scale of 1 cm represents 20m to draw the map of the farm  
 (b) Estimate the area of the farm in hectares  
 (c) If the point Y lies due north of X, find correct to 1 decimal place, the :  
 (i) Bearing of E from X  
 (ii) Distance of E from X
14. The measurements of a flower garden were recorded in a surveyor's field book as shown.

	250	Y
C80	240	D 70
	170	
	70	B 60
X	0	

Draw a sketch of the field and find its area. (Measurements are in m)

15. A map has a scale 1:40,000:  
 (a) Calculate the distance between two points on the ground if the corresponding distance shown on the map is 3.25cm  
 (b) Calculate the area in the map of woodland which occupies 36ha on the ground
16. Three scouts John, Peter and Samwel stand on three adjacent peaks of equal altitude on mountain range. The distance between John and Peter is 800metres and the bearing of Peter from John is  $020^\circ$ . The distance between John and Samwel is 1500metres, and the bearing of Samwel from John is  $320^\circ$ .  
 (a) Calculate the bearing of John from Peter  
 (b) **Calculate**- (i) the distance  
 (ii) the bearing of Samwel from Peter

17. The figure below represents a surveyor's sketch of a plot of land. Calculate the area of the plot in square metres given that XY = 50m, XK = 20m, XM = 25m, XL = 35m, KA = 40m, MD = 38m and LB = YC = 60m.

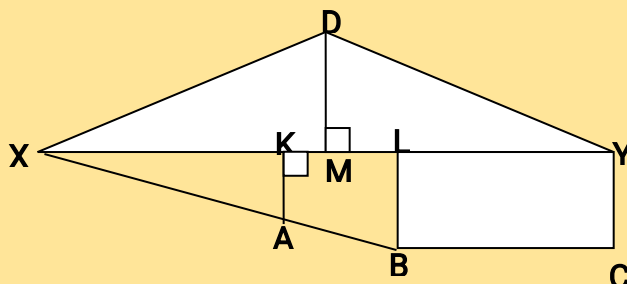

18. Two boats P and Q are located 30km apart; P being due North of Q. An observer at P spots a ship whose bearing he finds as S  $56^\circ$ E from Q, the bearing of the same ship is  $038^\circ$ . Calculate the distance of the ship from Q to 2 decimal places
19. A map is drawn to scale of 1:100,000. What area in  $\text{km}^2$ , is represented by a rectangle measuring 4.5cm by 5.4 cm

21. Two places **A** and **B** are 900km apart on the earth's surface. If **A** is due North of **B** and given that the latitude of **A** is  $5^{\circ}\text{N}$ . Find the latitude of **B**. (Take radius of the earth to be 6370km)

22. A car starts from rest and build up a speed of  $40\text{m/s}$  in  $1\text{min } 40\text{seconds}$ . It then travels at this steady speed for  $5\text{minutes}$ . Brakes are then applied and the car is brought to rest in  $2\text{minutes}$ .
- (a) Draw a velocity-time graph to show the journey  
 (b) Use your graph to find;  
 (i) the initial acceleration  
 (ii) the deceleration when the car is brought to rest  
 (iii) the distance traveled

23. The diagram below represents two vertical watch-towers AB and CD on a level ground. P and Q are two points on a straight road BD. The height of the tower AB is  $20\text{m}$  and road BD is  $200\text{m}$

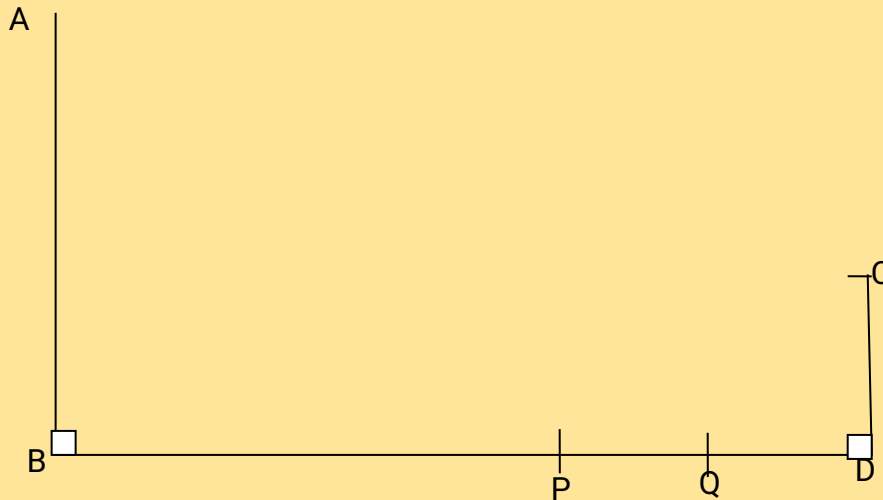

- (a) A car moves from B towards D. At point P, the angle of depression of the car from point A is  $11.3^\circ$ . Calculate the distance BP to 4 significant figures  
 (b) If the car takes 5 seconds to move from P to Q at an average speed of  $36\text{km/hr}$ . Calculate the angle of depression of Q from A to 2 decimal places  
 (c) Given that  $QC = 50.9\text{m}$ , calculate;  
 (i) the height of CD in metres to 2 decimal places  
 (ii) the angle of elevation of A from C to the nearest degree
24. Town B is  $180\text{ km}$  on a bearing of  $050^\circ$  from town A. Another town C is on a bearing of  $110^\circ$  from town A and on a bearing of  $150^\circ$  from town B. A fourth town D is  $240\text{ km}$  on a bearing of  $320^\circ$  from A. Without using a scale drawing, calculate to the nearest kilometer.  
 (a) The distance AC  
 (a) The distance CD

### 18. Common solids

1. The figure below represents a square based solid with a path marked on it

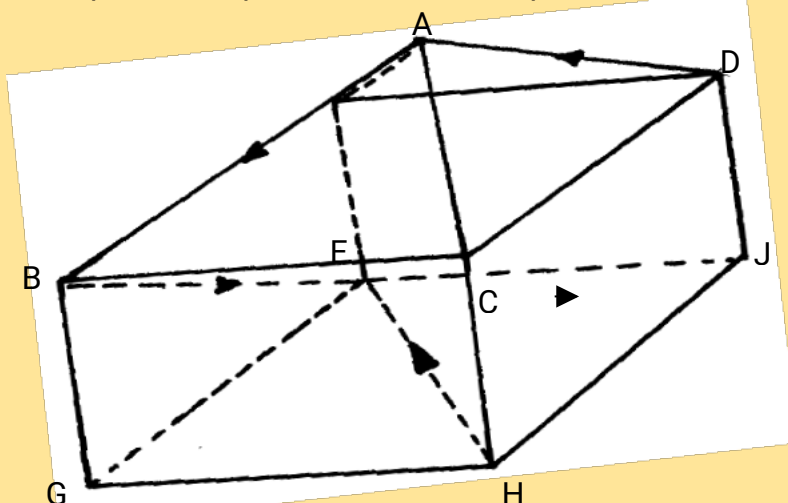

2. Sketch and label the net of the solid  
The below shows a solid prism:-

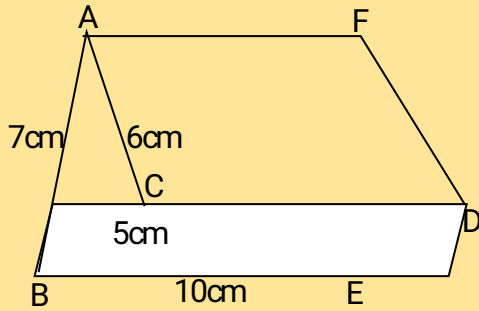

- (a) Sketch the net of the prism above  
(b) Use the net in (a) above to calculate the total surface area of the material used in making the solid
3. Draw the solid whose net is shown below.

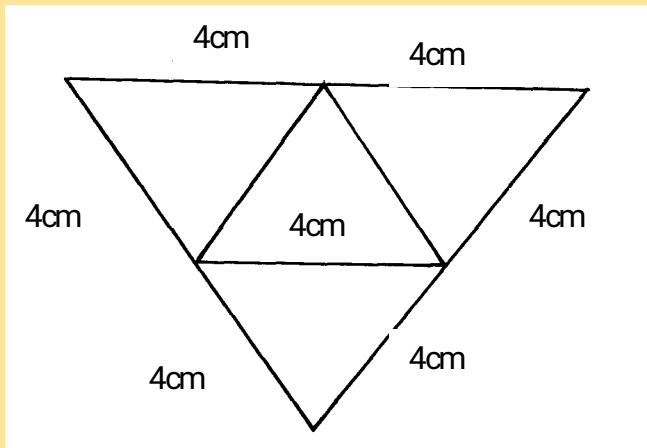

4. Sketch the net of the solid shown in the figure below, measurements are in centimeters

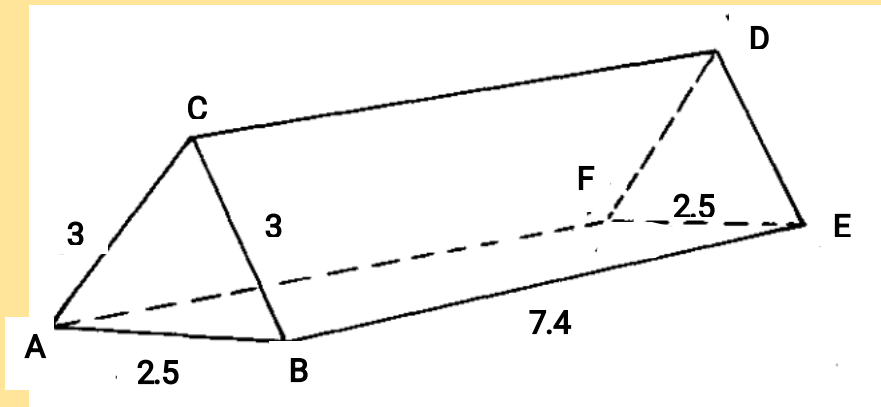

### 19. Indices

- Evaluate the value of x in  $8^{x+1} + 3^{4x} = 246$ .
- Solve for y in the equation:-  $5^{(2y+1)} = 4(5)^{y+1} - 15$
- Without logarithm tables or calculators, evaluate:  $\frac{25^{3/4} \times 0.9^2 \times 2^2}{5^{-5} \times 3^3}$  in the form A/B where A and B are integers

4. Find the value of  $x$  given that :  
 $2^x = 0.0625$  ( $x$  is an integer)
6. Find the value of  $x$  which satisfies the equation  $16^{x^2} = 8^{4x-3}$
7. Solve the equation;  
 $9^{x+1} + 3^{2x+1} = 36$
8. By letting  $P = 4^y$  in the equation:  
 $4^{-2y+1} - 3 \times 4^y - 10 = 0$   
 (a) Write the above equation in terms of  $P$   
 (b) Hence find the possible values of  $y$
9. Solve for  $x$  in the equation.
10. In the expansion of  $(ax - \frac{2}{x^2})^6$  the constant term is 4860. Find the value of  $a$ .

## 20. Reciprocals

1. Use reciprocal, square and square root tables to evaluate, to 4 significant figures, the expression.

$$\sqrt{\frac{1}{24.56} + 4.346^2} \quad (3 \text{ mks})$$

1. Use reciprocal table to evaluate giving your answer to three significant figures.

$$\frac{10}{0.834} - \frac{3}{129.64}$$

2. Find the reciprocals of the numbers 807 and 0.0591;

Hence evaluate  $\frac{5}{807} + \frac{4}{0.0591}$

3. Use reciprocal tables to find the value of:

$$\frac{1}{3} \left\{ \frac{2}{0.6638} + \frac{5}{0.833} \right\}$$

4. Find without using a calculator, the value of:

$$\frac{12\sqrt{0.0625} - 12.4 \div 0.4 \times 3}{\frac{1}{8} \text{ of } 2.56 + 8.68}$$

5. Use tables of cubes, cube roots and reciprocal to find the value of:-

$$\frac{4}{(8.68)^3} + \left( \frac{5}{34.46} \right)^{1/3}$$

6. Determine the value of  $a$  for which  $\frac{1}{127} + \frac{1}{11.5a} = \frac{1}{a}$  Use mathematical tables only

7. Use tables of squares, square roots and reciprocals only to find the value of  $x$  correct to 4 significant figures:

$$x = \sqrt{\frac{1}{3.593^2} + \frac{2}{0.526}}$$

8. Use reciprocal tables to find the value of;

$$\frac{1}{3} \left\{ \frac{2}{0.6638} + \frac{5}{0.833} \right\}$$

9. Use tables of reciprocals only to work out;

$$\frac{3}{0.6735} + \frac{13}{0.156}$$

10. Using tables of squares, cube roots and reciprocals find the value of  $x$ .

$$\frac{1}{x} = \frac{1}{0.002593^{1/3}} - \frac{1}{1.28^2}$$

## 21. Common Logarithms

1. Use mathematical table to evaluate.

$$\frac{2849 \times 0.00574}{36.89 \div 0.023}$$

2. Given that  $y = Bx^n$ . Make  $n$  the subject of the formula and simplify your answer

3. Without using mathematical tables or calculators evaluate:  $6\log_2 64 + 10\log_3 (243)$

4. Find the value of  $x$  that satisfies the equation  $\log (2x - 11) - \log 2 = \log 3 - \log x$

5. Use logarithms to evaluate to 3 significant figures

$$\frac{(0.5241)^2 \times 83.59}{\sqrt[3]{0.3563}}$$

6. Use logarithm tables in all your steps to evaluate:

$$\sqrt[3]{\frac{38.32 \times 12.964}{86.37 \times 6.285}}$$
 leaving your answer to four decimal places

7. Make  $L$  the subject in :

$$H = 3 \sqrt{\left( \frac{3d(L-d)}{10L} \right)}$$

8. Using logarithm tables solve.

$$\left( \frac{6.195 \times 11.82}{83.52} \right)^{1/4}$$

9. Solve the simultaneous equation:-

$$\begin{aligned} \log (x-1) + 2\log y &= 2\log 3 \\ \log x + \log y &= \log 6 \end{aligned}$$

10. Without using logarithms tables or calculator evaluate:-

$$\frac{4 \log_{10} 32 + \log_{10} 50 - 3\log_{10} 2}{5}$$

11. Use logarithms to evaluate:-

$$\frac{6.598}{(0.9895)^2 \times 0.004974^{0.75}}$$
 and express the answer in standard form

12. Solve for  $x$  given that :-  $\log (3x + 8) - 3\log 2 = \log (x-4)$

13. In this question, show all the steps in your calculations, giving your answer at each stage. Use logarithms correct to 4 decimal places to evaluate:

$$\sqrt[3]{\frac{36.72 \times (0.46)^2}{185.4}}$$

14. Use logarithms to evaluate correct to 4 s.f

$$\left( \frac{\sin 44.5}{\tan 14.90 \times \cos 82} \right)^{\frac{1}{2}}$$

15. Without using logarithm tables evaluate:

$$\sqrt[3]{\frac{3.264 \times 1.215 \times \sqrt{12.25}}{1.088 \times 0.4725}}$$

16. Without using a calculator/mathematical tables, solve:  $\text{Log}_8(x+5) - \text{log}_8(x-3) = \text{Log}_8 4$
17. Use tables to calculate;  $(6.57^2 + 6.57) \div (7.92^2 \times 30.08)$  (Give your answer to 4 decimal places)
18. If  $\log^e = 0.30103$ , and  $\log^e = 0.47712$ , calculate without using tables or calculators the value of  $\log_{120}$
19. Solve for x in the following equation;  $\text{Log}_2(3x-4) = \frac{1}{3} \log_2 8x^6 - \log_2 4$
20. By showing all the steps, use logarithms to evaluate:  $\frac{5.627 \times (0.234)^3}{(8.237)^{\frac{1}{2}}}$
21. Solve the logarithmic equation:  $\log_{10}(6x-2) - 1 = \log_{10}(x-3)$

22. In this question, show all the steps in your calculations, giving your answers at each stage. Use logarithms, correct to 4 d.p to evaluate:-

$$\sqrt[3]{\frac{(0.07526)^2}{1.789 + 4.863}}$$

23. Evaluate using logarithms

$$\sqrt{\frac{4.283 \times (0.009478)^2}{\text{Log } 9.814}}$$

## 22. Equations of straight lines

- A solid right pyramid has a rectangular base 10cm by 8cm and slanting edge 16cm calculate:
  - The vertical height
  - The total surface area
  - The volume of the pyramid
- The line passing through the points A (-1, 3K) and B (K, 3) is parallel to the line whose equation is  $2y + 3x = 9$ . Write down the co-ordinates of A and B
- Find the value of **a** if the gradient of the graphs of the function  $y = x^2 - x^3$  and  $y = x - ax$  are equal at  $x = \frac{1}{3}$



4. Two perpendicular lines meet at the point (4,5). If one of the lines passes through the point (-2,1), determine the equation of the second line in the form  $ax + by + c = 0$ .
5. Find the equation of the line passing through (-5, 2) and with X-intercept as 3. Leave your answer in the form of  $Y = mX + C$

6. (a) copy and complete the table below.

x	0	1	2	3	4	5	6
$y = 2x - 4$							
$y = 12 - 2x$							

- (b) (i) On the grid provided and using the same axes, draw the lines  $y = 2x + 4$  and  $y = 12 - 2x$   
(ii) Hence use your graphs to solve the simultaneous equations

$$\frac{1}{2}x - \frac{1}{4}y = 1$$

$$x + \frac{1}{2}y = 6$$

- (c) By use of substitution method, solve the simultaneous equations;

$$6x + 4y = 36$$

$$x + 3y = 13$$

7. Find the equation of a line through point (-2, 4) which is parallel to  $3y = -2x + 8$ . Express your answer in the form  $y = mx + c$ .
8. Determine the equation of a line passing through (-1, 3) and parallel to the line whose equation is  $3x - 5y = 10$
9. On a certain map, a road 20km long is represented by a line 4cm long. Calculate the area of a rectangular plot represented by dimensions 2.4cm by 1.5cm on this map – leaving your answer in hectares
10. A straight line passing through point (-3,4) is perpendicular to the line whose equation is  $2y - 5x = 11$  and intersects the x-axis and y-axis at the points P and Q respectively. Find the co-ordinates of P and Q
11. A triangle ABC is formed by the points A(3, 4), B(-7, 2) and C(1, -2)  
(a) Find the co-ordinates of the mid-points K of AB and P of AC  
(b) Find the equation of the perpendicular bisector of the KP
12. The equation of line  $L_1$  is  $-\frac{3}{5}x + 3y = 6$ . Find the equation of a line  $L_2$  passing through point T(1, 2) and perpendicular to line  $L_1$
13. Determine the equation of a line passing through (-1, 3) and parallel to the line whose equation is  $3x - 5y = 10$
14. A straight line through the points A(2, 1) and B(4, m) is perpendicular to the line, whose equation is  $3y = 5 - 2x$ . Determine the value of m
15. Determine the equation of a line which is perpendicular to the line  $2x + 3y + 4 = 0$  and passes through P(1,1)
16. Koech bought 144 pineapples at shs.100 for every six pineapples. She sold some of them at shs.72 for every three and the rest at shs.60 for every two. If she made a profit of 40%; Calculate the number of pineapples sold at 72 for every three
17. Solve the equation  $\frac{x+2}{3} - \frac{x-1}{2} = 5$

## 23. Reflection and Congruence

1. Given that  $A'$  (3, -3) is the image of  $A$  (-1, -5) under a reflection. Find the equation of the mirror line in the form of  $ax + by + c = 0$  (4 mks)

1. Three planes **A**, **B** and **C** leave an airport **P** simultaneously at 9.30a.m. Plane **A** flies on a bearing of  $070^\circ$  from **P** at a speed of 400km/h. Plane **B** flies on a bearing of  $290^\circ$  at a speed of 500km/h. Plane **C** flies on a bearing of  $162^\circ$  from **P** at a speed of 300km/h.

*(Use scale drawing for this question)*

- (a) Show by scale drawing, the relative positions of the 3 planes **A**, **B** and **C** three hours after leaving airport **P**. (Use scale 1 cm represents 200km)
- (b) After 3 hours, **B** turns and head straight to the current position of **A** at the same speed it had. Determine the scale drawing, the time it takes to reach this point, to the nearest minute
- (c) Determine the bearing and distance of **B** from **C** after the first 3 hours of flight after leaving **P**

## 24. Rotation

1. The ratio of the lengths of the corresponding sides of two similar rectangular water tanks is 3: 5. The volume of the smaller tank is  $8.1\text{m}^3$ . Calculate the volume of the larger tank

## 25. Similarities and Enlargement

1. Two tanks are similar in shape. The capacity of the tanks are 1,000,000 litres and 512, 000 litres respectively.
- (a) Find the height of the smallest tank if the larger is 300cm tall (4 mks)
- (b) Calculate the surface area of the larger tank if the smaller tank has a surface area of  $1200\text{m}^2$  (3 mks)
- (c) Estimate the mass of the smaller tank if the mass of the larger one is 800kg (3 mks)
1. The image of  $P(0,2)$  under an enlargement with a scale factor 3 is  $P^1(4,6)$ . Find the co-ordinates of  $Q$
2. A model of a building is made using a scale 1:500.
- (a) Find the height of a room (in metres) in the building which is 5cm long on the model? **S\*\*\***
- (b) A room has a floor area of  $36\text{m}^2$ . What is the corresponding area on the floor of the model
- (c) A room has a volume of  $120\text{m}^3$ . What is the corresponding volume of the model in  $\text{cm}^3$ ? **S\*\*\***
3. In the triangle  $ABD$ ,  $BA$  is parallel, to  $CE$ , given that  $BA = 9\text{cm}$ ,  $CE = 4\text{cm}$  and  $AE = 3\text{cm}$ , find the length of  $DE$

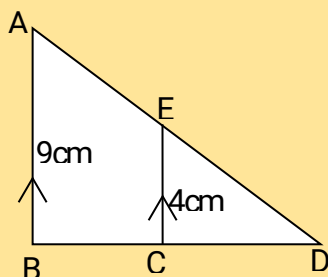

4. In the following figure,  $PR = 12\text{cm}$ ,  $TR = 4\text{cm}$  and  $ST$  is parallel to  $QR$ . Given that the area of triangle  $PQR$  is  $336\text{cm}^2$ , find the area of quadrilateral  $QRTS$

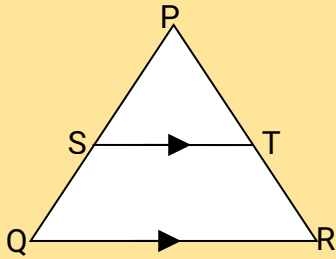

5. Two dogs regarded similar with the length in ratio 4:3:-  
 (a) If the bigger dog has a tail 64cm long, find the length of the tail of the smaller dog  
 (b) If the smaller dog requires 810g of meat per day how much meat per day does the bigger dog require
6. In the figure below,  $ADE$  is a triangle and  $BC$  is parallel to  $DE$ ,  $AB$ ,  $BD$  and  $BC$  are 4cm, 3cm and 8cm respectively.

Find the length of  $DE$

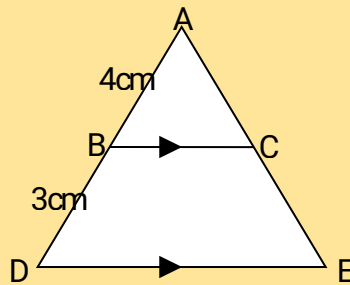

7. The surface area of two similar bottles are  $12\text{cm}^2$  and  $108\text{cm}^2$  respectively. If the larger one has a volume of  $810\text{cm}^3$ . Find the volume of the smaller one

8. Given that the area of the trapezium CDEB is  $15.6 \text{ cm}^2$ , find the length EA marked X.

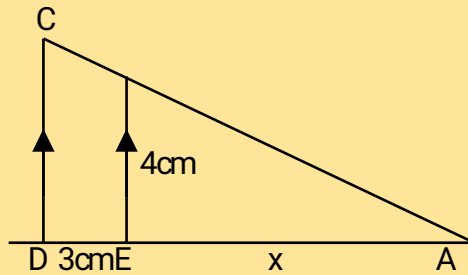

## 26. The Pythagoras theorem

- The angle of elevation of the top of a tree from a point P on the horizontal ground is  $24.5^\circ$ . From another point Q, five metres nearer to the base of the tree, the angle of elevation of the top of the tree is  $33.2^\circ$ . Calculate to one decimal place, the height of the tree
- A block of wood in the shape of a frustrum of a cone of slanting edge 30 cm and base radius 10cm is cut parallel to the base, one third of the way from the base along the slanting edge. Find the ratio of the volume of the cone removed to the volume of the complete cone.

## 27. The Trigonometric Ratio 1

- At point A, David observed the top of a tall building at an angle of  $30^\circ$ . After walking for 100meters towards the foot of the building he stopped at point B where he observed it again at an angle of  $60^\circ$ . Find the height of the building
- Find the value of  $\theta$ , given that  $\frac{1}{2} \sin\theta = 0.35$  for  $0^\circ \leq \theta \leq 360^\circ$
- A man walks from point A towards the foot of a tall building 240 m away. After covering 180m, he observes that the angle of elevation of the top of the building is  $45^\circ$ . Determine the angle of elevation of the top of the building from A
- The table below gives a field book showing the results of a survey of a section of a piece of land between A and E. All measurements are in metres.

	<b>E</b>	
<b>D</b> 33	95	
	90	<b>F</b> 36
<b>C</b> 21	70	
<b>B</b> 42	30	<b>G</b> 25
	25	<b>H</b> 40
	<b>A</b>	

- Draw a sketch of the land.
  - Calculate the area of this piece of land.
- Solve for x in  $2 \cos 2x = 0.6000$   $0^\circ \leq x \leq 360^\circ$ .
  - Wangechi whose eye level is 182cm tall observed the angle of elevation to the top of her house to be  $32^\circ$  from her eye level at point A. she walks 20m towards the house on a straight line to a point B at which point she observes the angle of elevation to the top of the building to be  $40^\circ$ . Calculate, correct to 2 decimal places the ;
    - distance of A from the house
    - The height of the house
  - Given that  $\cos A = \frac{5}{13}$  and angle A is acute, find the value of:-  
 $2 \tan A + 3 \sin A$

8. Given that  $\tan 5^\circ = \frac{3}{5}$ , without using tables or a calculator, determine  $\tan 25^\circ$ , leaving your answer in the form  $a + b\sqrt{c}$
9. A student whose eye level is 182cm from the ground observed the top of their house at an angle of elevation of  $32^\circ$  at point **A**. She walked for 20m towards the house along a straight road to a point **B**, where she observed the top of the building again at an angle of elevation of  $40^\circ$ . Calculate correct to 2 decimal places the:-  
 (a) Distance of **A** from the house  
 (b) The height of the house
10. Given that  $\tan x = \frac{5}{12}$ , find the value of the following without using mathematical tables or calculator:  
 (a)  $\cos x$   
 (b)  $\sin^2(90-x)$
11. If  $\tan \theta = \frac{8}{15}$ , find the value of  $\frac{\sin \theta - \cos \theta}{\cos \theta + \sin \theta}$  without using a calculator or table

## 28. Area of a triangle

1. The figure below represents a triangular plot ABC. The lengths of AB = 50m, AC = 80m and angle BAC =  $30^\circ$

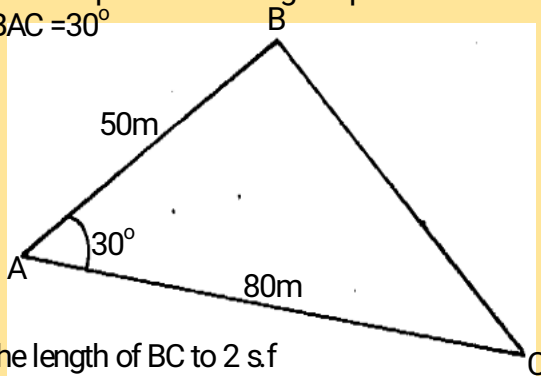

- (a) Find the length of BC to 2 s.f  
 (b) Find the area of the plot in hectares  
 (c) The plot is fenced using 4 strands of barbed wire. The length of one roll of barbed wire is 600m and it costs shs.4000. Calculate;  
 (i) The length of fencing wire required  
 (ii) The number of complete rolls to be bought  
 (iii) The cost of the rolls

## 29. Area of polygons

1. Find the area of a regular polygon of length 10 cm and side  $n$ , given that the sum of interior angles of  $n : n - 1$  is in the ratio 4 : 3.
2. Calculate the area of the quadrilateral ABCD shown:-

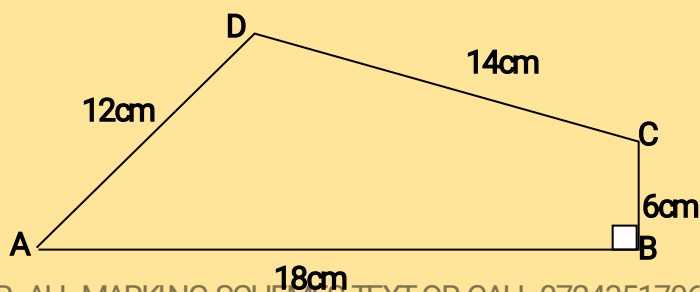

### 30. Area of part of a circle

1. The ends of the roof of a workshop are segments of a circle of radius 10m. The roof is 20m long. The angle at the centre of the circle is  $120^\circ$  as shown in the figure below.

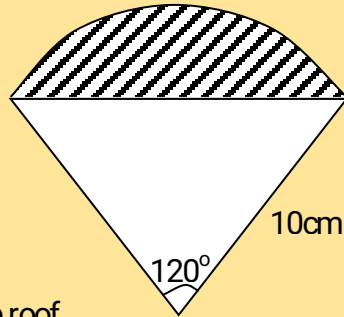

(a) Calculate :-

- (i) The area of one end of the roof
- (ii) The area of the curved surface of the roof

(b) What would be the cost to the nearest shilling of covering the two ends and the curved surface with galvanized iron sheets costing shs.310 per square metre

2. The diagram below, not drawn to scale, is a regular pentagon circumscribed in a circle of radius 10cm at centre O

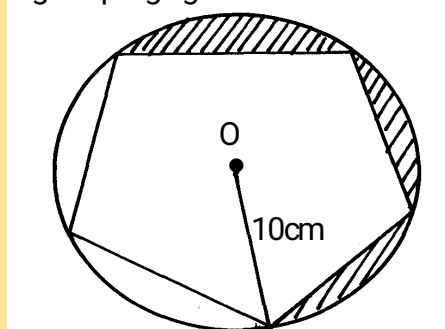

Find;

- (a) The side of the pentagon
- (b) The area of the shaded region

3. Triangle PQR is inscribed in the circle PQ= 7.8cm, PR = 6.6cm and QR = 5.9cm. Find:

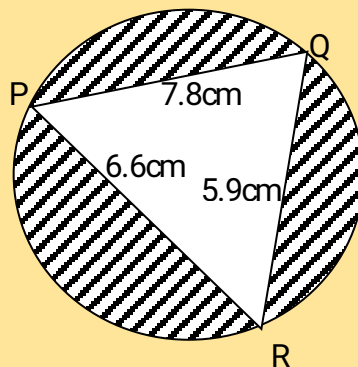

- (a) The radius of the circle, correct to one decimal place
- (b) The angles of the triangle
- (c) The area of shaded region

4. The figure below represents sector OAC and OBD with radius OA and OB respectively. Given that OB is twice OA and angle AOC =  $60^\circ$ . Calculate the area of the shaded region in  $m^2$ , given that OA = 12cm

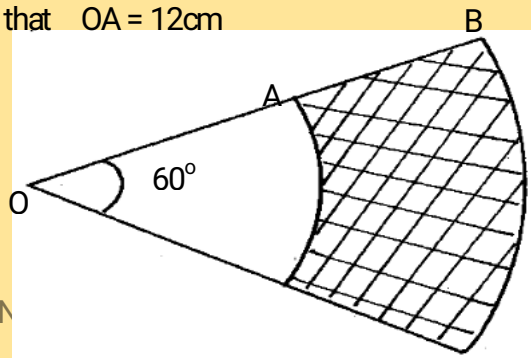

C

D

### 31. Surface Area of Solids

1. A swimming pool water surface measures 10m long and 8m wide. A path of uniform width is made all round the swimming pool. The total area of the water surface and the path is  $168\text{m}^2$
- (a) Find the width of the path (4 mks)
- (b) The path is to be covered with square concrete slabs. Each corner of the path is covered with a slab whose side is equal to the width of the path. The rest of the path is covered with slabs of side 50cm. The cost of making each corner slab is sh 600 while the cost of making each smaller slab is sh.50. Calculate
- (i) The number of the smaller slabs used (4 mks)
- (ii) The total cost of the slabs used to cover the whole path (2 mks)

1. A lampshade is in the form of a frustrum of a cone. Its bottom and top diameters are 12cm and 8cm respectively. Its height is 6cm. Find;
- (a) The area of the curved surface of the lampshade
- (b) The material used for making the lampshade is sold at Kshs.800 per square metre. Find the cost of ten lampshades if a lampshade is sold at twice the cost of the material
2. A cylindrical piece of wood of radius 4.2cm and length 150cm is cut lengthwise into two equal pieces. Calculate the surface area of one piece
3. The base of an open rectangular tank is 3.2m by 2.8m. Its height is 2.4m. It contains water to a depth of 1.8m. Calculate the surface area inside the tank that is not in contact with water
4. The figure below represents a model of a solid structure in the shape of frustrum of a cone with a hemisphere top. The diameter of the hemispherical part is 70cm and is equal to the diameter of the top of the frustrum. The frustrum has a base diameter of 28cm and slant height of 60cm.

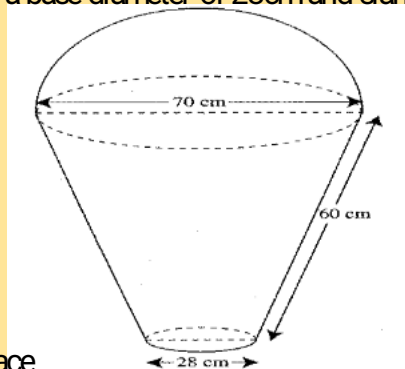

**Calculate :**

- (a) the area of the hemispherical surface
- (b) the slant height of cone from which the frustrum was cut
- (c) the surface area of frustrum
- (d) the area of the base
- (e) the total surface area of the model
5. A room is 6.8m long, 4.2m wide and 3.5m high. The room has two glass doors each measuring 75cm by 2.5m and a glass window measuring 400cm by 1.25m. The walls are to be painted except the window and doors.
- a) Find the total area of the four walls



- b) Find the area of the walls to be painted  
 c) Paint **A** costs Shs.80 per litre and paint **B** costs Shs.35 per litre. 0.8 litres of **A** covers an area of  $1\text{m}^2$  while 0.5 $\text{m}^2$  uses 1 litre of paint **B**. If two coats of each paint are to be applied. Find the cost of painting the walls using:  
 i) Paint **A**  
 ii) Paint **B**  
 d) If paint A is packed in 400ml tins and paint B in 1.25litres tins, find the least number of tins of each type of paint that must be bought.

6. The figure below shows a solid frustum of pyramid with a square top of side 8cm and a square base of side 12cm. The slant edge of the frustum is 9cm

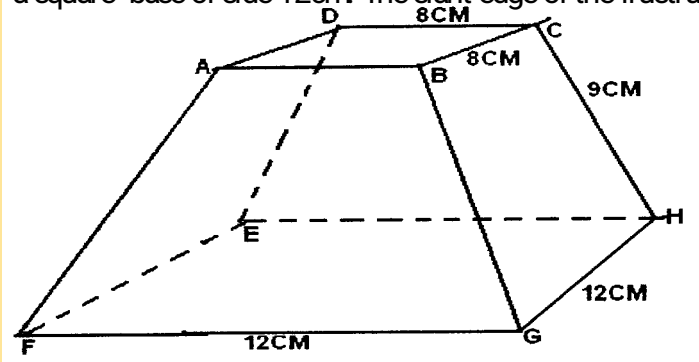

Calculate:

- (a) the total surface area of the frustum  
 (b) the volume of the solid frustum  
 (c) the angle between the planes BCHG and the base EFGH.

### 32. Volume of solids

1. Metal cube of side 4.4cm was melted and the molten material used to make a sphere. Find to 3 significant figures the radius of the sphere  $\left( \text{take } \pi = \frac{22}{7} \right)$  (3 mks)

1. A solid right pyramid has a rectangular base 10cm by 8cm and slanting edge 16cm calculate:  
 (a) The vertical height  
 (b) The total surface area  
 (c) The volume of the pyramid

2. A solid cylinder of radius 6cm and height 12cm is melted and cast into spherical balls of radius 3cm. Find the number of balls made

3. The sides of a rectangular water tank are in the ratio 1: 2:3. If the volume of the tank is  $1024\text{cm}^3$ . Find the dimensions of the tank. (4s.f)

4. The figure below represents sector OAC and OBD with radius OA and OB respectively. Given that OB is twice OA and angle AOC =  $60^\circ$ . Calculate the area of the shaded region in  $\text{m}^2$ , given that OA = 12cm

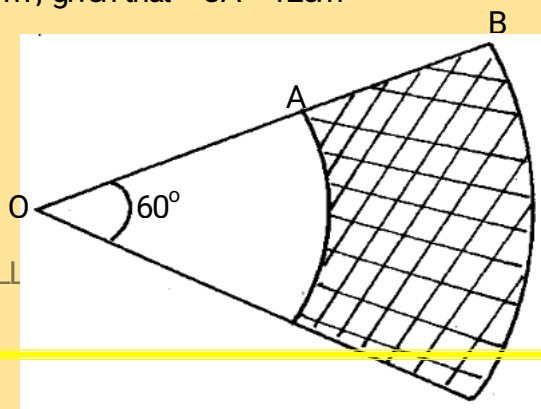

C

D

5. The figure below shows a closed water tank comprising of a hemispherical part surmounted on top of a cylindrical part. The two parts have the same diameter of 2.8cm and the cylindrical part is 1.4m high as shown:-

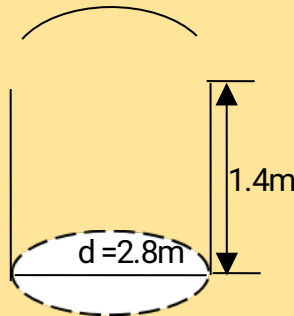

- (a) Taking  $\pi = \frac{22}{7}$ , calculate:
- The total surface area of the tank
  - the cost of painting the tank at shs.75 per square metre
  - The capacity of the tank in litres
- (b) Starting with the full tank, a family uses water from this tank at the rate of 185litres/day for the first 2days. After that the family uses water at the rate of 200 liters per day. Assuming that no more water is added, determine how many days it takes the family to use all the water from the tank since the first day

6. The figure below represents a frustrum of a right pyramid on a square base. The vertical height of the frustrum is 3 cm. Given that  $EF = FG = 6$  cm and that  $AB = BC = 9$  cm

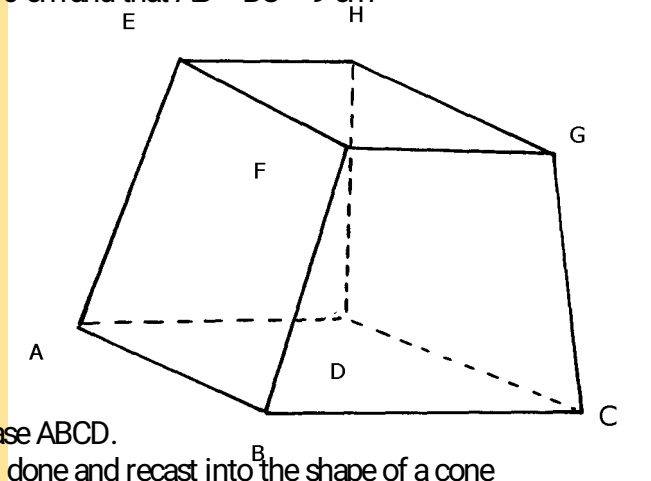

Calculate;

- The vertical height of the pyramid.
  - The surface area of the frustrum.
  - Volume of the frustrum.
  - The angle which line AE makes with the base ABCD.
7. A metal hemisphere of radius 12cm is melted down and recast into the shape of a cone of base radius 6cm. Find the perpendicular height of the cone
8. A solid consists of three discs each of  $1\frac{1}{2}$  cm thick with diameter of 4 cm, 6 cm and 8 cm respectively. A central hole 2 cm in diameter is drilled out as shown below. If the density of material used is  $2.8 \text{ g/cm}^3$ , calculate its mass to 1 decimal place

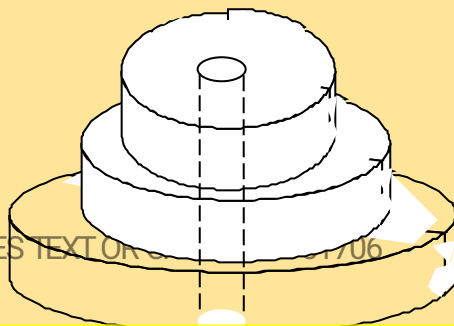

9. A right conical frustrum of base radius 7 cm and top radius 3.5 cm and height 6 cm is stuck onto a cylinder of base radius 7 cm and height 5 cm which is further attached to form a closed solid as shown below.

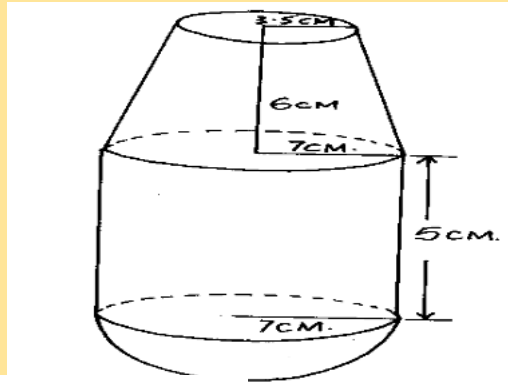

Find;

- The volume of the solid.
- The surface area of the solid.

10. The figure below shows a frustrum

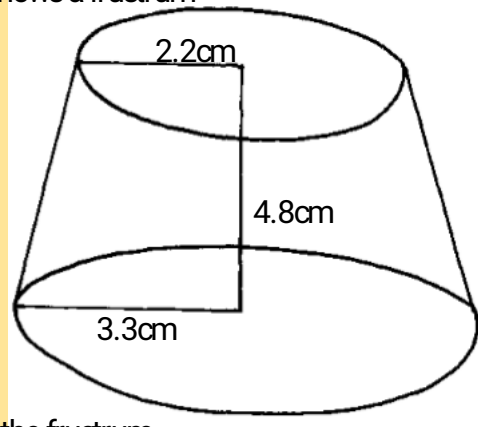

Find the volume of the frustrum

11. The diagram below shows a metal solid consisting of a cone mounted on hemisphere. The height of the cone is  $1\frac{1}{2}$  times its radius;

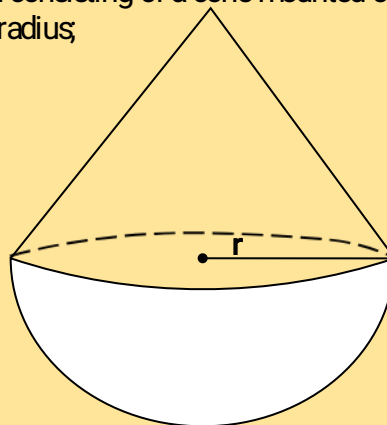

Given that the volume of the solid is  $31.5\pi \text{ cm}^3$ , find:

- The radius of the cone
  - The surface area of the solid
  - How much water will rise if the solid is immersed totally in a cylindrical container which contains some water, given the radius of the cylinder is 4 cm
  - The density, in  $\text{kg/m}^3$  of the solid given that the mass of the solid is 144 gm
12. A solid metal sphere of volume  $1280 \text{ cm}^3$  is melted down and recast into 20 equal solid cubes. Find the length of the side of each cube.
13. The figure below shows a frustrum cut from a cone

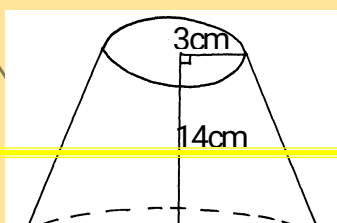

Calculate the volume of the frustrum

### 33. Quadratic equations

1. In a triangle ABC, angle B is  $90^\circ$ . Find the value of x and hence the area of the triangle

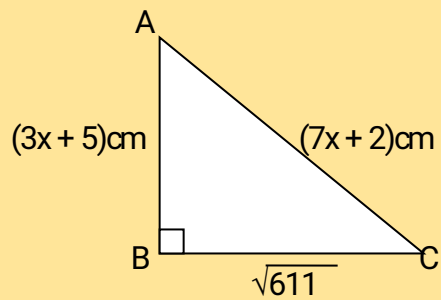

2. Solve the following inequalities and represent the solution on a number line hence state the integral values  $7x - 4 \leq 9x + 2 < 3x + 14$

### 34. Linear inequalities

- Find without using a calculator, the value of :  

$$\frac{12\sqrt{0.0625} - 12.4 \div 0.4 \times 3}{\sqrt[3]{8} \text{ of } 2.56 + 8.68}$$
- Solve and write down all the integral values satisfying the inequality.  
 $X - 9 \leq -4 < 3x - 4$
- Solve the inequality and show the solution on the number line.  
 $3 - 2x < x < 2x + 5$
- Show on a number line the range of all integral values of  $x$  which satisfy the following pair of inequalities:  
 $3 - x \leq 1 - \frac{1}{2}x$   
 $-\frac{1}{2}(x-5) \leq 7 - x$
- Solve the inequalities  $4x - 3 \leq 6x - 1 < 3x + 8$ ; hence represent your solution on a number line
- Find all the integral values of  $x$  which satisfy the inequalities  
 $2(2-x) < 4x - 9 < x + 11$
- Find the inequalities that define the unshaded region

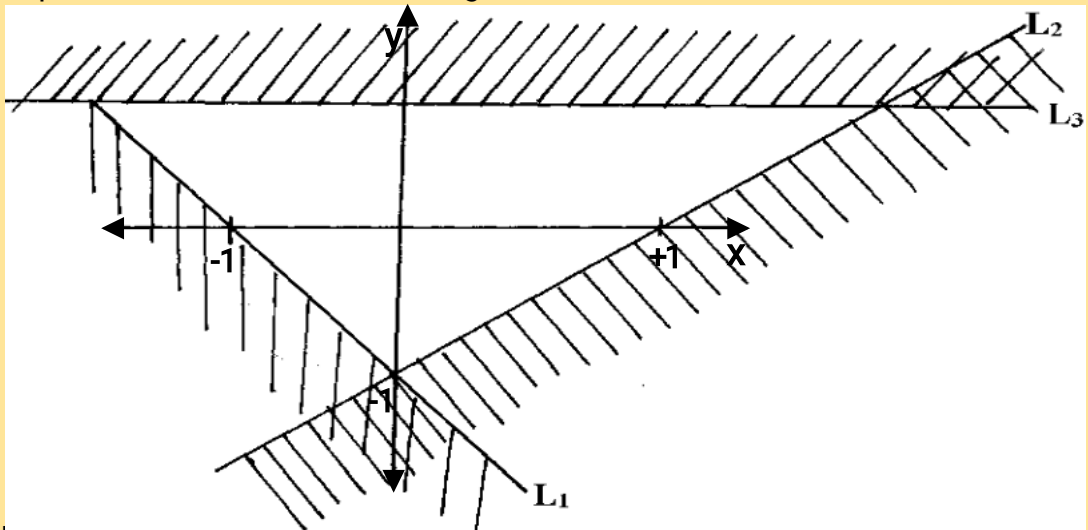

- Given that  $x + y = 8$  and  $x^2 + y^2 = 34$   
 Find the value of:-  
 a)  $x^2 + 2xy + y^2$   
 b)  $2xy$
- Find the inequalities satisfied by the region labelled R

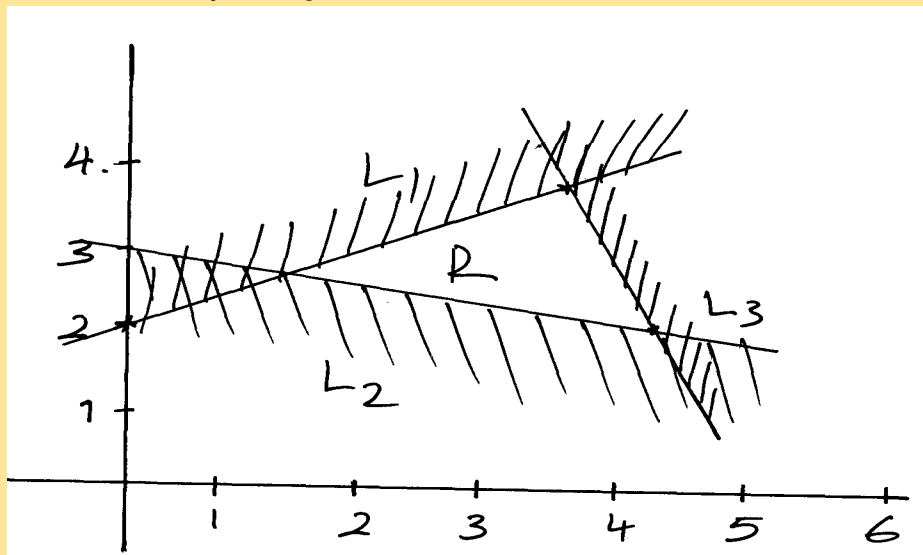

- The region R is defined by  $x \geq 0$ ,  $y \geq -2$ ,  $2y + x \leq 2$ . By drawing suitable straight line on a sketch, show and label the region R

11. Find all the integral values of  $x$  which satisfy the inequality  $3(1+x) < 5x - 11 < x + 45$
12. The vertices of the unshaded region in the figure below are  $O(0, 0)$ ,  $B(8, 8)$  and  $A(8, 0)$ . Write down the inequalities which satisfy the unshaded region

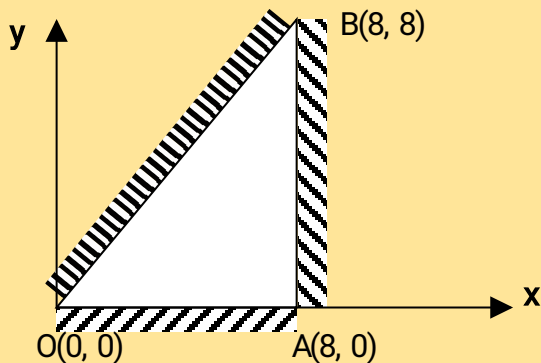

### 35. Angle Properties of Circles

1. Two circles of radii 4cm and 6cm intersect as shown below. If angle  $XPY = 30^\circ$  and angle  $XAY = 97.2^\circ$ . Find the area of the shaded part. (Take  $\pi = \frac{22}{7}$ )

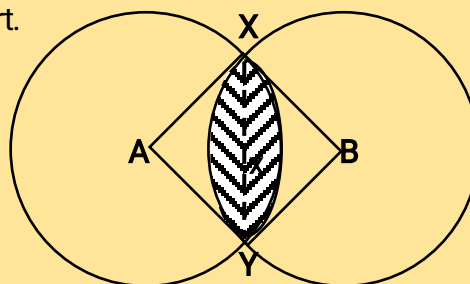

2. In the diagram,  $O$  is the centre of the circle and  $AD$  is parallel to  $BC$ . If angle  $ACB = 50^\circ$  and angle  $ACD = 20^\circ$ .

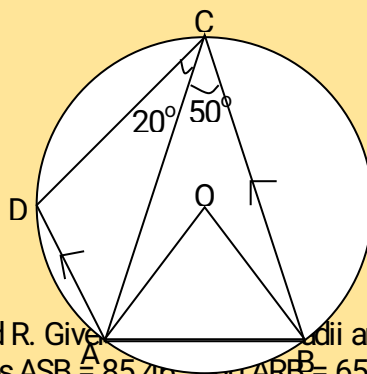

Calculate; (i)  $\angle OAB$   
(ii)  $\angle ADC$

3. Two intersecting circles have centres  $S$  and  $R$ . Given their radii are 28cm and 35cm, their common chord  $AB = 38$ cm and angles  $ASB = 85.46^\circ$  and  $ARB = 65.76^\circ$ ,

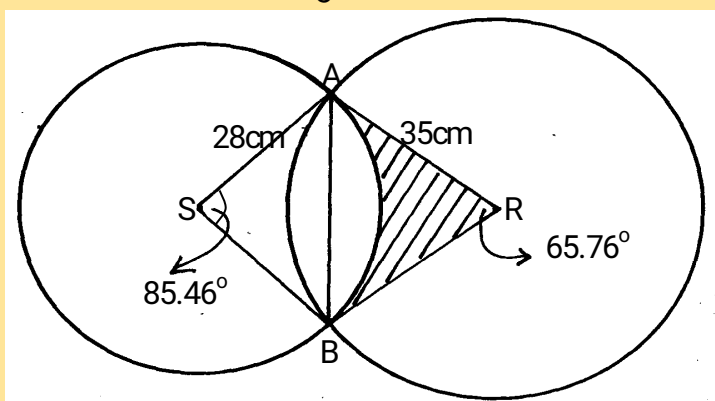

Calculate the shaded area

4. In the figure below ABCD is a cyclic quadrilateral in which  $AD = DC$  and AB is parallel to CD. Given that angle  $ABC = 80^\circ$ , Find the size of:

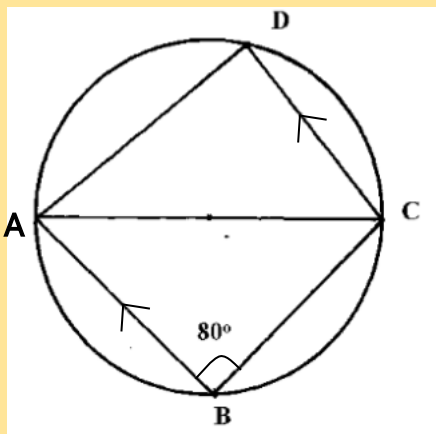

a)  $\angle DAC$

b)  $\angle BAC$

c)  $\angle BCD$

5. Line  $QR = 6.5\text{cm}$  is given below.-(*Do not use a protractor for this question*)

(a) Draw triangle PQR such that P lies above line QR,  $\angle PQR = 30^\circ$  and  $PQ = 7\text{cm}$

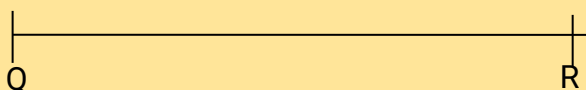

(b) By accurate construction on the diagram above, show the locus of a point which lies within the triangle such that:-

(i) T is more than 2.5cm from line PQ  
and

(ii) T is not more than 4.5cm from Q  
Shade the region in which T lies

(c) Lines QP and QR are produced to K and M respectively

(i) Show by construction on the diagram above, the locus of a point C which is equidistant from each of the lines PK, PR and RM

(ii) With centre C and an appropriate radius, draw a circle to touch each of the lines PK, PR and RM only once  
Measure the radius

What name is given to the circle drawn in (c) (ii) with respect to triangle QPR

6. The figure below shows a circle centre O and a cyclic quadrilateral ABCD.  $AC = CD$ , angle  $ACD$  is  $80^\circ$  and BOD is a straight line. Giving reasons for your answer, find the size of :-

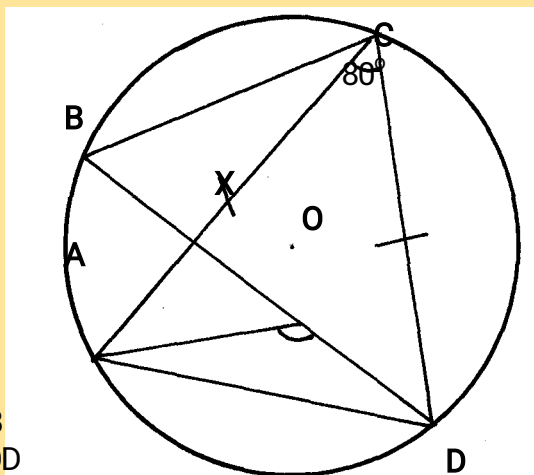

- (i) Angle ACB  
(ii) Angle AOD

- (iii) Angle CAB
- (iv) Angle ABC
- (v) Angle AXB

7. The figure below shows two circles of equal radius of 9 cm with centres A and B. Angle CAD =  $80^\circ$

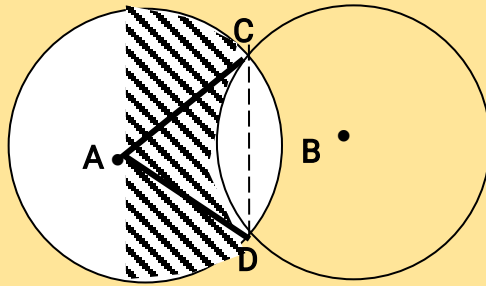

- a) Calculate the area of:-
- i) The sector CAD.
  - ii) The triangle CAD.
  - iii) The shaded region.

8. In the diagram below,  $\angle QOT$  is a diameter.  $\angle QTP = 48^\circ$ ,  $\angle TQR = 46^\circ$  and  $\angle SRT = 37^\circ$

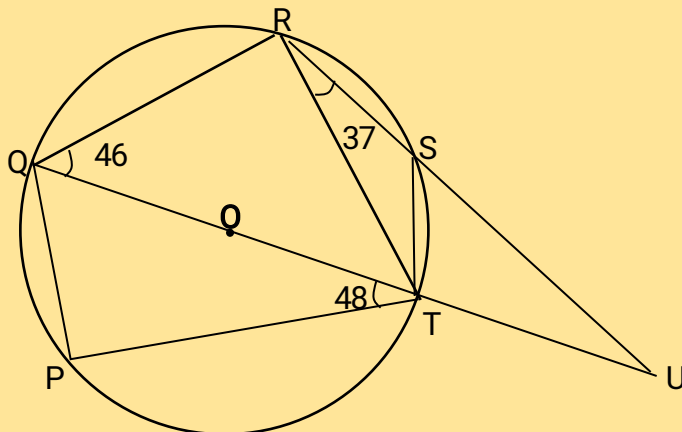

Calculate, giving reasons in each case:-

- (a)  $\angle RST$
  - (b)  $\angle SUT$
  - (c)  $\angle ROT$
  - (d)  $\angle PST$
  - (e) Reflex  $\angle SOP$
9. The diagram below shows a circle with a chord  $PQ = 3.4\text{cm}$  and angle  $\angle PRQ = 40^\circ$ . Calculate the area of the shaded segment.

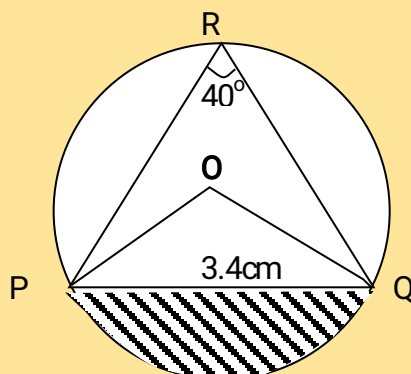



10. The figure below shows circle ABCD. The line EDF is a tangent to the circle at D.  $\angle ADF = 70^\circ$ ,  $\angle FAD = 65^\circ$  and  $\angle CDE = 35^\circ$

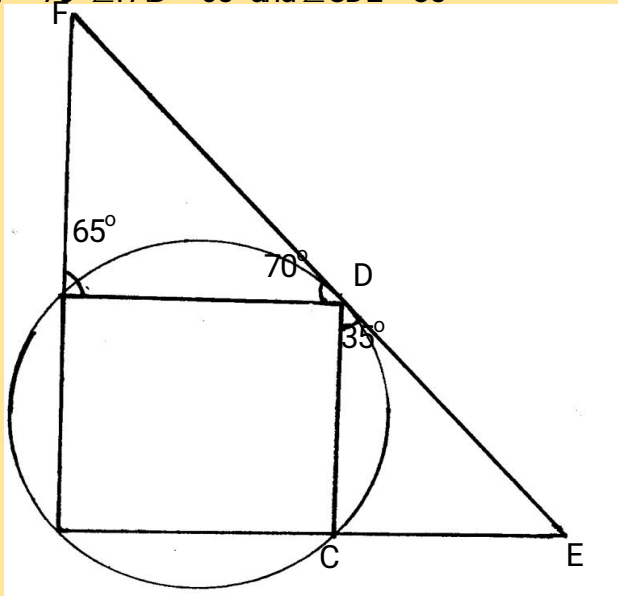

Find the values of the following angles, stating your reasons in each case

- $\angle ABC$
  - $\angle BCD$
  - $\angle DCE$
  - $\angle ACD$
10. In the figure below BD is the diameter of the circle and O is the centre.

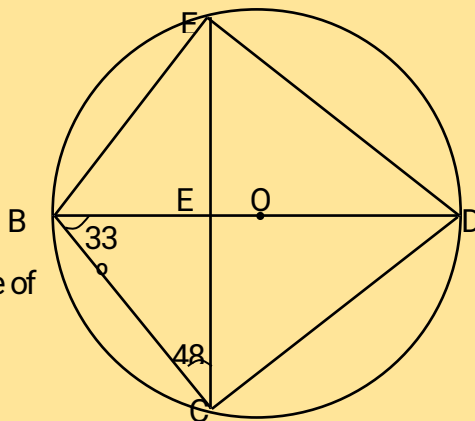

Find the size of

- $\angle ADC$
- $\angle AEB$

### 36. Vectors

1. Given that  $4p - 3q = \begin{pmatrix} 10 \\ 5 \end{pmatrix}$  and  $p + 2q = \begin{pmatrix} -14 \\ 15 \end{pmatrix}$  find

a) (i)  $\underline{p}$  and  $\underline{q}$

(3 mks)

(iv)  $|\underline{p + 2q}|$

(3 mks)

(b) Show that A (1, -1), B (3, 5) and C (5, 11) are collinear

(4 mks)

1. The position vectors of points x and y are  $x = 2i + j - 3k$  and  $y = 3i + 2j - 2k$  respectively. Find  $x \cdot y$  as a column vector (2 mks)

1. Express in surds form and rationalize the denominator.

$$\frac{1}{\sin 60^\circ \sin 45^\circ - \sin 45^\circ}$$

2. If  $\vec{OA} = 12i + 8j$  and  $\vec{OB} = 16i + 4j$ . Find the coordinates of the point which divides  $\vec{AB}$  internally in the ratio 1:3
3. Find scalars  $m$  and  $n$  such that

$$m \begin{pmatrix} 4 \\ 3 \end{pmatrix} + n \begin{pmatrix} 3 \\ 2 \end{pmatrix} = \begin{pmatrix} 5 \\ 8 \end{pmatrix}$$

4. In a triangle OAB, M and N are points on OA and OB respectively, such that  $OM:MA = 2:3$  and  $ON:NB = 2:1$ .  $\vec{AN}$  and  $\vec{BM}$  intersect at X. Given that  $OA = a$  and  $OB = b$

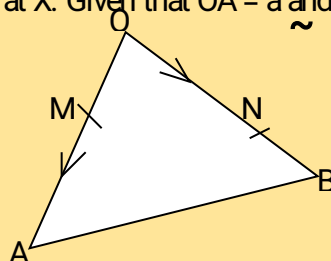

- (a) Express in terms of  $a$  and  $b$
- (i)  $\vec{BM}$
- (ii)  $\vec{AN}$
- (b) By taking  $\vec{BX} = t$  and  $\vec{AX} = h \vec{AN}$ , where  $t$  and  $h$  are scalars, express  $\vec{OX}$  in two different ways
- (c) Find the values of the scalars  $t$  and  $h$
- (d) Determine the ratios in which  $X$  divides :-
- (i)  $\vec{BM}$
- (ii)  $\vec{AN}$

5. OABC is a parallelogram, M is the mid-point of OA and  $\vec{AX} = \frac{2}{7} \vec{AC}$ ,  $OA = a$  and  $OC = c$

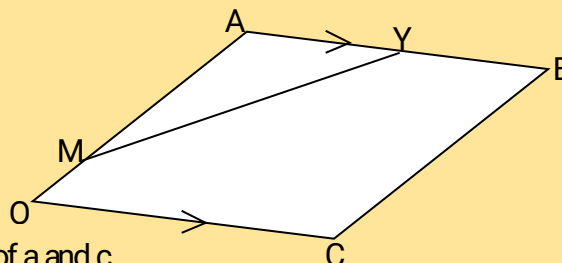

- (a) Express the following in terms of  $a$  and  $c$
- (i)  $\vec{MA}$
- (ii)  $\vec{AB}$
- (iii)  $\vec{AC}$
- (iv)  $\vec{AX}$
- (b) Using triangle MAX, express  $\vec{MX}$  in terms of  $a$  and  $c$
- (c) The co-ordinates of A and B are (1, 6, 8) and (3, 0, 4) respectively. If O is the origin and P the midpoint of AB. Find;
- (i) Length of OP

(ii) How far are the midpoints of OA and OB?

6. a) If A, B & C are the points (2, -4), (4, 0) and (1, 6) respectively, use the vector method to find the coordinates of point D given that ABCD is a parallelogram  
 b) The position vectors of points P and Q are  $\vec{p}$  and  $\vec{q}$  respectively. R is another point with position vector  $\vec{r} = \frac{3}{2}\vec{q} - \frac{1}{2}\vec{p}$ . Express in terms of  $\vec{p}$  and  $\vec{q}$   
 (i)  $\vec{PR}$   
 (ii)  $\vec{PQ}$ , hence show that P, Q & R are collinear.  
 (iii) Determine the ratio PQ : QR

7. The figure shows a triangle of vectors in which OS: SP = 1:3, PR:RQ = 2:1 and T is the midpoint of OR

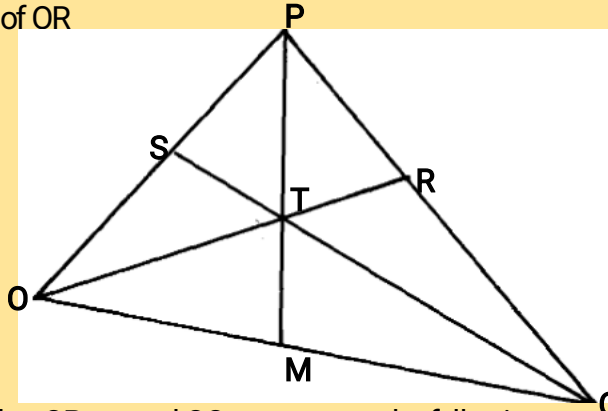

- a) Given that  $\vec{OP} = \vec{p}$  and  $\vec{OQ} = \vec{q}$ , express the following vectors in terms of  $\vec{p}$  and  $\vec{q}$   
 i)  $\vec{OR}$   
 ii)  $\vec{QT}$   
 b) Express  $\vec{TS}$  in terms of  $\vec{p}$  and  $\vec{q}$  and hence show that the points Q, T and S are collinear  
 c) M is a point on OQ such that  $OM = KOQ$  and PTM is a straight line. Given that  $PT:TM = 5:1$ , find the value of k

8. Given that  $\vec{a} = \begin{pmatrix} 1 \\ 2 \\ 3 \end{pmatrix}$ ,  $\vec{b} = \begin{pmatrix} 2 \\ 1 \\ 4 \end{pmatrix}$  and  $\vec{c} = \begin{pmatrix} 3 \\ 4 \\ 1 \end{pmatrix}$  and that  $\vec{p} = 3\vec{q} - \frac{1}{2}\vec{b} + \frac{1}{10}\vec{c}$   
 Express  $\vec{p}$  as a column vector and hence calculate its magnitude  $|\vec{p}|$  correct to two decimal places

9. In a triangle OAB, M and N are points on OA and OB respectively, such that  $OM:MA = 2:3$  and  $ON:NB = 2:1$ . AN and BM intersect at X. Given that  $\vec{OA} = \vec{a}$  and  $\vec{OB} = \vec{b}$

- (a) Express in terms of  $\vec{a}$  and  $\vec{b}$ :  
 (i)  $\vec{BM}$   
 (ii)  $\vec{AN}$   
 (b) Taking  $\vec{BX} = k\vec{BM}$  and  $\vec{AX} = h\vec{AN}$  where k and h are constants express  $\vec{OX}$  in terms of  
 (i)  $\vec{a}$ ,  $\vec{b}$  and k only  
 (ii)  $\vec{a}$ ,  $\vec{b}$ , and h only  
 (c) Use the expressions in (b) above to find values of k and h

10. In the figure below OAB is a triangle in which M divides OA in the ratio 2:3 and N divides OB in the ratio 4:1. AN and BM intersect at X

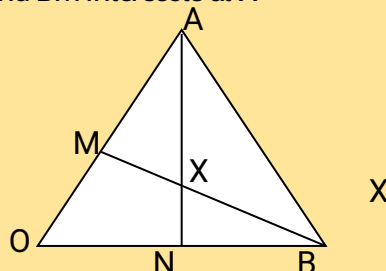

- (a) Given that  $\vec{OA} = \vec{a}$  and  $\vec{OB} = \vec{b}$ , express in terms of  $\vec{a}$  and  $\vec{b}$   
 (i)  $\vec{AN}$   
 (ii)  $\vec{BM}$

(iii)  $\vec{AB}$

(b) If  $\vec{AX} = s\vec{AN}$  and  $\vec{BX} = t\vec{BM}$ , where  $s$  and  $t$  are constants, write two expressions for  $\vec{OX}$  in terms of  $\vec{a}$ ,  $\vec{b}$ ,  $s$  and  $t$ . Find the value of  $s$  and  $t$  hence write  $\vec{OX}$  in terms of  $\vec{a}$  and  $\vec{b}$

11. A student traveling abroad for further studies sets aside Kshs. 115800 to be converted into US dollars through a bank at the rate of 76.84 per dollar. The bank charges a commission of  $2\frac{1}{2}\%$  of the amount exchanged. If he plans to purchase text books and stationery worth US\$270, how much money, to the nearest dollar, will he be left with?

12. Given that:  $\vec{r} = 5\vec{i} - 2\vec{j}$  and  $\vec{m} = -2\vec{i} + 6\vec{j} - \vec{k}$  are the position vectors for R and M respectively. Find the length of vector  $\vec{RM}$

13. OABC is a trapezium in which  $OA = \vec{a}$  and  $AB = \vec{b}$ .  $AB$  is parallel to  $OC$  with  $2AB = OC$ . T is a point on  $OC$  produced so that  $OC:CT = 2:1$ .  $AT$  and  $BC$  intersect at  $X$  so that  $\vec{BX} = h\vec{BC}$  and  $\vec{AX} = k\vec{AT}$

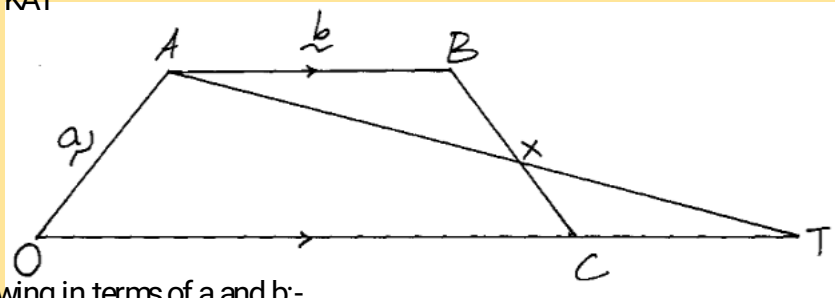

(a) Express the following in terms of  $\vec{a}$  and  $\vec{b}$ :-

(i)  $\vec{OB}$

(ii)  $\vec{BC}$

(b) Express  $\vec{CX}$  in terms of  $\vec{a}$ ,  $\vec{b}$  and  $h$

(c) Express  $\vec{CX}$  in terms of  $\vec{a}$ ,  $\vec{b}$  and  $k$

(d) Hence calculate the values of  $h$  and  $k$

14. Given that  $\vec{a} = 2\vec{i} + \vec{j} - 2\vec{k}$  and  $\vec{b} = -3\vec{i} + 4\vec{j} - \vec{k}$  find:-  
 $|\vec{a} + \vec{b}|$ .

15. In the figure below, E is the mid-point of  $BC$ .  $AD:DC = 3:2$  and F is the meeting point of  $BD$  and  $AE$

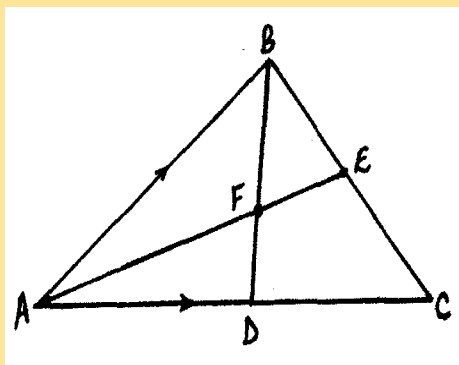

If  $\vec{AB} = \vec{b}$  and  $\vec{AC} = \vec{c}$

(i) Express  $\vec{BD}$  and  $\vec{AE}$  in terms of  $\vec{b}$  and  $\vec{c}$

(ii) If  $\mathbf{BF} = t\mathbf{BD}$  and  $\mathbf{AF} = n\mathbf{AE}$ , find the values of  $t$  and  $n$

(iii) State the ratios in which  $F$  divides  $\mathbf{BD}$  and  $\mathbf{AE}$

16. The coordinates of point  $O$ ,  $A$ ,  $B$  and  $C$  are  $(0, 0)$ ,  $(3, 4)$ ,  $(11, 6)$  and  $(8, 2)$  respectively.

A point  $P$  is such that the vector  $\mathbf{OP}$ ,  $\mathbf{BA}$ ,  $\mathbf{BC}$  satisfy the vector equation  $\mathbf{OP} = \mathbf{BA} + \frac{1}{2}\mathbf{BC}$

Find the coordinates of  $P$

17. A point  $Q$  divides  $AB$  in the ratio  $7:2$ . Given that  $A$  is  $(-3, 4)$  and  $B(2, -1)$ .

Find the co-ordinates of  $Q$

### 37. Representation of data

1. Below is a histogram, draw.

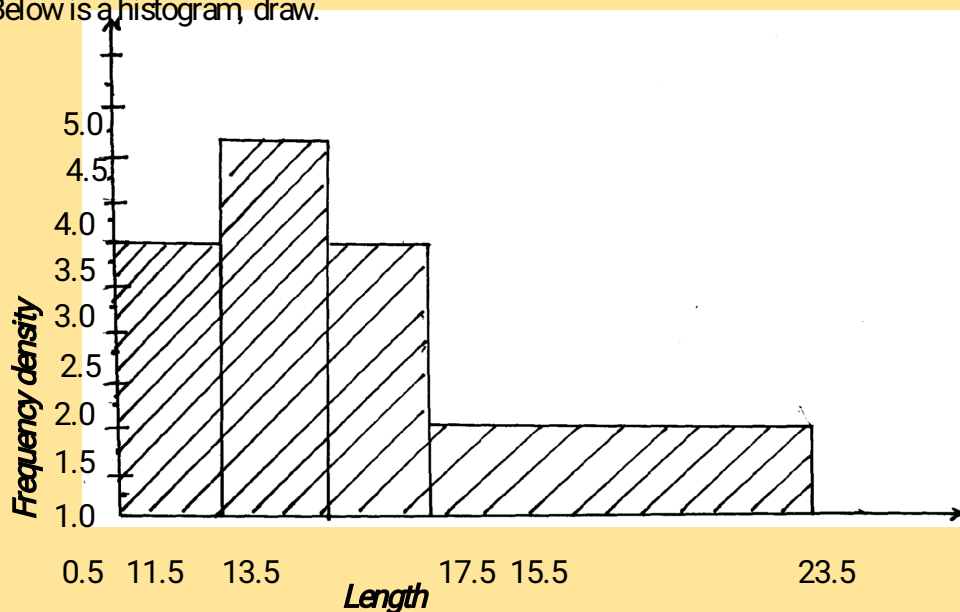

Use the histogram above to complete the frequency table below.

Length	Frequency
$11.5 \leq x \leq 13.5$	
$13.5 \leq x \leq 15.5$	
$15.5 \leq x \leq 17.5$	
$17.5 \leq x \leq 23.5$	

2. Wambui salary as follows:

spent her

Food	40%
Transport	10%
Education	20%
Clothing	20%
Rent	10%

Draw a pie chart to represent the above information

2. The examination marks in a mathematics test for 60 students were as follows:-

60	54	34	83	52	74	61	27	65	22
70	71	47	60	63	59	58	46	39	35
69	42	53	74	92	27	39	41	49	54
25	51	71	59	68	73	90	88	93	85
46	82	58	85	61	69	24	40	88	34
30	26	17	15	80	90	65	55	69	89
Class	Tally			Frequency		Upper class limit			
10-29									
30-39									
40-69									
70-74									
75-89									
90-99									

From the table;

(a) State the modal class

(b) On the grid provided, draw a histogram to represent the above information

4. The marks scored by 200 from 4 students of a school were recorded as in the table below.

<b>Marks</b>	41 – 50	51 – 55	56 – 65	66 – 70	71 – 85
<b>Frequency</b>	21	62	55	50	12

- (a) On the graph paper provided, draw a histogram to represent this information.
- (b) On the same diagram, construct a frequency polygon.
- (c) Use your histogram to estimate the modal mark.

5. The diagram below shows a histogram representing the marks obtained in a certain test:-

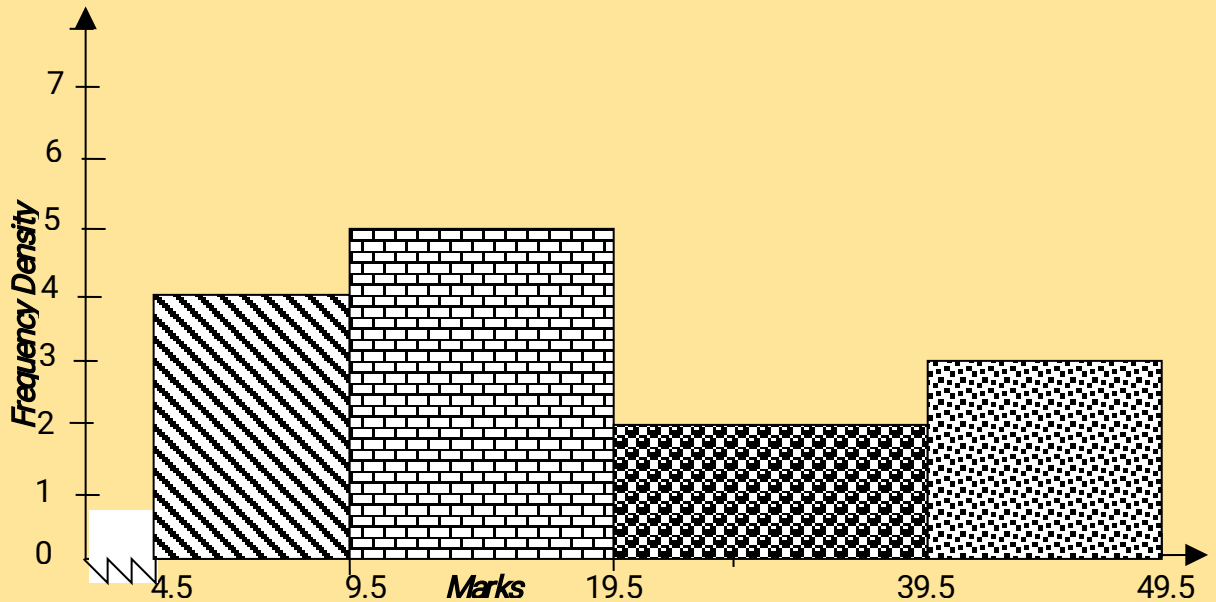

- (a) If the frequency of the first class is 20, prepare a frequency distribution table for the data
- (b) State the modal class
- (c) Estimate:
  - (i) The mean mark
  - (ii) The median mark

6. The data below shows the number of sessions different subjects are taught in a week.

Draw a pie chart to show the data:

Subject	Eng	Maths	Chemistry	C.R.E
No. of sessions	8	7	4	3

7. The height of 50 athletes in Moi University team were shown below:

Height (cm)	150-159	160-169	170-179	180-189	190-199	200-209
Frequency	2	9	12	16	7	4

- i) State the modal class
- ii) Calculate the median height of the athletes

8. The table below shows the length of 40 mango tree leaves;

Length (mm)	Frequency	Cumulative frequency
118-126	3	3
127-135	4	7
136-144	10	17
145-153	12	29
154-162	5	34
163-171	4	38
172-180	2	40

- (a) Determine the;  
(i) Modal class  
(ii) Median class
- (b) Calculate;  
(i) the mean of the leaves  
(ii) the median of the leaves

### 38. Measures of central tendency

1. The results of a mathematics test that a hundred students took are as shown below:-

Marks	No. of students
30-34	4
35-39	6
40-44	10
45-49	14
50-54	<b>X</b>
55-59	24
60-64	14
65-69	6

- (a) Determine (i) the value of **X**  
(ii) The modal class
- (b) Calculate the mean
- (c) The median
2. Without using logarithms or calculator evaluate:  
 $2\log_{10}5 - 3\log_{10}2 + \log_{10}32$
3. The table below shows heights of 50 students :-

Height (cm)	Frequency
140-144	3
145-149	15
150-154	19
155-159	11
160-164	2

- (a) State the modal class
- (b) Calculate the median height





4. In an experiment, the height of 100 seedlings were measured to the nearest centimeter and the results were recorded as shown below,

Height (cm)	20-24	25-29	30-34	35-39	40-44	45-49
Frequency	3	19	25	20	18	15

Calculate the median height

5. Given that  $x = -4$  is a root of the equation  $2x^2 + 6x - 2k = 0$ ; Find;  
 (a) the value of  $k$   
 (b) the second root

Marks	60 – 62	63 – 68	69 – 73	74 – 80
Frequency	10	20	40	15

7. The table below shows the distribution of marks obtained by some candidates in a mathematics test

Marks	30-39	40-49	50-59	60-69	70-79	80-89	90-99
No. of candidates	2	3	10	12	8	3	2
c.f							

- a) state the total number of candidates who sat the test  
 b) state the modal class  
 c) calculate the mean mark using an assumed mean of 64.5 marks  
 d) calculate the median mark

8. Find these statistics of the following data 4, 2, 2, 6, 1, 3, 4, 1, 4  
 a) Mode  
 b) Median  
 c) Mean

9. (a) The marks scored by a group of form two students in a mathematical test were as recorded in the table below:-

Marks	0-9	10-19	20-29	30-39	40-49	50-59	60-69	70-79	80-89	90-99
Frequency	1	2	4	7	10	16	20	6	3	1

- (a) (i) State the modal class  
 (ii) Determine the class in which the median mark lies  
 (iii) Using an assumed mean of 54.5, calculate the mean mark

10. Six weeks after planting, the height of maize plants were measured correct to the nearest centimeter. The frequency distribution is given in the table below.

Height ( $x$ )	$0 \leq x < 4$	$4 \leq x < 8$	$8 \leq x < 12$	$12 \leq x < 16$	$16 \leq x < 20$
Frequency	3	8	19	14	6

Estimate the median height of the plants

11. Below are marks scored by student in maths talk in science congress.

Marks	1 - 5	6 – 15	16 – 20	21 – 35	36 – 40	41 – 50
No. of students	1	3	6	12	5	3

Draw a histogram from the table above.



### 39. Linear motion

- Two motorists Kinyua and Nyaboke travelled between two towns K and M which are 580km apart. Kinyua started from K at 6.20 a.m and traveled towards M at 90km/hr. Nyaboke started from town M  $1\frac{2}{3}$  hours later and traveled towards town K at an average speed of 120km/h. At a small shopping centre along the way, Kinyua had a snack and car check for 20 minutes before proceeding
  - (i) How far from town M did they meet?  
(ii) At what time did they meet?
  - A rally driver starts from town M going to town k at 9.30a.m. If he averages 180km/hr, Calculate the distance from K and the time when the rally driver overtook Nyaboke
- The distance between two towns A and B is 150km. A car starts from town A at 10.00a.m and travels at an average speed of 80km/h towards B. A transit lorry travels from B at 10:15a.m towards town A at an average speed of 40km/h. At what time will the two vehicles meet?
- The diagram below shows the speed-time graph for a bus traveling between two towns. The bus starts from rest and accelerates uniformly for 50seconds. It then travels at a constant speed for 150seconds and finally decelerates uniformly for 100seconds.

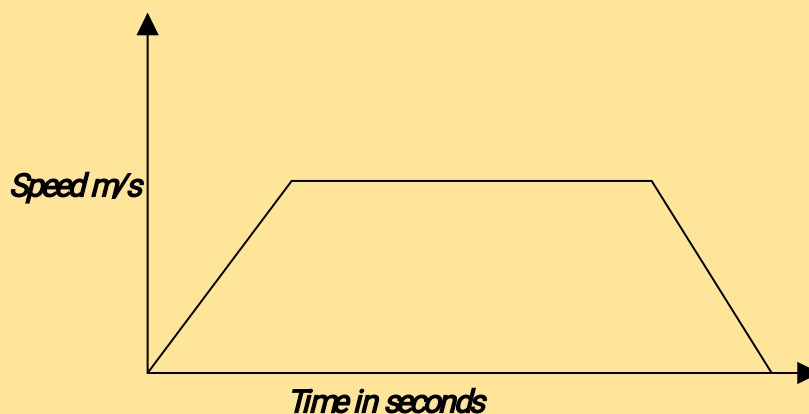

- Given that the distance between the two towns is 2700m, calculate the ;
- maximum speed in km/h, the bus attained
  - acceleration
  - distance the bus traveled during the last 50seconds
  - time the bus takes to travel the first half of the journey
- A cyclist covers a distance of 45 kilometres at a speed of 10km/h and a further 45 kilometres at 15km/h. Find his average speed for the journey
  - A lorry left town A for town B  $1\frac{1}{4}$  hours before a car. The lorry and the car are traveling in the same direction at  $80\text{kmh}^{-1}$  and  $120\text{kmh}^{-1}$  respectively. After the overtake, the car moved for  $\frac{199}{800}$  another hours before reaching town B. Calculate:
    - The time the car took before overtaking the lorry completely
    - The distance between the two towns
    - The time the lorry will take to reach town B after the arrival of the car
  - A country bus left Nairobi at 10.45a.m and traveled towards Mombasa at an average speed of 60km/h. A matatu left Nairobi at 1:15p.m on the same day and traveled along the same road at an average speed of 100km/h. The distance between Nairobi and Mombasa is 500km.

- (a) Determine the time of the day when the matatu overtook the bus  
 (b) Both vehicles continue towards Mombasa at their original speeds. How long had the matatu waited before the bus arrived?
7. Two passenger trains **A** and **B** which are 240m apart are travelling at 164km/h and 88km/h respectively approach on another one a straight railway line. Train **A** is 150m long and train **B** is 100m long. Determine the time in seconds that elapses before the two trains completely pass each other
8. A bus 5m long completely overtakes a trailer 15m long travelling in the same direction in 4.8 seconds. If the speed of the bus is 40 km/hr, determine the speed of the trailer in km/hr.
9. Find the LCM and GCD of the following numbers:  $2 \times 3 \times 5^3$  and  $2^4 \times 3^2 \times 5^2$ .
10. A boat sails from a point A to a point B upstream, a distance of 30 km and back to A in 3hrs 12 min. The current in the river is flowing at 5km/hr. Determine the speed of the boat in still water.
- 11.. Two friends Ojwang and David live 40 km apart. One day Ojwang left his house at 9.00 a.m and cycled towards David's house at an average speed of 15 km/h. David left his house at 10.30 a.m. on the same day and cycled towards Ojwang's house at an average speed of 25 km/h.
- a) Determine ;  
 (i) The distance from Ojwang's house, where the two friends met.  
 (ii) The time they met.  
 (iii) How far Ojwang was from David's house when they met.
- b) The two friends took 10 minutes at the meeting point and they cycled to David's house at an average speed of 12 km/h. Find the time they arrived at David's house.
12. Mr. Kamau left town **S** at 6.00a.m and travels at an average speed of 24km/hr towards **R**. Mrs. Ronoh left town **R** to town **S** 10minutes later and arrived at 7.00a.m. If distance **RS** = 42km, find;  
 (a) Where and when they will meet  
 (b) The time Kamau arrived at **R**  
 (c) If at 7.00a.m another traveler left **S** and travels towards **R** at speed twice that of Mrs. Ronoh, find where and when Mr. Kamau was overtaken by the traveler if so
13. A train 100m long travelling at 72km/hr, overtakes another train traveling in the same direction at 56km/hr and passes it completely in 54 seconds.
- i) Find the length of the second train  
 ii) Find also the time they would have taken to pass one another if they had been traveling at these speeds in opposite directions
14. An unskilled worker may either walk to work along a route 5km to take a bus journey of 7km. The average speed of the bus is 24km/hr faster than his average speed. Taking the average walking speed as  $x$  km/hr;
- (a) Write down expressions for time of the journey;  
 (i) When walking  
 (ii) When using the bus  
 (b) The journey by bus takes 36 minutes less than the journey on foot, find his walking speed

(c) Hence find the time he takes to talk to work

15. At 1.50 p.m. a matatu is traveling at 80 km/h and it is 40 km behind a motorcycle traveling at 60 km/h.  
 (a) After how long will the matatu overtake the motorcycle?  
 (b) At what time will the matatu overtake the motorcycle?
16. A bus left Nairobi at 8:00a.m and traveled towards Kisumu at an average speed of 80km/h. At 8.30a.m, a car left Kisumu towards Nairobi at an average speed of 120km/hr. Given that the distance between Nairobi and Kisumu is 400km, Calculate:-  
 (a) The time the car arrived in Nairobi  
 (b) The time the two vehicles met  
 (c) The distance from Nairobi to the meeting point  
 (d) The distance of the bus from Kisumu when the car arrived in Nairobi
17. Two trucks A and B travelling at 28km/hr and 26km/hr respectively approach one another on a straight road. Truck A is 10m long, while truck B is 15m long. Determine the time in seconds that elapses before the trucks completely pass each other

## 40. Quadratic expressions and equation 2

1. Complete the table below for the function  $y = 2x^3 + 5x^2 - x - 6$  (2 mks)

x	-4	-3	-2	-1	0	1	2
$2x^3$	-128	-54			0	2	16
$5x^2$	80	45	20	5	0	5	20
-x	4	3			0	-1	
-6	-6	-6	-6	-6	-6	-6	-6
y	-50				-6	0	

(b) On

the grid provided draw the graph  $y = 2x^3 + 5x^2 - x - 6$  for  $-4 \leq x \leq 2$ . Use 2cm to represent 1 unit on the x-axis and 1 cm to represent 5 units on the y – axis (4 mks)

(c) By drawing a suitable line, use the graph in (b) to solve the

i. equation  $2x^3 + 5x^2 + x - 4 = 0$  (2 mks)

ii. equation  $2x^3 + 5x^2 - x + 2 = 0$  (2 mks)

1. (a) Use a convenient scale to draw the graph of  $y = -x^2 + 5x - 3$  for the range  $-2 \leq x \leq 6$   
 (b) Use your graph to determine the roots of the equation  $5x - x^2 - 3 = 0$

(c) Use your graph to solve the equation  $2x - x^2 + 3 = 0$  by drawing a suitable straight line

2. Find a quadratic equation whose roots are  $2.5 + 3\sqrt{5}$  and  $2.5 - 3\sqrt{5}$  expressing it in the form

$$ax^2 + bx + c = 0 \quad \text{Where } a, b \text{ and } c \text{ are integers}$$

3. Find the products of 17.3 and 13.8. Find also the percentage error in getting the product.

4. (a) Complete the table below for the equation :-  $y = x^2 + 3x - 6$  for  $-6 \leq x \leq 4$

x	-6	-5	-4	-3	-2	-1	0	1	2	3	4
y	12			-6			-6				22

(b) Using a scale 1cm to represent 2 units in both axes. Draw the graph of  $y = x^2 + 3x - 6$

(c) Use your graph to solve:-

(i)  $X^2 + 3X = 6$

(ii)  $X^2 + 3X - 2 = 0$

5. (a) Complete the table for the function:  $y = 2x^2 + 3x + 1$

x	-4	-3	-2	-1	0	1	2	3
$2x^2$		18			0			18
$3x+1$		-7			0			10
y		11			1	6		

(b) Use the table in (a) above to draw the graph :-  $y = 2x^2 + 3x + 1$  for  $-4 \leq x \leq 3$

(c) Use the graph in (b) to solve the equation :-

(i)  $2x^2 + 4x - 3 = 0$

(ii)  $x^2 + \frac{3x}{2} + 2 = 3$

6. A youth group decided to raise Ksh 480,000 to buy a piece of land costing Ksh. 80,000 per hectare. Before the actual payment was made, four of the members pulled out and each of those remaining had to pay an additional Kshs. 20,000.
- (a) If the original number of the group members was  $x$ , write down;
- An expression of how much each was to contribute originally.
  - An expression of how the remaining members were to contribute after the four pulled out.
- (b) Determine the number of members who actually contributed towards the purchase of the land.
- (c) Calculate the ratio of the supposed original contribution to the new contribution.
- (d) If the land was sub-divided equally, find the size of land each member got. (2 mk)
7. a) Draw the graph of  $y = 2x^2 + x - 2$  given the range  $-3 \leq x \leq 2$   
 b) Use your graph above to solve
- $2x^2 + x - 2 = 0$
  - $2x^2 + x - 3 = 0$
  - $2x^2 + x - 5 = 0$
8. Three planes **A**, **B** and **C** leave an airport **P** simultaneously at 9.30a.m. Plane **A** flies on a bearing of  $070^\circ$  from **P** at a speed of 400km/h. Plane **B** flies on a bearing of  $290^\circ$  at a speed of 500km/h. Plane **C** flies on a bearing of  $162^\circ$  from **P** at a speed of 300km/h.  
*(Use scale drawing for this question)*
- (a) Show by scale drawing, the relative positions of the 3 planes **A**, **B** and **C** three hours after leaving airport **P**. (Use scale 1 cm represents 200km)
- (b) After 3 hours, **B** turns and head straight to the current position of **A** at the same speed it had. Determine the scale drawing, the time it takes to reach this point, to the nearest minute
- (c) Determine the bearing and distance of **B** from **C** after the first 3 hours of flight after leaving **P**
9. a) Use trapezoidal rule to find the area between the curve  $y = x^2 + 4x + 4$ , the  $x$ - axis and the co-ordinates  $x = -2$  and  $x = 1$ . Take values of  $x$  at intervals of  $\frac{1}{2}$  unit.  
 b) Use integration to find the exact area. Hence find the percentage error in your approximation.
10. a) Use trapezoidal rule to find the area between the curve  $y = x^2 + 4x + 4$ , the  $x$ - axis and the co-ordinates  $x = -2$  and  $x = 1$ . Take values of  $x$  at intervals of  $\frac{1}{2}$  unit.  
 b) Use integration to find the exact area. Hence find the percentage error in your approximation.
11. Draw the graph of  $y = 2x^2 - 4x - 5$  for  $x$  between -3 and 5 on the grid provided
- (a) State the line of symmetry for the graph  
 (b) State the range of values for which  $2x^2 - 4x - 5 \leq 0$   
 (c) On the same set of axes, draw the graph of  $y = 2x + 3$   
 (d) Determine the solutions to the equation:  $2x^2 - 4x - 5 = 2x + 3$
12. Complete the table below for the equation  $y = 5 + 3x - 2x^2$  by filling in the blank space

X	-2	-1.5	-1	-0.5	0	0.5	1	1.5	2	2.5	3	3.5
Y	-9			3		6	6				-4	

- (i) Use the values from the table above to draw the graph of  $y = 5 + 3x - 2x^2$  (3mks)
- (ii) Use the graph to:-
- Find the maximum point of the function  $5 + 3x - 2x^2$
  - Determine the range of values and give the integral values which satisfy the inequality  $5 + 3x - 2x^2 \geq -2$



13. (a) Complete the table below for the function  $y = 2x^2 + 4x - 3$

x	-4	-3	-2	-1	0	1	2
$2x^2$	32		8	2	0		
$4x - 3$			-11		-3		5
y			-3			3	13

(b) Draw the graph of the function  $y = 2x^2 + 4x - 3$  and use your graph to estimate the roots of the equation  $2x^2 + 4x - 3 = 0$ .

(c) In order to solve graphically the equation  $2x^2 + x - 5 = 0$ , a straight line must be drawn to intersect the curve  $y = 2x^2 + 4x - 3$ . Determine the equation of this line, draw it and hence obtain the roots of the equation  $2x^2 + x - 5 = 0$  to 1 decimal place.

14. a) Complete the table for the function  $y = 1 - 2x - 3x^2$   $-3 \leq x \leq 3$ .

x	-3	-2	-1	0	1	2	3
$-3x^2$	-27		-3	0		-12	
$-2x$		4		0			-6
1	1	1	1	1	1	1	1
y	-20			1		-15	

b) Using the table above, draw the graph of  $y = 1 - 2x - 3x^2$  (Scale 1 cm represent 0.5 units on **x-axis** and 1 cm rep 2 units on the **y-axis** on the grid provided.

c) Use the graph in (b) above to solve.

(i)  $1 - 2x - 3x^2 = 0$

(ii)  $2 - 5x - 3x^2 = 0$

15. A quadratic equation  $x^2 + ax - b = 0$  has roots 1 and -5, determine the values of a and b

16. Find a quadratic equation whose roots are  $1.5 + 2\sqrt{}$  and  $1.5 - 2\sqrt{}$  expressing it in the form  $ax^2 + bx + c = 0$ , where a, b, and c are integers

17. If  $a^2 + b^2 = 89$  and  $a + b = 13$

(a) Find the values of;

(i)  $a^2 + 2ab + b^2$

(ii)  $2ab$

(iii)  $a^2 - 2ab + b^2$

(iv)  $a - b$

(b) Determine the values of a and b

#### 41. Approximation and errors

- A rectangular room has length 12.0 metres and width 8.0 metres. Find the maximum percentage error in estimating the perimeter of the room
- In this question mathematical tables or calculator should not used. The base and perpendicular height of a triangle measured to the nearest centimeters are 12cm and 8cm respectively; Find ;
  - the absolute error in calculating the area of the triangle
  - the percentage error in the area, giving the answer to 1 decimal place
- A rectangular plate has a perimeter of 28cm. determine the dimensions of the plate that give the maximum area

4. A wire of length 5.2m is cut into two pieces without wastage. One of the pieces is 3.08m long. What is the shortest possible length of the second piece?
5. The dimensions of a rectangle are 10cm and 15cm. If there is an error of 5% in each of the Measurements. Find the percentage error in the area of the rectangle.
6. Find the products of 17.3 and 13.8. Find also the percentage error in getting the product.
7. The mass of a metal is given as 14kg to the nearest 10g. Find the percentage error in this measurement.
8. Complete the table below for the functions  $y = \cos x$  and  $y = 2 \cos (x + 30^\circ)$  for  $0^\circ \leq X \leq 360^\circ$

X	0°	30°	60°	90°	120°	150°	180°	210°	240°	270°	300°	330°	360°
cos X	1	0.87	0.5	0	-0.5	-0.87	-1.0	-0.87	-0.5	0	0.5	0.87	1
2 cos (x + 30°)	1.73	2.0	1.73	1.0	0	-1.0	-1.73	-2.0	-1.73	-1.0	-0.5	0	0.87

- a) On the same axis, draw the graphs of  $y = \cos x$  and  $y = 2 \cos (x + 30^\circ)$  for  $0^\circ \leq X \leq 360^\circ$
  - b)
    - i) State the amplitude of the graph  $y = \cos x^\circ$
    - ii) State the period of the graph  $y = 2 \cos (x + 30^\circ)$
  - c) Use your graph to solve  $\cos x = 2 \cos (x + 30^\circ)$
9. Given that  $8 \leq y \leq 12$  and  $1 \leq x \leq 6$ , find the maximum possible value of:
 
$$\frac{y+x}{y-x}$$

## 42. Trigonometry 2

1. If  $\tan x^\circ = \frac{12}{5}$  and  $x$  is a reflex angle, find the value of  $5 \sin x + \cos x$  without using a calculator or mathematical tables
2. Find  $\theta$  given that  $2 \cos 3\theta - 1 = 0$  for  $0^\circ \leq \theta \leq 360^\circ$
3. Without a mathematical table or a calculator, simplify:  $\frac{\cos 300^\circ \times \sin 120^\circ}{\cos 330^\circ - \sin 405^\circ}$  giving your answer in rationalized surd form.
4. Express in surds form and rationalize the denominator.
 
$$\frac{1}{\sin 60^\circ \sin 45^\circ - \sin 45^\circ}$$
5. Simplify the following without using tables;  
 $\tan 45^\circ + \cos 45^\circ \sin 60^\circ$
6. Simplify the following surds in the form of  $a + b \sqrt{c}$  where  $a$ ,  $b$ , and  $c$  are constants
 
$$\frac{5}{2\sqrt{2} - \sqrt{5}} + \frac{2}{2\sqrt{2} - \sqrt{5}}$$
8. John cycles from shopping centre **A** on a bearing of  $120^\circ$  for 5 km to shopping centre **B**. He then

cycles on a bearing of  $200^{\circ}$  for 7 km to the shopping centre C. Calculate to 1 decimal place.

a) The direct distance from A to C.

b) The bearing of A from C.

c) Bearing of B from C.

### 43. Surds

1. Simplify;  $\frac{3}{\sqrt{7}-2} + \frac{1}{\sqrt{7}}$  leaving the answer in the form  $a + b\sqrt{c}$ , where  $a$ ,  $b$  and  $c$  are rational numbers

2. Given that:  $\frac{2 + \sqrt{5}}{2 - \sqrt{5}} = \frac{3 + \sqrt{5}}{2 + \sqrt{5}} = a + b\sqrt{5}$   
Find the values of  $a$  and  $b$  where  $a$  and  $b$  are rational numbers

3. If:  $\frac{\sqrt{4}}{\sqrt{7}-\sqrt{12}} - \frac{\sqrt{4}}{\sqrt{7}+\sqrt{2}} = a + b\sqrt{2}$  Find the values of  $a$  and  $b$ , where  $a$  and  $b$  are rational numbers \*

4. Rationalize the denominator  $\frac{2 - 2\sqrt{2}}{(2-1)^3}$  and express your answer in the form of  $a + c\sqrt{2}$

5. The figure below is a right pyramid with a rectangular base ABCD and vertex V.

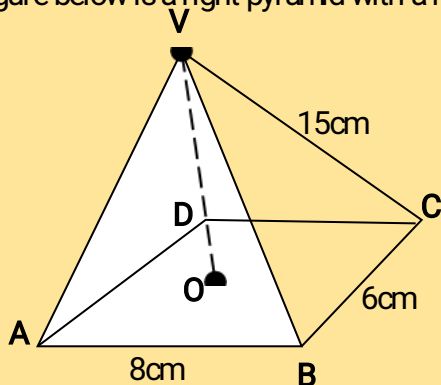

O is the centre of the base and M is a point on OV such that  $OM = \frac{1}{3} OV$ ,  $AB = 8$  cm,  $BC = 6$  cm and  $VA = VB = VD = VC = 15$  cm. Find;

i) The height OV of the pyramid.

ii) The angle between the plane BMC and base ABCD.

6. Find the value of  $y$  which satisfies the equation

$$\log_{10} 5 - 2 + \log_{10} (2y + 10) = \log_{10} (y - 4)$$

7. Simplify the expression  $\frac{\sqrt{3} - \sqrt{2}}{\sqrt{3} + \sqrt{2}}$  giving your answer in the form of  $a + b\sqrt{c}$ .

### 44. Further logarithms

1. In this question, show all the steps in your calculations, giving the answer at each stage.

Use logarithms correct to 4 decimal places, to evaluate;  $\frac{(1934)^2 \times 0.00324}{\log 746}$

2. The table below shows monthly income tax rates

Monthly taxable pay in KE	Rate of the tax (Kshs/ E)
1 - 342	2
343 - 684	3
685 - 1026	4
1027 - 1368	5
1369 - 1710	6
1710 and above	7

Mr. Kamau who is a civil servant earns a Monthly salary of Kshs.20000 and is provided with a house at a

nominal rent of Kshs.700 per month

- a) Taxable pay is the employee's salary plus 15% less nominal rent. Calculate Mr. Kamau's taxable pay
- b) Calculate the total tax Mr. Kamau pays
- c) Mr. Kamau is entitled to a personal relief of Kshs.600 per month. What was his net tax
- d) Mr. Kamau has the following deductions made on his pay;
  - Loan repayment of Kshs.2100 per month
  - NSSF Kshs.200 per month
  - WCPS calculated at 2 % of monthly salary

Calculate Mr. Kipchokes net pay

- 3. A man bought a matatu at Kshs.400,000 in January 1999. It depreciated at a rate of 16% per annum. If he valued it six months, calculate its value in January 2003
- 4. The table shows corresponding values of x and y for a certain curve;

x	1.0	1.2	1.4	1.6	1.8	2.0	2.3
y	6.5	6.2	5.2	4.3	4.0	2.6	2.4

Using 3 strips and mid-ordinate rule estimate the area between the curve, x-axis, the lines  $x=1$  and  $x=2.2$

- 5. Evaluate without using a calculator or mathematical tables.  
$$\frac{\log 32 + \log 128 - \log 729}{\log 32 + \log 2 - \log 27}$$
- 6. Find the value of x that satisfies the equation:-  
 $\log (x+5) = \log 4 - \log(x+2)$
- 7. Find the least number of terms for which the sum of the GP  $100 + 200 + 400 + \dots$  exceeds 3100.
- 8. A two digit number is formed from the first four prime numbers.
  - a) Draw the table to show the possible outcomes, if each number can be used only once.
  - b) Calculate the probability that a number chosen from the digit numbers is an even number
- 9. Find the gradient of a line joining the centre of a circle whose equation is  $x^2 + y^2 - 6x = 3 - 4y$  and a point P(6,7) outside the circle..
- 10. A lady invests shs.10,000 in an account which pays 16% interest p.a. The interest is compounded quarterly. Find the amount in the account after  $1\frac{1}{2}$  hrs
- 11. Use logarithm tables to evaluate  
$$\sqrt[3]{\frac{13.6 \cos 40^\circ}{63.5}}$$
- 12. Without using logarithms or calculator evaluate:  
 $2\log_{10}5 - 3\log_{10}2 + \log_{10}32$
- 13. Evaluate without using tables or calculators.  
 $\log (3x + 8) - 3 \log 2 = \log (x - 4)$

## 45. Commercial Arithmetic 2

1. Chepkemoi bought a new washing machine for Kshs.420,000. Its value depreciated over the next 5years at the following rates, 15%, 13%, 12%, 9% and 7%. For the next 6 years, the rate of depreciation remained constant at 5% then the rate of depreciation remained at 4% each. How long did it take for the value of the washing machine to be  $\frac{1}{3}$  of its original value?

2. The table below shows income tax rates for the year 2006

Taxable income in shs. Pa	Rate of tax in %
1 – 120,000	10
120,001 – 240,000	15
240,001 – 360,000	25
360,001 – 480,000	35
Over 480,000	50

Nafula is married and claims a tax relief of shs.1,120 per month. She stays in a company house for which she pays a nominal rent of shs.1200 per month. She found that in a particular month, her employer deducted shs.4830 as tax. If she is entitled to a maximum insurance policy relief of shs.600 per month. Calculate her monthly salary. (10mks)

3. The figure below represents two pulley wheels, centres A and B with a rubber band CDEFGHC stretched round them. Radius of wheel centre A = 16cm, AB = 30cm. CD, GF are tangents to the circles  $\angle CAB = 86.3^\circ$

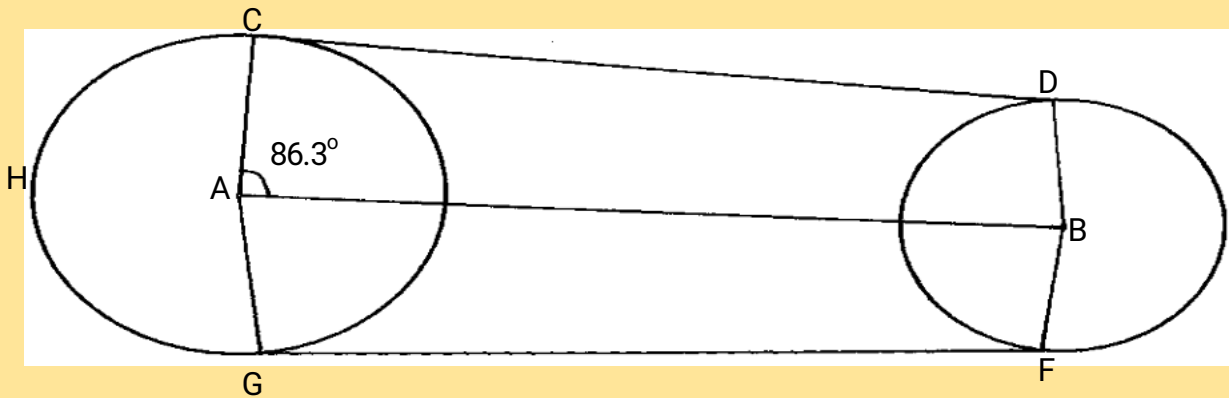

- calculate the length of the belt CD
- Find the angle ABD
- Find the length of the belt that would go round the pulleys (CDFGHC)

4. In the figure below, ABCD is a cyclic quadrilateral and BD is a diagonal. EADF is a straight line,  $\angle CDF = 68^\circ$ ,  $\angle BDC = 45^\circ$  and  $\angle BAE = 98^\circ$ .

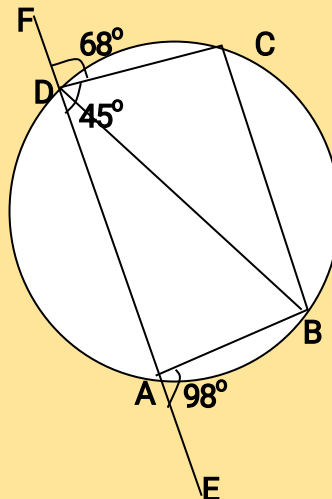

Calculate the size of:

- $\angle ABD$ .
- $\angle CBD$

- A customer deposited Ksh.15,500 in a savings account. Find the accumulated amount after  $3\frac{1}{2}$  years if interest was paid at 16% per annum compounded semi-annually
- A retailer mixes three types of rice, Bismatti costing shs.120 per tin with Pishori costing shs.150 per tin and Ahero rice costing shs.80 per tin in the ratio  $x : 1 : 2$  respectively. If he sells the

mixture at shs.137.50 per tin making a profit of 25%. Calculate the value of x.

7. Ashanti is a saleswoman and earns a commission on sales based on the monthly rates shown in the table below:-

Sales (Kshs)	Commission rate % of sales
The first 5000	10%
The next 3000	15%
Sales above 8000	20%

In addition, she earns a basic monthly pay of Kshs.6700. During a certain month, she earned a total salary amounting to Kshs.8368. How much worth of sales did she make?

9. The table below shows the annual income tax rates for a certain year.

Total income per month in Kshs.	Rates in Kshs. Per £
1-10164	2
10165 – 19740	3
19741 – 29316	4
29317 – 33892	5
33893 and above	6
Automatic personal relief shs.1162	

Kiptoo earns a monthly salary of Kshs.25000. He is entitled to house and medical allowances of Kshs.12000 and Kshs.3000 respectively

Calculate:

- His taxable income per month
  - His monthly tax payable
  - His annual tax payable
10. A company employee earns a basic salary of Kshs.25,000 and is also given taxable allowances amounting to Kshs.10,480.

Monthly taxable income	Rate in Kshs. /Pound
1- 4350	2
4351 – 8900	3
8901 - 13455	4
13451 – 18005	5
18006 and above	6

Using the table of taxation above:-

- Calculate the employee's taxable income
- If the employee is entitled to a personal tax relief of Kshs.800 per month, determine the net tax
- If the employee was given 40% increase in his income, calculate the percentage increase

in his income tax



11. A certain amount of money was invested at compound interest of 10% compounded every two years for ten years. Given that the investor invested a total of 500,000/= at the end of the ten years, find the amount of money invested to the nearest shillings
12. The cash price of a T.V set is Ksh. 26,000. Linda bought the set on hire purchase terms by paying a deposit of Ksh. 6,000 and the balance by 24 equal monthly installments of Kshs. 1,045.30. Find the compound rate of interest per year.
13. What would Kshs.15000 amount to after 3years at 16% per annum compounded quarterly?
14. Income rates for income earned were charged as follows:

Income in Kshs. p.m	Rate in Kshs. per sh.20
1- 8400	2
8401- 18,000	3
18,001- 30,000	4
30,000 - 36,000	5
36,001 - 48,000	6
48,001 and above	7

A civil servant earns a monthly salary of Ksh.19,200. His house allowance is Ksh12,000 per month. Other allowces per month are transport Ksh.1300 and medical allowance Ksh.2300. He is entitled to a family relief of Kshs. 1240 per month.

**Determine:**

- a) (i) His taxable income per month.  
(ii) Net tax.
- b) In addition, the following deductions were made

NHIF	shs. 230
Service charge	Kshs. 100
Loan repayment	Kshs. 4000
Co-operative shares of	Kshs. 1200.

Calculate his net salary per month.

15. Use the taxation rates in the table below to answer the questions that follow;-

Taxable income in K£ p.a	Rate % per K£
1-4500	10
4501-7500	15
7501 – 10500	20
10501 – 13500	25
13501 – 16500	30
Over 16500	35

The manager of a certain company is entitled to a monthly personal relief of shs.3000 and her tax (PAYE) is kshs.9000 per month she is also deducted NHIF shs.350 per month, WCPS shs.800 per month and cooperative shares shs.1200 per month, **calculate**

- (a) The managers total deductions per month
- (b) Total tax per month
- (c) The manager's annual gross salary
- (d) The manager's monthly basic salary if her monthly allowance and medical allowances are 10000 and 2000 shillings

16. The table below shows the income tax for a certain year;

Monthly taxable income (Kshs.)	Tax rates (%)
1- 9680	10%
9681- 18800	15%
18801 – 27920	20%
27921 – 37040	25%
37940 and above	30%

In that year, Odero paid a net tax of Kshs.5,512 per month. His total monthly taxable allowances amounted to Kshs.15,220 and he was entitled to a monthly personal relief of kshs.1,162.

Every month the following deductions were made;

N.H.I.F Kshs.320

Union dues Kshs.200

Co-operative shares Kshs.7,500

(a) Calculate Odero's monthly basic salary in Kshs

(b) Calculate his monthly salary

17. (a) A car is worth shs.800,000 when new. During the first year it depreciates by 20% of its value and in the second it depreciates by 5% of its value at the start of the year. During the third, fourth and fifth year, depreciation rate is 10%. How much less will it cost at the end of the fifth year?
- (b) Find by how much the compound interest will exceed simple interest on shs.3,000 for two years at 15% per year

18. The table below shows the income tax rates:

Income per month (K£)	Rate in Kshs per £
1 - 325	2
326 – 975	3
976 - 1300	5
1301 – 1625	6
Over 1625	7.50

Mr. Misoi is a public servant who lives in a government house and pays a nominal rent of Kshs.1,220 per month. He earns a basic salary of Kshs. 24,800 and a house allowance of Kshs.12,000 per month. He is entitled to a monthly relief of kshs.1620.

(a) Calculate his monthly;

(i) Taxable income in K£

(ii) Tax payable without relief

(iii) Tax after relief

(b) Apart from the income tax. The following monthly deductions are made from his earnings

-HELB loan repayment Kshs.2400

- Health insurance fund Kshs.1200

- 2% of Basic salary union fee

Calculate:- (i) the total monthly deduction made on Mr. Misoi's income

(ii) Mr. Misoi's net income per month



19. Joseph bought a camera on hire purchase (H.P) term by paying a deposit of shs.7200 and cleared the balance in 24 equal monthly installments each of 1250.
- find the hire purchase price of the camera
  - the hire purchase price of the camera is 24% higher than the cash price. Find the cash price of the camera
  - Kangara took a loan from a financial institution and bought the camera with cash. He repaid the loan at 18% p.a compound interest at the end of the two years. Find the total interest paid by Kangara.
20. Income tax for all the income earned was charged at the rates shown.

Total Income p.a (K.£)	Rate in sh per K£
1 – 1980	2
1981 – 3960	3
3961 – 6440	5
6441 – 7920	7
7921 – 9900	9
Excess of 9900	10

- Wanyonyi earned a salary of Kshs.10,500 per month. In addition he was given a house allowance of Kshs. 6500 per month. He got tax relief of Kshs. 300 per month.  
Find ; (i) His taxable income p.a  
(ii) Income tax he pays per month.
- A part from income tax the following deductions are made per month. NHIF of Kshs.320, widow and pension scheme of 2% of his gross salary. Calculate his net monthly pay.

#### 46.Circles –chords and tangents

1. In the figure below angle  $BAC = 52^\circ$ , angle  $ACB = 40^\circ$  and  $AD = DC$ . The radius of the circle is 7cm EF is a tangent to the circle

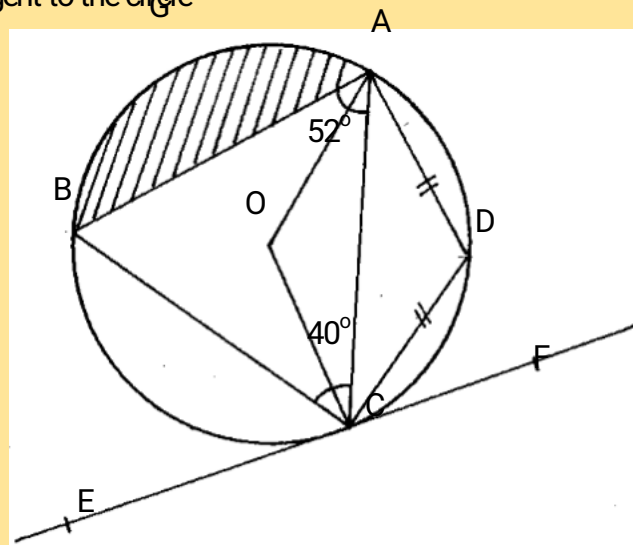

- Find; giving reasons
  - angle DCF
  - angle AOB (obtuse)
- Calculate the area of the shaded segment AGB

2. In the figure below, O is the centre of the circle. Angle CBA =  $50^\circ$  and angle BCO =  $30^\circ$ . Find the size of the angle BAC

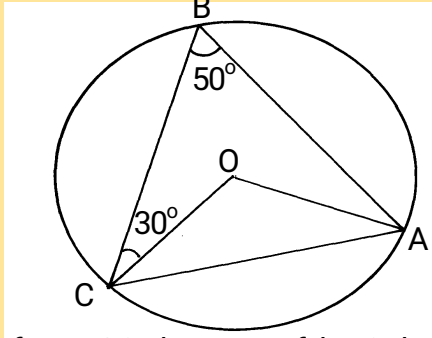

3. In the given figure, O is the centre of the circle and AOBP is a straight line. PT is a tangent to the circle. If PT = 12cm and BP = 4cm find the radius of the circle

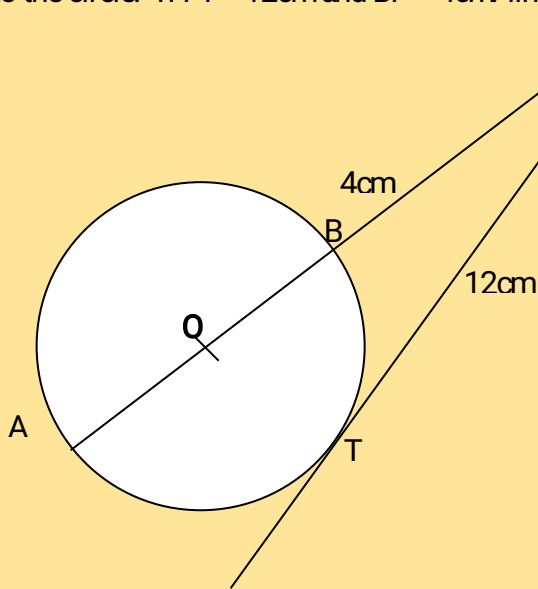

4. In the figure below AOD is a diameter of the circle centre O. BC is a chord parallel to AD. FE is a tangent to the circle. OF bisects angle COD. Angle BCE = angle COE =  $20^\circ$  BC cuts OE at X

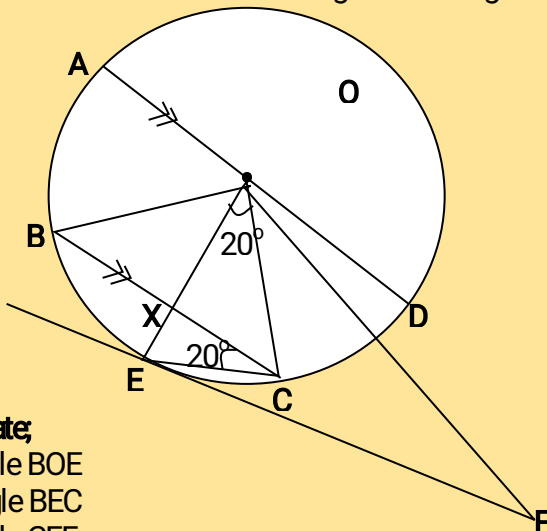

**Calculate;**

- angle BOE
- angle BEC
- angle CEF
- angle OXC
- angle OFE

5. The figure below shows two pulleys of radii 6cm and 4cm with centres **A** and **B** respectively. **AB** = 8cm. The pulleys are connected by a string PQXRSY

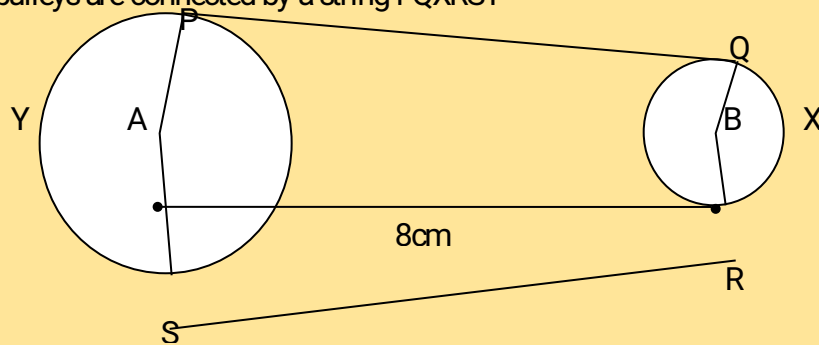

Calculate:

- Length PQ
  - $\angle$ PAS reflex
  - Length of arc PYS and QXR
  - The total length of the string PQXRSY
6. a) Two pipes **A** and **B** can fill a tank in 3hrs and 4 hrs respectively. Pipe **C** can empty the full tank in 6 hrs.
- How long would it take pipes **A** and **B** to fill the tank if pipe **C** is closed?
  - Starting with an empty tank, how long would it take to fill the tank with all pipes running?
- b) The high quality Kencoffee is a mixture of pure Arabica coffee and pure Robusta coffee in the ratio 1 : 3 by mass. Pure Arabica coffee costs shs. 180 per kg and pure Robusta coffee costs sh 120 per kg. Calculate the percentage profit when the coffee is sold at sh 162 per kg.
7. In the figure below, ABCD is a cyclic quadrilateral and BD is a diagonal. EADF is a straight line,  $\angle$ CDF =  $68^\circ$ ,  $\angle$  BDC =  $45^\circ$  and  $\angle$  BAE =  $98^\circ$ .

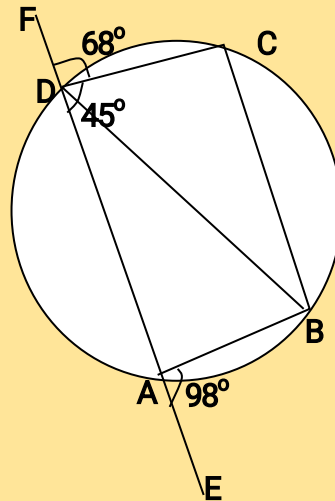

Calculate the size of:

- $\angle$  ABD.
  - $\angle$  CBD
8. The figure below shows a circle centre **O**. **AB** and **PQ** are chords intersecting externally at a point **C**. **AB** = 9cm, **PQ** = 5cm and **QC** = 4cm. Find the value of **x**

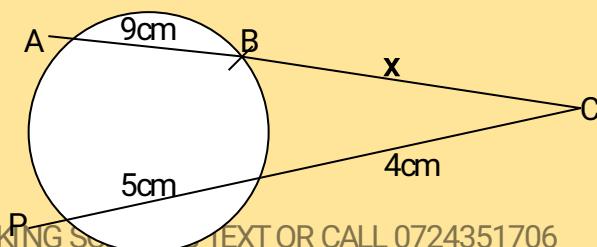

9. The chords AB and PQ intersect internally at O. Given that the length of OP=8cm, OA= 4.5cm and OQ=6cm. Calculate the length of OB

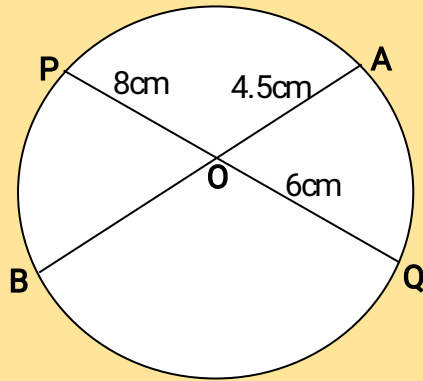

10. In the figure below ABC is a tangent to the circle at B. given that  $\angle ABG=40^\circ$ ,  $\angle BGD=45^\circ$ , and  $\angle DBE=25^\circ$  as shown below.

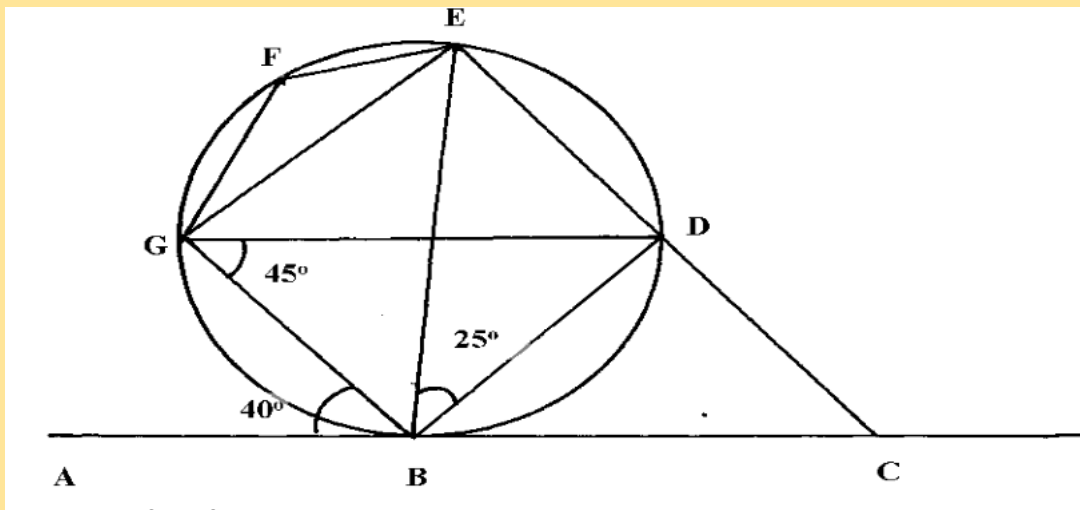

Find the sizes of the following angles giving reasons in each case:

- $\angle BDG$
  - $\angle DGE$
  - $\angle EFG$
  - $\angle CBD$
  - $\angle BCD$
11. The figure below shows two intersecting circles radii 8 cm and 6 cm respectively. The common chord AB = 9cm and P and Q are the centres as shown:

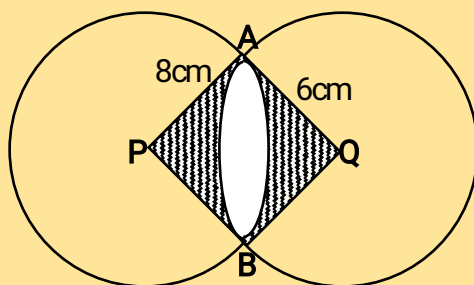

- (a) Calculate the size of angles:-
- $\angle APB$
  - $\angle AQB$

(b) Calculate the area of the shaded region

12. The figure O and P are centres of two intersecting circles. ABE is tangent to circle BCD at B angle BCD is  $42^\circ$

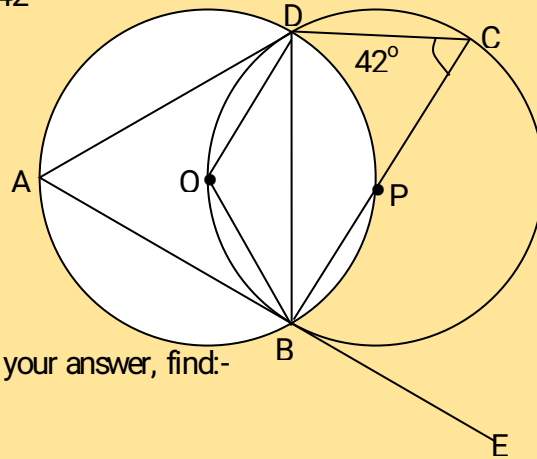

(a) Giving reasons for your answer, find:-

- (i)  $\angle CBD$
- (ii)  $\angle DOB$
- (iii)  $\angle DAB$
- (iv)  $\angle CDA$

b) Show that  $\triangle ADB$  is isosceles

13.

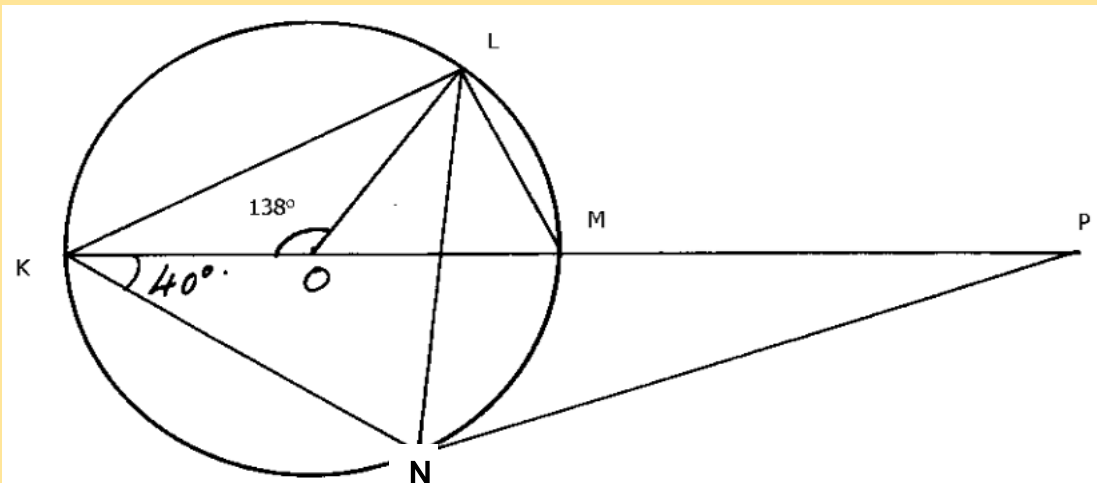

In the figure above K, M & P are points on a straight line. PN is a tangent of the circle centre O. Angle KOL =  $130^\circ$  and angle MKN =  $40^\circ$ . Find, giving reasons, the values of angles.

- (i)  $\angle MLN$
- (ii)  $\angle OLN$
- (iii)  $\angle LNP$
- (iv)  $\angle MPN$
- (v)  $\angle LMO$

14. In the diagram below, O is the centre of the circle of radius 8cm. BA and BC are tangents to the circle at A and C respectively. PD is the diameter and AC is a chord of length 8cm. Angle ADC =  $120^\circ$ . ARC is an arc of the circle, Centre B and radius 4.6cm

Calculate correct to 2 decimal places

- (a) Angle ABR
- (b) Area of sectors ABCR and OAPC
- (c) Area of the shaded part

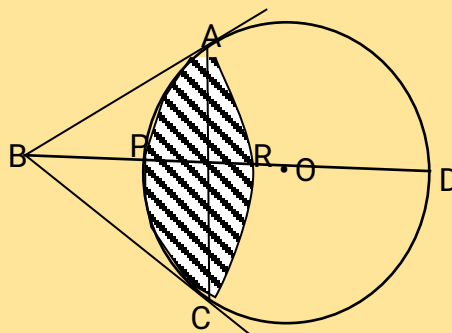



15. In the figure below,  $ATX$  is a tangent to the circle at point  $T$ ,  $ABC$  is a straight line, angle  $ABT = 100^\circ$ , angle  $XTD = 58^\circ$  and line  $AB =$  line  $BT$ .  $C$  and  $D$  lie on the circle

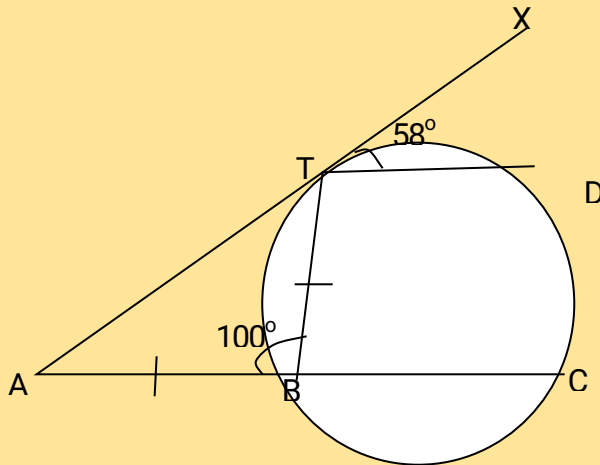

Find by giving reasons, the value of angle:

- TDC
  - TCB
  - TCD
  - BTC
  - DTC
16. In the figure below,  $B, D, E, F$  and  $G$  are on the circumference of the circle centre  $O$ .  $A, B$  and  $C$  form a tangent to the circle at point  $B$ .  $GD$  is the diameter of the circle. Given that  $FG = DE$ , reflex angle  $GOB = 252^\circ$ , angles  $DBC = 36^\circ$  and  $FEG = 20^\circ$

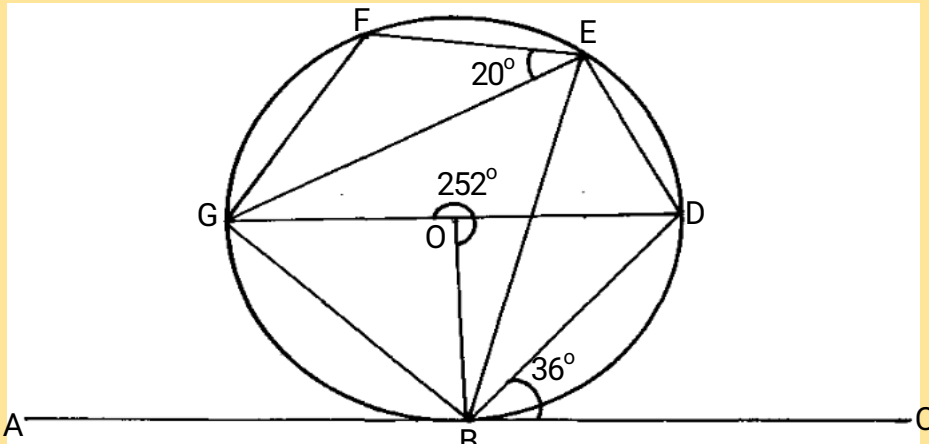

Giving reasons in each case find the angles

- GEB
  - BED
  - OBE
  - BGE
  - GFE
17.  $XYZ$  is a triangle in which  $x = 13.4\text{cm}$ ,  $Z = 5\text{cm}$  and  $\angle XYZ = 57.7^\circ$ . Find:
- Length of  $XZ$
  - The circum radius of the triangle
18. In the figure shown below, the centers of the two circles are  $A$  and  $B$ .  $PQ$  is a common chord to the two circles.  $AP = 6\text{cm}$ ,  $BP = 4\text{cm}$  and  $PQ = 5\text{cm}$

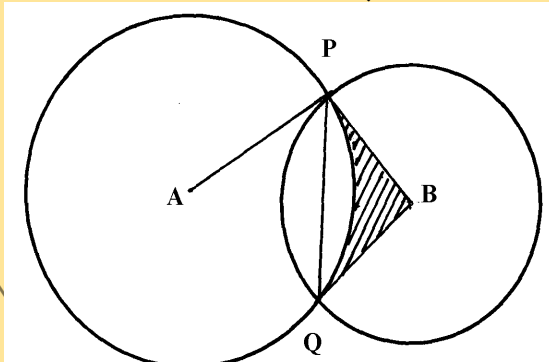

19. Calculate the area of the shaded region (take  $\pi$  as 3.142)  
 In the figure below NR is a diameter of the circle centre O. Angle PNR =  $75^\circ$   $\angle$  NRM =  $50^\circ$  and  $\angle$  RPQ =  $35^\circ$ . MRS and PQS are straight lines.

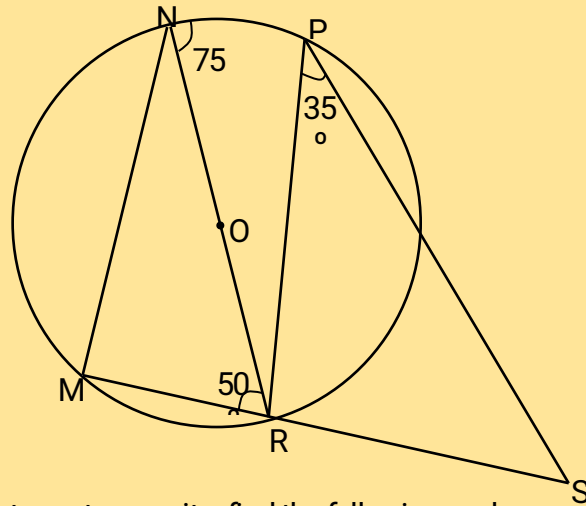

Giving reasons for every statement you write, find the following angles

- (a)  $\angle$  PQR
  - (b)  $\angle$  QSR
  - (c) Reflex  $\angle$  POR
  - (d)  $\angle$  MQR
  - (e)  $\angle$  PON
20. In the diagram below, ATX is a tangent to the circle at point T, ABC is a straight line,  $\angle$ ABT =  $100^\circ$ ,  $\angle$ XTD =  $58^\circ$  and the line AB = BT

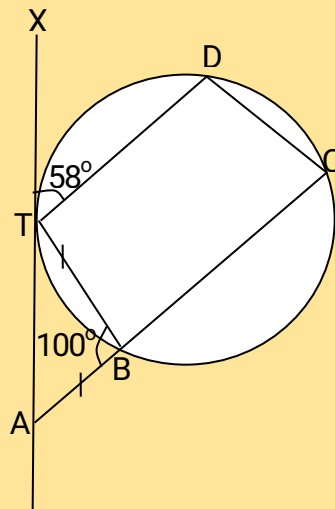

Find giving reasons the value of :

- (a)  $\angle$  TDC
  - (b)  $\angle$  TCB
  - (c)  $\angle$  TCD
  - (d)  $\angle$  BTC
  - (e)  $\angle$  DTC
- 21.

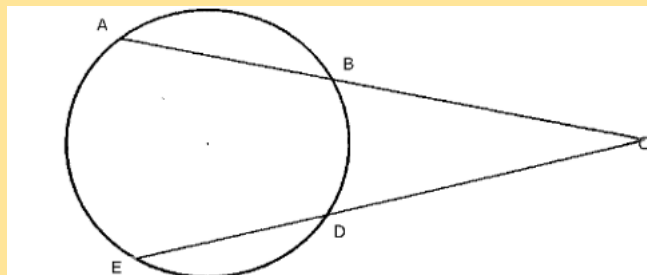

In the figure above  $AB = 6\text{ cm}$ ,  $BC = 4\text{ cm}$ ,  $DC = 5\text{ cm}$ . Find the length  $DE$ .

22. The eleventh term of an AP is four times the second term. If the sum of the first seven terms of the AP is 175, find the first term and the common difference
23. In the diagram below  $ABE$  is a tangent to a circle at  $B$  and  $DCE$  is a straight line.

If  $\angle ABD = 60^\circ$ ,  $\angle BOC = 80^\circ$  and  $O$  is the centre of the circle, find with reasons  $\angle BEC$

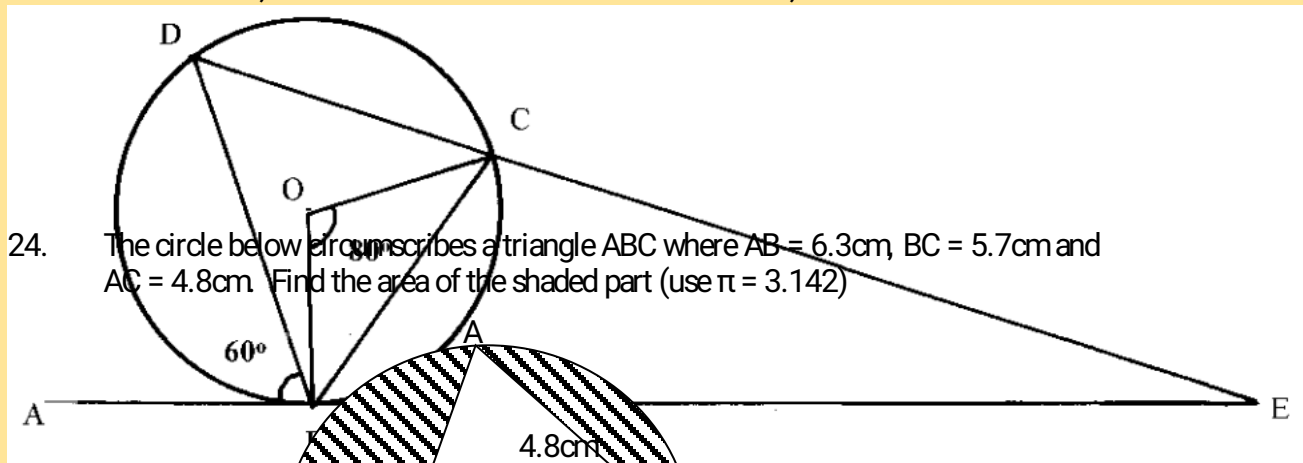

25.

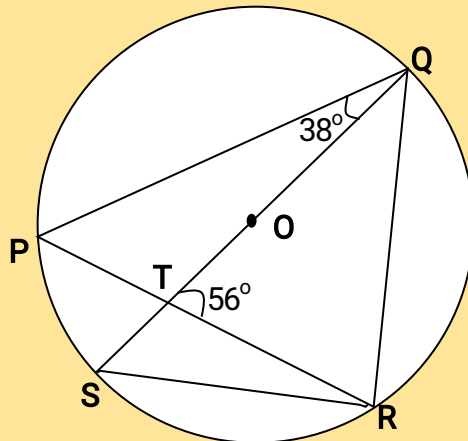

- (a)  $O$  is the centre of the circle and  $QOTS$  is a diameter.  $P$ ,  $Q$ ,  $R$  and  $S$  are points on the circumference of the circle. Angle  $PQS = 38^\circ$  and angle  $QTR = 56^\circ$ . Calculate the size of ;
- (i)  $\angle PRQ$
- (ii)  $\angle RSQ$
- (b) Given that  $A$  varies directly as  $B$  and inversely as the cube of  $C$  and that;  
 $A = 12$  when  $B = 3$  and  $C = 2$ . Find  $B$  when  $A = 10$  and  $C = 1.5$
- (c) A quantity  $y$  is partly constant and partly varies inversely as the square of  $x$ .  
 The quantity  $y=7$  when  $x=10$  and  $y=5\frac{1}{2}$  when  $x=20$ . Find the value of  $y$  when  $x=18$

26. The figure below shows two intersecting circles with centres P and Q and radius 5cm and 6cm respectively. AB is a common chord of length 8cm. Calculate;

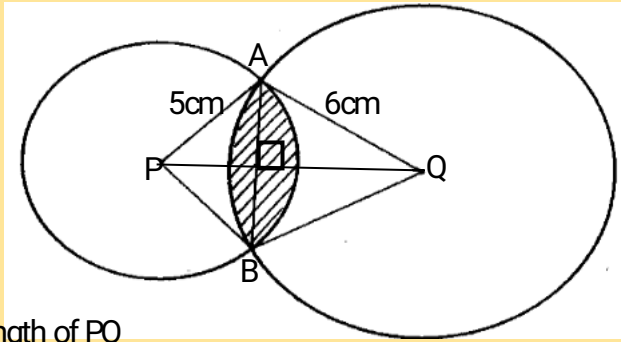

- (a) the length of PQ  
 (b) the size of,  
 (i) angle APB  
 (ii) angle AQB  
 (c) the area of the shaded region
27. Triangle ABC is inscribed in the circle. AB= 7.8cm, AC 6.6cm and BC= 5.9cm. Find:

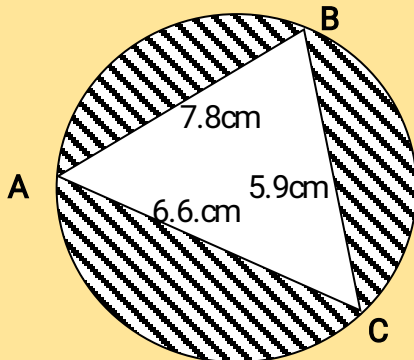

- (a) The radius of the circle correct to one decimal place  
 (b) The area of the shaded region
28. The figure below shows two circles centres A and B and radii 6 cm and 8 cm respectively. The circles intersect at P and Q. Angle PAB =  $42^\circ$  and angle ABQ =  $30^\circ$ .

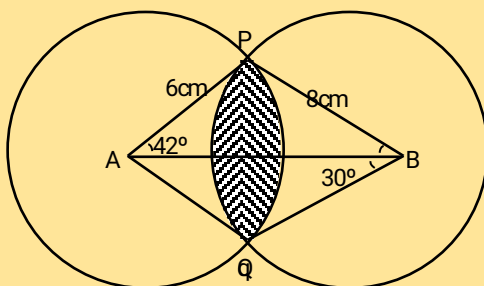

- (a) Find the size of  $\angle PAQ$  and  $\angle PBQ$ .  
 (b) Calculate, to one decimal place the area of:  
 (i) Sector APQ and PBQ.  
 (ii) Triangle APQ and PBQ.  
 (iii) The shaded area (take  $\pi \approx 22$ )
29. The minute hand of a clock is 6.5 cm long. Calculate the distance in cm moved by its tip between 10.30 am. and 10.45 am to 2 dpl.

## 47. Matrices

1. Given that A is  $\begin{pmatrix} 3 & 2 \\ 4 & -1 \end{pmatrix}$  and  $A^{-1} = \begin{pmatrix} 2 & 11 \\ 4 & -3 \\ 11 & 11 \end{pmatrix}$

Find the value of a and b in the expression:

(3 mks)

$$\begin{pmatrix} 3 & 2 \\ 4 & -1 \end{pmatrix} \begin{pmatrix} a \\ b \end{pmatrix} = \begin{pmatrix} 12 \\ 5 \end{pmatrix}$$

2. Solve for the unknowns given that the following is a singular matrix.

$$\begin{pmatrix} 1 & 2 \\ x & x-3 \end{pmatrix}$$

3. Given that  $A = \begin{pmatrix} 1 & 5 \\ 3 & 7 \end{pmatrix}$  and  $B = \begin{pmatrix} 7 & 3 \\ -4 & -2 \end{pmatrix}$  and that  $C = AB$ , find  $C^{-1}$

4.  $\tilde{B}$  is a matrix  $\begin{pmatrix} 3 & 2 \\ 2 & 2 \end{pmatrix}$  and  $\tilde{C}$  is the matrix  $\begin{pmatrix} 9 & -3 \\ 2 & 1 \end{pmatrix}$

If  $\tilde{A}$  is a  $2 \times 2$  matrix and  $\tilde{A} \times \tilde{B} = \tilde{C}$ , determine the matrix  $\tilde{A}$ .

5. An object of area  $20 \text{ cm}^2$  undergoes a transformation given by the matrix  $\begin{pmatrix} -1 & -2 \\ 4 & 3 \end{pmatrix}$  followed by  $\begin{pmatrix} 2 & 3 \\ -1 & 2 \end{pmatrix}$  find the area of the final image.

6. Find the matrix B such that  $AB = I$  and  $A = \begin{pmatrix} 2 & 1 \\ 1 & 3 \end{pmatrix}$ . Hence find the point of intersection of the lines  $3x + 2y = 10$  and  $3y - 4 = x$ .

7. Given that  $P = \begin{pmatrix} 2 & 3 \\ 1 & 2 \end{pmatrix}$  and  $Q = \begin{pmatrix} 2 & -3 \\ -1 & 2 \end{pmatrix}$  find the matrix product PQ. Hence solve the simultaneous equations below:-  
 $2x - 3y = 5$   
 $-x + 2y = -3$

8. Solve for  $x$  and  $y$  in the following matrix equation using elimination method

$$\begin{pmatrix} 1/2 & -1/4 \\ 2/5 & 1/6 \end{pmatrix} \begin{pmatrix} x \\ y \end{pmatrix} = \begin{pmatrix} 2 \\ 6 \end{pmatrix}$$

9. A triangle XYZ, X(-1, -1), Y(-2, -4) Z(-6, -9) is reflected in the line X axis followed by a reflection in line  $X = Y$ . Find the image of the final image

10. Triangle ABC is the image of triangle PQR under a transformation  $M = \begin{pmatrix} 2 & 4 \\ 0 & 2 \end{pmatrix}$  (where P, Q, R map onto A, B, C respectively). Given the points P(5, -1) Q(6, -1) and R(4, -0.5) draw the triangle ABC on the grid provided.

b) Triangle ABC in (a) above is to be enlarged by scale factor 2 with centre at (11, -6) to map onto  $A^1B^1$  and  $C^1$ . Construct and label triangle  $A^1B^1$  and  $C^1$  on the same grid.

c) By construction, find the coordinates of the centre and the angle of rotation which can be used to rotate triangle  $A^1B^1C^1$  onto triangle  $A^{11}B^{11}C^{11}$  whose coordinates are (-3, -2), (-3, -6) and (-1, -2) respectively.

11. Triangle ABC with an area of  $15 \text{ cm}^2$  is mapped onto triangle  $A^1B^1C^1$  using matrix  $M = \begin{pmatrix} 2 & -3 \\ 1 & 1 \end{pmatrix}$ . Find the area of triangle  $A^1B^1C^1$ .
12. T is a transformation represented by the matrix  $\begin{pmatrix} 5x & 2 \\ -3 & x \end{pmatrix}$  under T a square whose area is  $10 \text{ cm}^2$  is mapped onto a square of area  $110 \text{ cm}^2$ . Find the possible values of X
13. Triangle  $A^1B^1C^1$  is the image of  $\Delta ABC$  under a transformation represented by the matrix  $M = \begin{pmatrix} 3 & 2 \\ 9 & 5 \end{pmatrix}$   
If the area of triangle  $A^1B^1C^1$  is  $54 \text{ cm}^2$ . Determine the area of triangle ABC
14. Find the matrix B such that  $AB = I$  and  $A = \begin{pmatrix} 2 & 1 \\ 1 & 3 \end{pmatrix}$ . Hence find the point of intersection of the lines  $3x + 2y = 10$  and  $3y - 4 = x$ .

#### 48. Formulae and variation

1. P varies as the square of R. R. varies as the square of T. When  $P = 18$ ,  $R = 3$  and  $T = 5$ . Express P in terms of T hence find P when  $T = 10$ .

2. Make r the subject of the formula.

$$v = \sqrt{\frac{r}{r+c}}$$

3. X varies as the cube of Y and inversely as square root of Z,  $X = 6$  when  $Y = 3$  and  $Z = 25$ .  
(a) Find;  
(i) An expression connecting X,Y,Z  
(ii) X when  $Y = 7$  and  $Z = 9$   
(iii) Y when  $X = 8$  and  $Z = 16$   
b) If Y is increased by 20% and Z is decreased by 36%, find the percentage increase in X

4. Make b the subject of the formula;

$$K = \frac{a b}{b - a}$$

5. Find a quadratic equation whose roots are  $2.5 + 3\sqrt{5}$  and  $2.5 - 3\sqrt{5}$  expressing it in the form  $ax^2 + bx + c = 0$  Where a, b and c are integers
6. A quantity Z varies directly as the square of x and inversely as the square root of y. If x increases by 20% and y decreases by 36%, find the percentage change in Z
7. The fourth terms of a G.P is 48 and the seventh term is 384. Find the common ratio and hence calculate the sum of the first six terms
8. A quantity P varies directly as the square of Q and inversely as quantity R. If  $P = 2$  when  $Q = 4$  and  $R = 6$ , find P when  $Q = 8$  and  $R = 4$

9. **B** varies partly as the square of **M** and partly as the inverse of **N**. **B**, **M** and **N** are such that when **M**=2, **N**= ½, **B**=96 while when **M**=√3, **N**=2, **B** = 46. Write an expression for **B** in terms of **M** and **N**.

10. Solve for **x** and **y**.

$$\frac{3x}{y-1} = 1$$

$$(2x+2) : (y-5) = 1 : 2$$

11. Make **x** the subject of the formula.  $P = \left( \frac{x-1}{x+2} \right)$

12. Make **d** the subject of the formula given that:-

$$a^2 = \sqrt{\frac{1+d^2+b}{b^2 \cdot 3}}$$

13. **Z** varies jointly as the square of **x** and inversely as the square of **y**. When **x** = 10 and **y** = 4 then **z** = 15

(a) Find **z** in terms of **x** and **y**

(b) Find the value of **x** when **z** = 8 and **y** = 12

14. A quantity **R** partly varies as **n** and partly as the square root of **n**. When **n** = 9 **R** = 42 and when **n** = 25 **R** = 100. Find **R** when **n** = 16.

15. Make **b** the subject of the formula.

$$a = \frac{bd}{\sqrt{b^2+d}}$$

16. **P** varies partly as **Q** and partly as the square root of **Q**. When **Q** = 4, **P** = 22 and when **Q** = 9, **P** = 42. Find the value of **P** when **Q** = 25.

18. Make **C** the subject of the formula

$$b = \sqrt{k-aC}$$

hence find the value of **C** when **K**= 1, **a** = 4 and **b** = 2

18. The velocity of water flowing through a pipe is inversely proportional to the square of the radius of the pipe. If the velocity of the water is 30cm/s when the radius of the pipe is 2cm. Find the velocity of water when the radius of the pipe is 4cm

19. Make **x** the subject of the formula

$$P = 3\sqrt{\frac{xy}{z+x}}$$

20. Three quantities **x**, **y** and **z** are such that **x** varies partly as **y** and partly as the inverse of the square of **Z**. When **x** = 6, **y** = 3 and **z**= 2. When **x** = 8, **y** = 5 and **z**= 1. Find the value of **x** when **y** = 10 and **z** = 8

21. The eleventh term of an AP is four times the second term. If the sum of the first seven terms of the AP is 175, find the first term and the common difference

22. The resistance of an electrical conductor is partly constant and partly varies as the temperature. When the temperature is  $20^{\circ}\text{C}$ , the resistance is 55 ohms. When the temperature is  $28^{\circ}\text{C}$ , the resistance is 58 ohms. Find the resistance when the temperature is  $60^{\circ}\text{C}$
23. Expand  $(2x)^{-1} - 1^5$  up to the term in  $x^3$ . Hence or otherwise evaluate  $(0.98)^5$  to 4 d.p

#### 49. Sequence and series

- The area covered by Mau forest is  $40,000 \text{ km}^2$  at present. If the human encroachment rate is estimated to be 2 % every 10 years. Calculate the area of the forest encroached in 30 years.
- Three consecutive terms of geometric progression are  $3^{2x+1}$ ,  $9^x$  and 81 respectively. Calculate:
  - The value of  $x$
  - Find the common ratio
  - Calculate the sum of the first 10 terms of this series
  - Given that the fifth and the seventh terms of this G.P forms the first two consecutive terms of arithmetic sequence, calculate the sum of the first 20 terms of this sequence
- How many terms of the sequence  $-12 + -10 + -8 \dots$  should be added to give a sum of 338?
- An arithmetic progression whose first term is 2 and whose  $n^{\text{th}}$  term is 32 has the sum of its  $n$  terms equal to 357. Find  $n$
- 

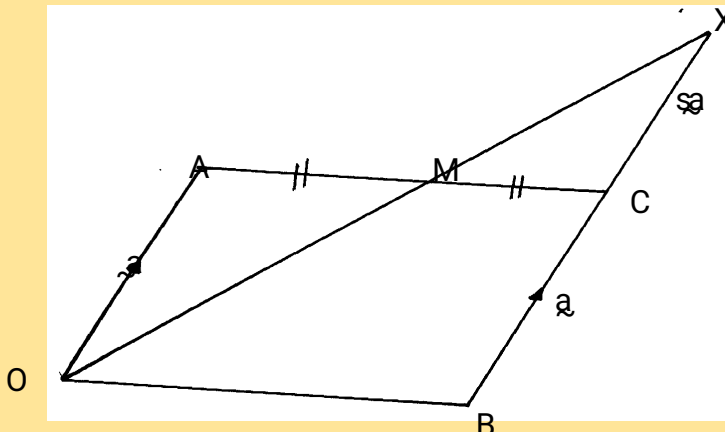

In the figure OACB is parallelogram in which M is the mid- point of AC and OM produced meets BC also produced at X.

Given  $OA = a$  and  $OB = b$

- Express  $OC$  in terms of  $a$  and  $b$
  - Find the values of  $r$  and  $s$  such that  $OX = rOM$  and  $CX = sBC$
  - Hence determine the ratio  $BC:BX$
- For the series  $29 + 23 + \dots + (-91)$ , find;
    - The number of terms in the above series
    - The sum of the series
  - Given that 5,  $a$ ,  $b$ , and 7 are in arithmetical progression, find the value of  $a$  and  $b$
    - If 5,  $P$ ,  $Q$ ,  $\frac{135}{8}$  are in geometrical progression. Find the value of  $P$  and  $Q$
    - Prove that the sum of the first 12 terms of the first series in (a) is approximately equal to the sum of the first 6 terms of the second series (b) above
  - An aeroplane flew East for 640km then turned and flew on a bearing of  $050^{\circ}$ . After 2.5hrs flying at 324km/hr, it was necessary to fly to the original point because of technical hitch.



How much shorter is it going to cover flying straight to the starting point than retracing its former route?

9. A ball falls vertically from a height of 15m. Each time it bounces back to 50% of the height achieved on the previous bounce. Find the distance covered after 6 such bounces
10. Find the sum of the first 51 terms of the series:-  
-22, -19, -16.....
11. Olunga saves shs.100 on his son's first birthday. He saves shs.200 on the second birthday and Shs.400 on the third birthday and so on doubling the amount on every birthday. How much will he be saving on the boy's 10th birthday.
12. A self-help group intended to purchase a dry cleaning machine worth shs.720,000. The members were required to contribute equal amounts to pay for the machine. The group recruited 20 more members consequently, each member paid shs.3000 less than what he would have contributed.  
(a) find the original number of members  
(b) find the amount required from each member to contribute after the recruitment
13. Find the number of terms in the following sequence  
8, 4, 2,  $\frac{1}{2}$  .....,  $\frac{1}{512}$
14. An arithmetic progression has the first term  $a$  and the common difference  $d$   
a) Write down the third, ninth and twenty fifth terms of the progression in terms of  $a$  and  $d$   
b) The arithmetic progression above is increasing and that the third, ninth and twenty fifth terms form the first three consecutive terms of a geometric progression. The sum of the seventh and twice the sixth terms of the arithmetic progression is 78.  
Calculate:  
i) The first term and common difference of the arithmetic progression  
ii) The sum of the first nine terms of the arithmetic progression
15. The difference between the fourth and the seventh terms of an increasing arithmetic progression

## 50. Vectors 2

1.

In the figure alongside  $OA = \vec{a}$ ,  $OB = \vec{b}$ . T lies on AN such that  $AN : TN = 13:6$ . M lies on AB such that  $AM:MB=1:3$  and N lies on OB such that  $ON:NB = 7:5$ .

(a) Express in terms of  $a$  and  $b$  in the simplest form  
(i)  $\vec{AN}$   
(ii)  $\vec{AT}$   
(iii)  $\vec{AM}$

(b) Show that  $O$ ,  $T$  and  $M$  are collinear and state the ratio of  $OT: TM$

2. A point  $(-3, 4)$  divides  $AB$  internally in the ratio 3:5. Find the coordinates of point  $A$  given that point  $B$  is  $(6, -5)$
3. Given that  $O$  is the origin,  $OA = 3i + 2j - 4k$  and  $OB = 6j + 11j + 2k$ . If  $x$  divides  $AB$  in the ratio 1:2, find the modulus of  $OX$  to 2d.p
4. a) Expand  $(2 - \frac{1}{5x})^5$

b) Hence use the expansion to find the value of  $(1.96)^5$  correct to 3 decimal places

5. In the figure OABC is a trapezium in which  $3 \vec{AB} = 2\vec{OC}$ . S divides OC in the ratio 2:1 and AS produced meets BC produced at T

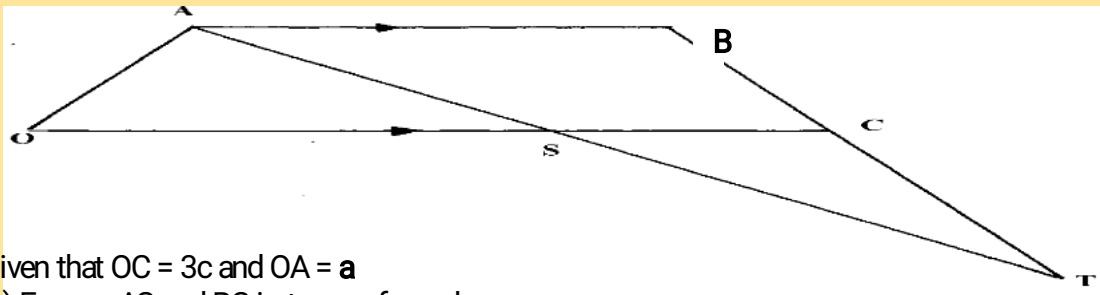

Given that  $OC = 3c$  and  $OA = a$

- Express  $\vec{AS}$  and  $\vec{BC}$  in terms of  $a$  and  $c$
- Given further that  $\vec{AT} = h\vec{AS}$  and  $\vec{BT} = k\vec{BC}$  where  $h$  and  $k$  are constants
  - Express  $\vec{AT}$  in two ways in terms  $a, c, h$  and  $k$
- The obtuse angle between the lines  $PQ$
- Hence find the ratio  $\vec{BT} : \vec{BC}$

- 6.

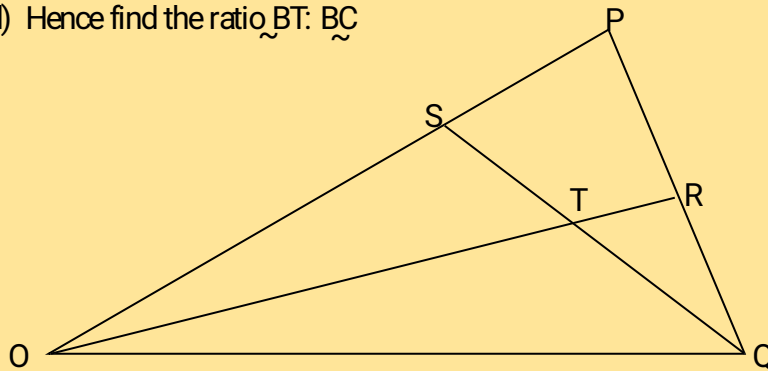

In the figure above,  $OPQ$  is a triangle in which  $OS = \frac{3}{4} OP$  and  $PR:RQ = 2:1$ . Lines  $OR$  and  $SQ$  meet at  $T$ .

- Given that  $OP = p$  and  $OQ = q$ , express the following vectors in term of  $p$  and  $q$ 
  - $\vec{PQ}$
  - $\vec{OR}$
  - $\vec{SQ}$
- You are further given that  $\vec{ST} = m \vec{SQ}$  and  $\vec{OT} = n \vec{OR}$ . Determine the values of  $m$  and  $n$

## 51. Binomial expansion

- Expand  $(1 - 3x)^5$
  - use your expansion to estimate the value of  $0.997^5$  correct to 4 d.p.
- Expand  $(5 + \frac{x}{2})^5$  upto the term in  $x^3$
  - Use your expansion to estimate the value of  $(\frac{11}{2})^6$  correct to one decimal place
- Expand  $(3 + 2x)^6$  up to the fourth term
  - Use your expansion to estimate:  $(3.3)^6$
- Two dice are thrown once and their sum noted. Find the probability that the sum is odd
- Find the length  $PR$  in a triangle  $PQR$  having  $PQ = 12\text{cm}$ ,  $QR = 8.4\text{cm}$  angle  $QPR = 35^\circ$  and angle  $PRQ = 75^\circ$  leaving your answer correct to decimal places
- Use binomial expansion to evaluate  $(2+3)^5$  up to the fifth term
  - By expressing  $9.5$  in the form  $(2 + \frac{3}{x})$ , use the expansion in (a) above to calculate  $(9.5)^5$

correct to 3 d.p

x

7. Use the expansion of  $(x - 0.2)^5$  to find the exact value of  $9.8^5$
8. Solve for  $x$  in the equation;  
 $\log(x + 24) = 2 \log 3 + \log(9 - 2x)$ .
9. Expand  $\left(1 + \frac{x}{12}\right)$  in ascending powers of  $x$  upto the fourth term  
Use the four terms to evaluate  $5\sqrt[4]{6}$  to 4 decimal places.
10. (a) Expand and simplify the binominal expression  $(1 + \frac{1}{2}x)^8$   
(b) Use the expansion up to the fourth term to evaluate  $(1.05)^8$  to 2 decimal places
11. Expand  $(3 + x)^4$  in ascending powers of  $x$ . Use the first three terms of the expansion to evaluate  $(3.02)^4$ , correct to 3 decimal places

## 52. Probability

1. A bag contains 3 black balls and 6 white ones. If two balls are drawn from the bag one at a time, find;
  - (a) The probability of drawing a black ball and a white ball.
    - (i) Without replacement.
    - (ii) With replacement.
  - (b) Drawing two white balls.
    - (i) Without replacement.
    - (ii) With replacement.
2. A cupboard has 7 white cups and 5 brown cups all identical in size and shape. There is a blackout in the town and Mrs. Bett has to select three cups one after another without replacing the previous ones.
  - (a) Draw a tree diagram for the information
  - (b) Calculate the probability that she chooses;
    - (i) Two white cups and one brown cup
    - (ii) Two brown cups and one white cup
    - (iii) At least one white cup
    - (iv) three cups of the same colour
3. A two digit number is formed from the first four prime numbers.
  - a) Draw the table to show the possible outcomes, if each number can be used only once.
  - b) Calculate the probability that a number chosen from the digit numbers is an even number
4. The probability that a boy goes to school by bus is  $\frac{1}{3}$  and by matatu is  $\frac{1}{2}$ . If he uses a bus, the probability that he is late to school is  $\frac{1}{5}$  and if he uses a matatu, the probability of being late is  $\frac{3}{10}$ . If he uses other means of transport, the probability of being late is  $\frac{1}{20}$ 
  - (a) Draw a probability tree diagram to represent this information
  - (b) What is the probability that he will be late for school
  - (c) What is the probability that he be late for school if he does not use a matatu
  - (d) What is the probability that he is not late for school
5. One day during inspection in a certain secondary school, it was discovered that there was a probability of  $\frac{2}{5}$  that a students had shaggy hair, if a student had shaggy hair, there was a probability of  $\frac{1}{2}$  that he had torn uniform. But if he had properly combed hair, there was a probability of  $\frac{1}{4}$  that he had a torn uniform. If a student had torn uniform there was a probability of  $\frac{4}{5}$  that he had unpolished shoes. Otherwise there was a probability of  $\frac{3}{5}$  that he had polished shoes.
  - a) Represent this information in a probability tree diagram
  - b) Find the probability that:-
    - i) a student had all the three faults

- ii) a student had exactly two faults
- iii) a student had no faults at all

6. A shop is stocked with plates which are from two suppliers **A** and **B**. They are brought in the ratio of 3:5 respectively. 10% of plates from **A** are defective and 6% of plates from **B** are defective.
7. In a science class  $\frac{2}{3}$  of the class are boys and the rest are girls. 80% of the boys and 90% of the girls are right handed and the rest are left handed. The probability that a right handed student will break a test-tube in any session is  $\frac{1}{10}$  and the corresponding for the left handed student is  $\frac{3}{10}$ , their probability being independent of the student sex.
- a) Complete the probability tree diagram given below

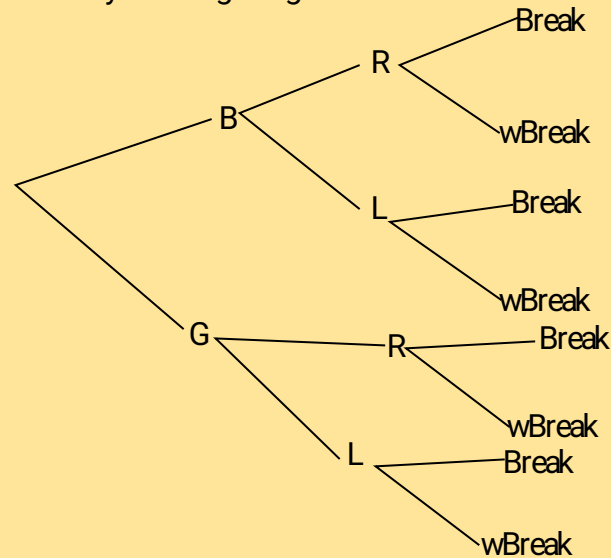

- b) Using the tree diagram, find the probability that :
- i) A student chosen from the class is left handed
  - ii) A test-tube is broken by a left handed student
  - iii) A test-tube is broken by a right handed student
  - iv) A test-tube is not broken in any session
8. Students who performed well in an examination are to be given an outing. A student has to throw two dice. If he gets a sum greater than 8, he gets a two-days outing, otherwise he gets a one day outing.
- (a) Find the probability that a student gets a two-day outing
  - (b) A student who qualifies for a two-day outing throws a die and a coin to decide whether he gets pocket money for the two days or for only one day. If he gets a head and a multiple of 3 he gets pocket money for two days. Find the probability that he is given a two-day outing but given pocket money for only one day
  - (c) If a student gets a one-day outing, he throws a die to decide if he gets pocket money or not. If he gets a number greater than 4 he gets the pocket money. Find the probability that:-
    - (i) A student gets pocket money for two days
    - (ii) A student gets pocket money
9. A bag contains 6 red beads and 4 white ones. Two beads are selected from the bag at random without replacement.
- (a) Draw a tree diagram to represent the above information.
  - (b) Calculate the probability that:
    - (i) Both beads are white.
    - (ii) Both beads are of the same colour.
    - (iii) At least a red bead is picked.
    - (iv) The two beads are of different colours.

10. A bag contains blue, green and red pens of the same type in the ratio 8:2:5 respectively. A pen is picked at random without replacement and its colour noted.
- Determine the probability that the first pen picked is;
    - blue
    - either green or red.
  - Using a tree diagram, determine the probability that;
    - the first two pens picked are both green.
    - Only one of the first two pens picked is red.
- c) (i) Draw the probability space for the possible outcomes when a coin is tossed and a die thrown simultaneously  
 (ii) Determine the probability of getting a head and an even number.
11. A box contains five red balls and four black balls all identical. Three balls are drawn without replacement from the box at random;
- Draw a tree diagram to show the situation
  - use the tree diagram to find the probability that;
    - the balls picked are of the same colour
    - more red balls were picked
    - at least a black ball was picked
    - atmost 1 red ball was picked
12. A bag contains 10 balls of which 3 are red, 5 are white and 2 are green. Another bag contains 12 balls of which 4 are red, 3 are white and 5 are green. A bag is chosen at random and then a ball chosen at random from the bag. Find the probability that the ball so chosen is red
13. In a certain science class  $\frac{2}{3}$  of the class are boys and the rest girls.  $\frac{4}{5}$  of the boys and  $\frac{9}{10}$  of the girls are right handed, and the rest are left handed. The probability that a right handed student will break a test-tube in any session is  $\frac{1}{10}$  and the corresponding probability for a left handed student is  $\frac{3}{10}$ , these probabilities being independent of the student's sex.
- Represent this information on a tree diagram
  - Using the diagram above;
    - determine the probability that a student chosen at random from the class is left handed
    - determine the probability that a student chosen at random from the class is right handed and will break a test tube in any session
  - determine the probability that a test tube is broken in any session
14. A box contains 5 red biro pens, 4 black biro pens and 6 green biro pens. If three pens are picked once at random, find the probability that:
- all the biro pens are red
  - the biro pens are of the same colour
  - the biro pens are one of each colour
  - none of the biro pens is red
15. The probability that Chebet goes to bed on time  $\frac{3}{4}$ . If she goes to bed on time, the probability that she wakes up on time is  $\frac{5}{6}$ , otherwise her probability of waking up on time is  $\frac{1}{3}$ .
- (i) Find the probability of Chebet getting to bed on time and waking up on time by use of diagram  
 (ii) Waking up late
  - If Chebet wakes up late, her probability of getting to class on time is  $\frac{1}{5}$  otherwise, her probability of getting to class on time is  $\frac{3}{5}$ .
    - Find the probability of Chebet getting to bed on time and gets to class late
    - Getting to bed late and get to class on time

### 53. Compound proportions, mixtures and rates of work

1. Three business partners Georgina, Gilbert and Akumu decided to buy a plot worth shs.510,000. They contributed shs.30000; as a deposit in the ratio 2:3:5 respectively. They paid the balance in two months by contributing equal amounts. After one year, they sold the plot for a profit of 20% and invested the initial capital in another business. The profit was shared in the ratio 1:2:3; respectively. Find how much each partner
  - (a) contributed towards the deposit
  - (b) paid to clear the balance
  - (c) received as a profit
2. Twelve men take 20days to complete a piece of work. How long would 16 men take to do the same piece of work?
3. Mr. Kitur bought grades of tea ; Grade A costs shs.109 per kg and a kg of Grade B costs shs.81.50. In what ratio must he mix the two grades in order to make a profit of 20% by selling the mixture at Kshs.112.80per kg?
4. Mogutu and Onacha working together can do a piece of work in 6days. Mogutu working alone takes 5days longer than Onacha. How many days does it take Onacha to do the work alone?
5. Given the curve  $y = 2x^3 + \frac{1}{2}x^2 - 4x + 1$ , find the equation of the normal to the curve at  $(1, -\frac{1}{2})$
6. **A** and **B** are connected by the equation  $B = KA + M$  where **K** and **M** are constants. The table below shows the values of **A** and corresponding values of **B**

A	1.5	3.0	4.5	6.0	7.5
B	8	11	14	17	20

- a) Draw a suitable straight line on the grid provided
  - b) State the values of **K** and **M**, hence express **B** in terms of **A**
7. The latitude and longitude of two stations **P** and **Q** are  $(47^\circ\text{N}, 25^\circ\text{W})$  and  $(47^\circ\text{N}, 70^\circ\text{W})$  respectively. Calculate the distance in nautical miles between **P** and **Q** along the latitude  $47^\circ\text{N}$
  8. A coffee blender mixes 6 parts of types **A** with 4 parts of type **B**. If type **A** costs Kshs. 72 and type **B** costs him Ksh.66 per kg respectively at what price should he sell the mixture in order to make a profit of 5%. Give your answer to the nearest ten cent.
  9.
    - (a) (i) Paint **A** costs shs.150 per litre while **B** costs shs.160 per litre. In what proportion must **A** be mixed with **B** to produce a mixture costing shs.156 per litre
    - (ii) What must be the selling price of the mixture if a profit of 12% is to be realized?
    - (b) A cylindrical water tank can be filled to a depth of 2.1m by a pipe **P** in 2 hours. Pipe **Q** takes 7 hours to fill the tank to the same level. Pipe **R** can empty this amount of water in 6hours. Initially, the tank is empty. Pipes **P** and **Q** are turned on at 8.45a.m and pipe **R** at 9.45a.m. Find the depth of water in the tank at 11.45a.m
  10. Two grades of tea leaves one costing sh.420 per kilogram and the other costing sh. 470 per kilogram are to be mixed in order to produce a blend worth sh.455 per kilogram. In what proportion should they be mixed?
  11. The internal radius of a pipe is 0.35m. Water flows through the pipe at the rate of 45cm per second. Calculate the amount of water that passes through the pipe in  $2\frac{1}{4}$  hours in litres
  12. In 2000 the total cost of manufacturing an item was ksh1250 and this was divided among the costs of material, labour and transport in the ratio of 8:14:13. In 2003 the cost of material



was doubled, labour cost increased by 30% and transport costs increased by 20%

a) Calculate the cost of manufacturing this item in 2003

b) In 2004 the cost of manufacturing the same item was Ksh1981 as a result of increase in labour costs only. Find the percentage increase in labour costs of 2004

13. Brand **A** tea costing Kshs.80 per kg is mixed with Brand **B** tea costing Kshs.100 per kg such that the mixture is sold at Kshs.114 making a profit of 20%. Find the ratio of **A:B**
14. In what proportion must teas of Kshs.76 and Kshs.84 per kg be mixed to produce a tea costing Kshs.81 per kg
15. Onyango bought 3 brands of tea **P**, **Q** and **R**. the cost price of the three brands were shs.25, shs.30 and shs.45 per kilogram respectively. He mixed the three brands in the ratio 5:2:1 respectively After selling the mixture, he made a profit of 20%
- (a) How much, profit did he make per kilogram of the mixture?
- (b) After one year, the cost price each brand was increased by 12%.
- (i) For how much did he sell one kilogram of the mixture to maintain 20% profit. Give your answers to the nearest 5cts.
- (ii) What would have been his percentage profit if he sold one kilogram of the mixture at shs.40.25?
16. A mixture contains two powders X and Y with masses in the ratio 3:11. If the mixture Cost Shs.6.70 per kg and powder x costs Shs.5.60 per kg. Find the cost of 1kg of powder Y

#### 54. Graphical Methods

1. The equation of a circle is given by  $x^2 + 4x + y^2 - 5 = 0$ . Find the centre of the circle and its radius.
2. The equation of a circle is  $x^2 + y^2 + 6x - 10y - 2 = 0$ . Determine the co-ordinates of the centre of the circle and state its radius
3. In the diagram below ABE is a tangent to a circle at B and DCE is a straight line. If  $\angle ABD = 60^\circ$ ,  $\angle BOC = 80^\circ$  and O is the centre of the circle, find with reasons  $\angle BEC$

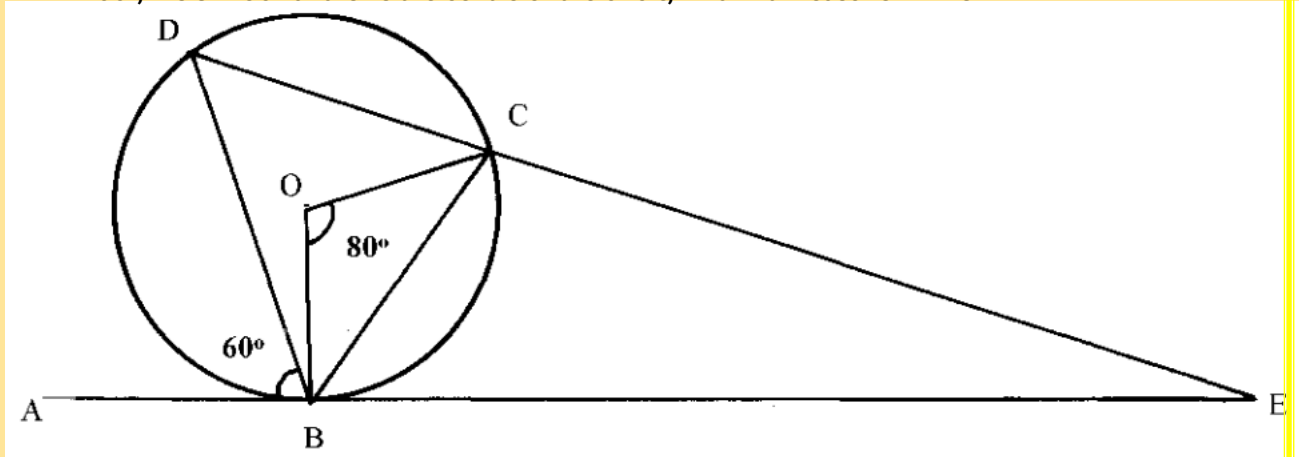

4. Obtain the centre and the radius of the circle represented by the equation:  
 $x^2 + y^2 - 10y + 16 = 0$
5. Complete the table below, for the function  $y = x^3 + 6x^2 + 8x$



x	-5	-4	-3	-2	-1	0	1
$x^3$	-125		-27	-8		0	1
$6x^2$		96	54		6	0	6
$8x$	-40		-24			0	8
y			3	0		0	15

(a) Draw a graph of the function  $y = x^3 + 6x^2 + 8x$  for  $-5 \leq x \leq 1$  and use the graph to estimate the roots of the equation  $x^3 + 6x^2 + 8x = 0$

(b) Find which values of  $x$  satisfy the inequality  $x^3 + 6x^2 + 8x - 1 > 0$

6. Sketch the curve of the function  $y = x^3 - 3x + 2$  showing clearly minimum and maximum points and the  $y$  - intercept.

7. Show that  $4y^2 + 4x^2 = 12x - 12y + 7$  is the equation of a circle, hence find the co-ordinates of the centre and the radius

8. Two variables  $R$  and  $P$  are connected by a function  $R = KP^n$  where  $K$  and  $n$  are constants. The table below shows data involving the two variables

P	3	3.5	4	4.5	5
R	36	49	64	81	100

(a) Express  $R = KP^n$  in a linear form

(b) Draw a line graph to represent the information above

(c) Find the values of constants  $K$  and  $n$

(d) Write down the law connecting  $R$  and  $P$

(e) Find the value of  $P$  when  $R = 900$

9. A circle of radius 3cm has the centre at  $(-2, 3)$ . Find the equation of the circle in the form of  $x^2 + y^2 + Px + Qy + c = 0$

10. In an experiment, the values of two quantities  $V$  and  $T$  were observed and the results recorded as shown below.

V	0	2	4	6	8	10
T	0.49	0.30	0.24	0.20	0.16	0.13 7

It is known that  $T$  and  $V$  are related by a law of the form  $T = a \frac{\quad}{b + V}$

where  $a$  and  $b$  are constants.

a) Draw the graph of  $\frac{1}{T}$  against  $V$

b) Use your graph to find;

i) The values of  $a$  and  $b$ .

ii)  $V$  when  $T = 0.38$

iii)  $T$  when  $V = 4.5$

11. Find the equation of the tangent to the curve  $y = 2x^3 + x^2 + 3x - 1$  at the point  $(1, -5)$  expressing your answer in the form  $y = mx + c$

12. Given that :-  $243 = (81)^{-1} \times \left(\frac{1}{27}\right)^x$  determine the value of  $x$

13. Show that  $3x^2 + 3y^2 + 6x - 12y - 12 = 0$  is an equation of a circle hence state the radius and centre of the circle

14. (a) Fill in the table below for the function  $y = -6 + x + 4x^2 + x^3$  for  $-4 \leq x \leq 2$

$x$	-4	-3	-2	-1	0	1	2
-6	-6	-6	-6	-6	-6	-6	-6
$x$	-4	-3	-2	-1	0	1	2
$4x^2$			16			4	
$x^3$							
$y$							

(b) Using the grid provided draw the graph for  $y = -6 + x + 4x^2 + x^3$  for  $-4 \leq x \leq 2$

(c) (i) Use the graph to solve the equations:-

(i)  $x^3 + 4x^2 + x - 4 = 0$

(ii)  $-6 + x + 4x^2 + x^3 = 0$

(iii)  $-2 + 4x^2 + x^3 = 0$

15. The table below shows the results obtained from an experiment to determine the relationship between the length of a given side of a plane figure and its perimeter

Length of side $l$ (cm)	1	2	3	4	5
Perimeter $P$ (cm)	6.28	12.57	18.86	21.14	31.43

(a) On the grid provided, draw a graph of perimeter  $P$ , against  $l$

(b) Using your graph determine;

(i) the perimeter of a similar figure of side 2.5cm

(ii) the length of a similar figure whose perimeter is 9.43cm

(iii) the law connecting perimeter  $p$  and the length  $l$

(c) If the law is of the form  $P = 2kl + c$  where  $k$  and  $c$  are constants, find the value of  $k$

16. In an experiment with tungsten filament lamp, the reading below of voltage (V) current (I), power (P) and resistance (R) were obtained. It was established that  $P$  was related to  $R$  by a law  $P = aR^n - 0.6$ . Where  $a$  and  $n$  are constants.

<b>V</b>	1.30	2.00	2.80	4.40	5.70
<b>I</b>	1.50	1.80	2.10	2.50	2.90
<b>P</b>	0.73	2.05	3.28	7.44	10.62
<b>R</b>	0.89	1.13	1.33	1.78	1.99

Plot a suitable line graph and hence use it to determine the value of  $a$  and  $n$

17. Find the gradient of a line joining the centre of a circle whose equation is  $x^2 + y^2 - 6x = 3 - 4y$  and a point  $P(6,7)$  outside the circle..

18. a) Complete the table below for the function  $y = -x^3 + 2x^2 - 4x + 2$ .

<b>x</b>	-3	-2	-1	0	1	2	3	4
$-x^3$	27	8		0		-8		
$2x^2$	18	8	2	0				
$-4x$		8		0				-16
2	2	2	2	2	2	2	2	2
$y$		26		2		-6		-46

b) On the grid provided below draw the graph of  $-x^3 + 2x^2 - 4x + 2$  for  $-3 \leq x \leq 4$ .

c) Use the graph to solve the equation  $-x^3 + 2x^2 - 4x + 2 = 0$ .

d) By drawing a suitable line on the graph solve the equation.  $-x^3 + 2x^2 - 5x + 3 = 0$ .

19. Determine the turning point of the curve  $y = 4x^3 - 12x + 1$ . State whether the turning point is a maximum or a minimum point.

20. (a) Complete the table below for the equation of the curve given by  $y = 2x^3 - 3x^2 + 1$

X	-2	-1.5	-1	-0.5	0	0.5	1	1.5	2	2.5	3
$2x^3$	-16		-2		0		2		16		
$-3x^2$	-12			0.75	0	-0.75					-27
1	1				1						
y	-27	-12.5			1						13.5

(b) Use the table to draw the graph of the function  $y = 2x^3 - 3x^2 + 1$

c) Use your graph to find the values of x for :-

(i)  $y > 0$

(ii) The roots of the equation  $2x^3 - 3x^2 + 1 = 0$

(iii)  $2x^3 - 3x^2 = 9$

21. Find the radius and the centre of a circle whose equation is :

$$2x^2 + 2y^2 - 6x + 10y + 9 = 0$$

## 55. Matrices and Transformations

1. Given triangle ABC with vertices A (-6, 5), B(-4, 1) and C(3, 2) and that A(-6, 5) is mapped onto  $A^1(-6, -4)$  by a shear with y-axis in variant. On the grid provided below;

(i) draw triangle ABC

(ii) draw triangle  $A^1B^1C^1$ , the image of triangle ABC, under the shear

(iii) determine the matrix representing the shear

(b) Triangle  $A^1B^1C^1$  is mapped onto  $A^{11}B^{11}C^{11}$  by a transformation defined by the matrix

(i) Draw triangle  $A^{11}B^{11}C^{11}$  on the same grid as ABC and  $A^1B^1C^1$

(ii) Describe fully a single transformation that maps  $A^{11}B^{11}C^{11}$

$$\begin{pmatrix} -1 & 0 \\ 3/2 & -1 \end{pmatrix}$$

2. (a) Under a certain rotation A(2,0) is mapped onto  $A^1(-4, 2)$  and B(0,5) is mapped onto  $B^1(-9, 0)$

(i) On the grid provided plot the lines AB and  $A^1B^1$  on the same axes

(ii) Hence determine by construction the co-ordinates of the centre and angle of rotation

(b) Under a quarter positive turn about the origin O,  $A^1$  is mapped onto  $A^{11}$  and  $B^1$  is mapped onto  $B^{11}$ . Determine the co-ordinates of  $A^{11}$  and  $B^{11}$

(c) Describe fully a single transformation which would map A to  $A^{11}$  and B to  $B^{11}$

3. A transformation T is represented by the matrix  $\begin{pmatrix} 0 & 1 \\ -1 & 0 \end{pmatrix}$  and transformation U  $\begin{pmatrix} 0 & 1 \\ -1 & 0 \end{pmatrix}$  by the

matrix. Given that a rectangle has co-ordinates at A (1,2) B(6, 2), C(6, 4) and D (1, 4) and that under T the image of ABCD is  $A_1B_1C_1D_1$  and under U the image of  $A_1B_1C_1D_1$  is  $A_2B_2C_2D_2$ :

(a) Find the co-ordinates of  $A_1B_1C_1D_1$  and  $A_2B_2C_2D_2$

(b) On the grid provided, plot ABCD,  $A_1B_1C_1D_1$  and  $A_2B_2C_2D_2$

(c) Describe the transformation represented by:-

(i) U

(ii) UT

(d) If  $A_2B_2C_2D_2$  were to be transformed by a transformation represented by the matrix to map onto  $A_3B_3C_3D_3$ . What would be the area of  $A_3B_3C_3D_3$

4. The vertices of a quadrilateral are A(2,2) B(8,2), C (8,6) and D(6,4) under a rotation the images of vertices A and D are  $A^1(0,8)$  and  $D^1(-2, 12)$ .

(a) On the grid provided and using the same axes draw the quadrilateral ABCD and the points  $A^1$  and  $D^1$

(b) Determine the centre and angle of rotation

(c) Locate the points  $B^1$  and  $C^1$  under the rotation and complete the quadrilateral

5. A translation maps the point  $P(5, -3)$  onto  $P^1(2, -5)$   
 (a) Determine the translation vector  $T$   
 (b) A Point  $R^1$  is the image of  $R(-2, -3)$  under the same translation in (a) above, find the magnitude of  $P^1R^1$
6. Triangle ABC has vertices at  $A(0, -1)$ ,  $B(4, 3)$  and  $C(2, 2)$ .  
 (a) Find the coordinates of image triangle  $A^1B^1C^1$  of triangle ABC under translation vector  $\begin{pmatrix} 1 \\ 2 \end{pmatrix}$   
 (b) Given that triangle  $A^{11}B^{11}C^{11}$  is the image of triangle  $A^1B^1C^1$  under an enlargement scale factor 3, centre  $O(0,0)$ , find the coordinates of  $A^{11}$ ,  $B^{11}$  and  $C^{11}$   
 (c) If the area of triangle  $A^1B^1C^1$  is  $24 \text{ cm}^2$ , calculate the area of triangle  $A^{11}B^{11}C^{11}$   
 (d) Find the matrix that maps triangle  $A^{11}B^{11}C^{11}$  onto triangle ABC
7. a) The triangle ABC where  $A(2, -1)$ ,  $B(1, 2)$  and  $C(4, 4)$  is reflected in the line  $X = 4$  to give triangle  $A_1B_1C_1$ . Draw the two triangles on the graph provided and state the co-ordinates of  $A_1B_1C_1$   
 b) Draw the triangle  $A_2(5, 6)$ ,  $B_2(2, 7)$  and  $C_2(0, 4)$ . Given that triangle  $A_2B_2C_2$  is the image of triangle  $A_1B_1C_1$  under rotation, determine the centre and angle of this rotation  
 c) Show the image of triangle  $A_2B_2C_2$  under an enlargement centre  $(0, 6)$  scale factor  $-1$
8. (a) Find the co-ordinates for the image of point  $P(6, -2)$  under the transformation defined by :-  
 $x^1 = x - 3y$   
 $y^1 = 2x$   
 (b) (i) A quadrilateral ABCD has vertices  $A(4, -3)$ ,  $B(2, -3)$ ,  $C(4, -1)$  and  $D(5, -4)$ . On the grid provided, draw the quadrilateral ABCD  
 (ii)  $A^1B^1C^1D^1$  is the image of ABCD under a rotation through  $+90^\circ$  about the origin. On the same axes, draw  $A^1B^1C^1D^1$  under the transformation  
 (c)  $A^2B^2C^2D^2$  is the image of  $A^1B^1C^1D^1$  under another transformation by the matrix  $\begin{pmatrix} 1 & -2 \\ 0 & 1 \end{pmatrix}$   
 (i) Determine the co-ordinates of  $A^2B^2C^2D^2$  and plot it on the same axes  
 (ii) Describe the transformation that maps  $A^1B^1C^1D^1$  onto  $A^2B^2C^2D^2$   
 (d) Find a single matrix of transformation that would map  $A^2B^2C^2D^2$  onto ABCD
9. (a) Triangle XYZ has vertices  $X(2, -1)$ ,  $Y(4, -1)$  and  $Z(4, 2)$ . Triangle XYZ maps onto triangle  $X^1Y^1Z^1$  under transformation  $T_1 = \begin{pmatrix} 1 & -3 \\ 1 & 1 \end{pmatrix}$ . Draw triangles XYZ and its image  $X^1Y^1Z^1$  on the grid provided  
 (b) Another triangle  $X^{11}Y^{11}Z^{11}$  is the image of  $X^1Y^1Z^1$  after transformation  $T_2 = \dots$ . Draw triangle  $X^{11}Y^{11}Z^{11}$  on the same set of axes  
 (c) Find the single transformation matrix  $T$  that maps triangle XYZ on to the final image  $X^{11}Y^{11}Z^{11}$   
 (d) Given that the area of triangle XYZ is  $15 \text{ cm}^2$ , find the area of the triangle  $X^{11}Y^{11}Z^{11}$
10. The quadrilateral A  $(2, 1)$ , B  $(4, 1)$ , C  $(4, 4)$  and D  $(2, 4)$  is mapped onto  $A'B'C'D'$  by a matrix  $M_1$  such that  $A^1(8, 7)$ ,  $B^1(14, 7)$ ,  $C^1(14, 16)$  and  $D^1(8, 16)$ .  
 a) Draw both ABCD and  $A^1B^1C^1D^1$  on the same plane  
 b) Find the matrix of transformation that mapped ABCD onto  $A'B'C'D'$  and describe it fully  
 c)  $A^1B^1C^1D^1$  underwent another matrix transformation at N which is a translation that gave the image  $A^{11}B^{11}C^{11}D^{11}$ , Where  $A^{11}(7, 9)$ ,  $B^{11}(13, 9)$ ,  $C^{11}(13, 18)$  and  $D^{11}(7, 18)$ . The transformation N is a translation. Find the translation  
 d) Draw  $A^{11}B^{11}C^{11}D^{11}$  on the same axes where ABCD and  $A^1B^1C^1D^1$  were drawn
11. a) On the grid provided. Plot the points  $A(2, -1)$ ,  $B(0, -3)$ ,  $C(2, -4)$  and  $D(4, -2)$  and join them to form a quadrilateral ABCD. What is the name of this quadrilateral?  
 b) The points  $A^1(1, 2)$ ,  $B^1(3, 0)$ ,  $C^1(4, 2)$  and  $D^1(2, 4)$  are the images of ABC and D under a certain transformation  $T_1$ . On the same grid draw quadrilateral  $A^1B^1C^1D^1$  and describe transformation  $T_1$  fully.

- c) The points  $A^{11}(-2, -4)$   $B^{11}(-6, 0)$   $C^{11}(-8, -4)$  and  $D^{11}(-4, -8)$  are the images of  $A^1B^1C^1D^1$  under transformation  $T_2$ . On the same grid draw quadrilateral  $A^{11}B^{11}C^{11}D^{11}$  and describe the transformation  $T_2$  fully.
- d) On the same grid draw quadrilateral  $A^{111}B^{111}C^{111}D^{111}$ , the image of  $A^{11}B^{11}C^{11}D^{11}$  under a reflection in the x-axis. State the co-ordinates of  $A^{111}B^{111}C^{111}D^{111}$ .

12. The Points  $A^1B^1$  and  $C^1$  are the images of  $A(4, 1)$ ,  $B(0, -2)$  and  $C(-2, 4)$  respectively under a transformation represented by the matrix;

$$M = \begin{pmatrix} 1 & 1 \\ 2 & -3 \end{pmatrix}$$

(a) Write down the coordinates of  $A^1 B^1$  and  $C^1$

(b)  $A^{11} B^{11}$  and  $C^{11}$  are the images of  $A^1 B^1$  and  $C^1$  under another transformation whose Matrix is:

$$N = \begin{pmatrix} 2 & 1 \\ 1 & 2 \end{pmatrix} \begin{matrix} 1 \\ 2 \end{matrix} \quad \text{Write down the coordinates of } A^{11} B^{11} \text{ and } C^{11}$$

(c) Transformation **M** followed by **N** can be represented by a single transformation **P**. Determine the matrix for **P**

(d) A matrix **P** is given by  $\begin{pmatrix} 8 & 7 \\ 4 & 5 \end{pmatrix}$   
Find  $P^{-1}$

13. Triangle  $A^1B^1C^1$  is the image of triangle  $ABC$  under a transformation represented by matrix  $T = \begin{pmatrix} 1 & 3 \\ 2 & 2 \end{pmatrix}$ . If the area of triangle  $A^1B^1C^1$  is  $25.6\text{cm}^2$ , find the area of the object

14. A point  $P(2, -4)$  is mapped into  $P^1(4, 0)$  under a translation. Determine the image of point  $Q(-1, 2)$  under the same translation

15. The points  $A(2, 6)$ ,  $B(1, 1)$ ,  $C(2, 3)$  and  $D(4, 0)$  are the vertices of quadrilateral  $ABCD$ .  
(a) On graph paper plot the points  $A, B, C,$  and  $D$  and join them to form quadrilateral  $ABCD$ .

(b) The points  $A, B, C$  and  $D$  are the images of  $A^1, B^1, C^1$  and  $D^1$  respectively under an enlargement centre the origin and scale factor  $-2$ . On the same grid draw the image quadrilateral  $A^1 B^1 C^1 D^1$ .

(c) The points  $A^{11} B^{11} C^{11}$  and  $D^{11}$  are the images of  $ABCD$  respectively under reflection in the  $x - \text{axis}$ . On the same grid, locate the points  $A^{11} B^{11} C^{11}$  and  $D^{11}$  and draw the second image quadrilateral  $A^{11} B^{11} C^{11} D^{11}$ .

(d) Quadrilateral  $A^{111} B^{111} C^{111} D^{111}$  is the image of  $ABCD$  under a certain transformation  $T$ . Describe transformation  $T$  fully.

$$\begin{pmatrix} 5x & 2 \\ x & -3 \end{pmatrix}$$

16.  $T$  is a transformation represented by the matrix  $\begin{pmatrix} 5x & 2 \\ x & -3 \end{pmatrix}$ . Under  $T$ , a square of area  $10\text{cm}^2$  is mapped onto a square  $110\text{cm}^2$ . Find the values of  $x$

## 56. Statistics II

1. The table below shows the masses to the nearest kg of a number of people.

Mass (kg)	50 – 54	55 – 59	60 – 64	65 – 69	70 – 74	75 – 79	80 – 84
Frequency	19	23	40	28	17	9	4

a) Using an assumed mean of  $67.0$ , calculate to one decimal place the mean mass.

(b) Calculate to one decimal place the standard deviation of the distribution.

2. Use only a ruler and pair of compasses in this question;

- (a) construct triangle ABC in which  $AB = 7\text{cm}$ ,  $BC = 6\text{cm}$  and  $AC = 5\text{cm}$
- (b) On the same diagram construct the circumcircle of triangle ABC and measure its radius
- (c) Construct the tangent to the circle at C and the internal bisector of angle BAC. If these lines meet at D, measure the length of AD

3. Below is a histogram drawn by a student of Got Osimbo Girls Secondary School.

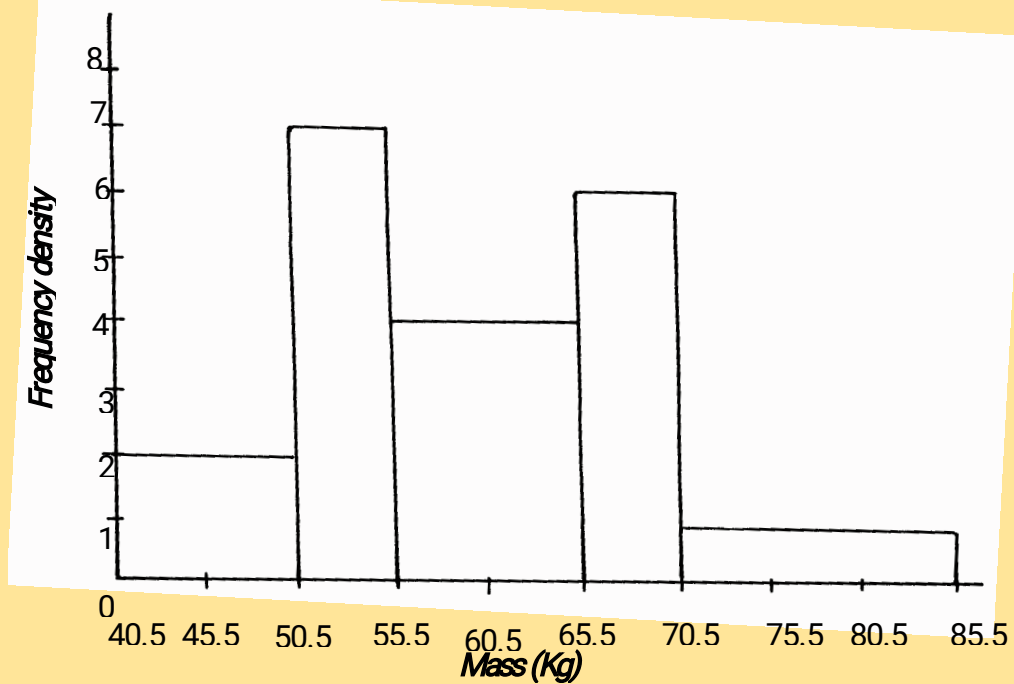

- a) Develop a frequency distribution table from the histogram above.
- b) Use the frequency distribution table above to calculate;
  - i) The inter-quartile range.
  - ii) The sixth decile.

4. ABC is a triangle drawn to scale. A point x moves inside the triangle such that

- i)  $AX \leq 4\text{ cm}$
- ii)  $BX > CX$
- iii)  $\text{Angle } BCX \leq \text{Angle } XCA$ .

Show the locus of X.

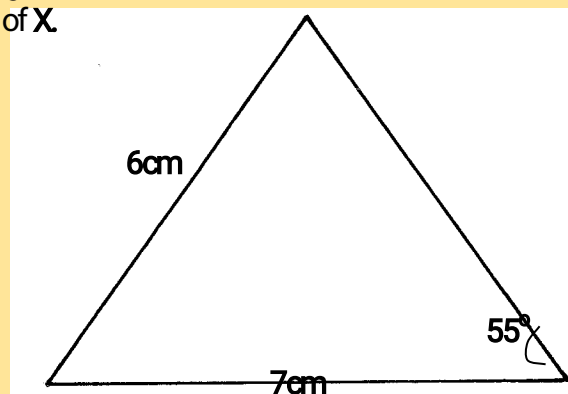

5. The following table shows the distribution of marks of 80 students

Marks	1-10	11-20	21-30	31-40	41-50	51-60	61-70	71-80	81-90	91-100
Frequency	1	6	10	20	15	5	14	5	3	1

- (a) Calculate the mean mark
- (b) Calculate the semi-interquartile range
- (c) Workout the standard deviation for the distribution





6. The table below shows the marks of 90 students in a mathematical test

Marks	5-9	10-14	15-19	20-24	25-29	30-34	35-39
No. of students	2	13	31	23	14	X	1

- a) Find X  
 b) State the modal class  
 (c) Using a working mean of 22, calculate the; i) Mean mark  
 ii) Standard deviation

7. (a) Using a ruler and a pair of compasses only construct triangle PQR in which PQ = 5cm, PR = 4cm and  $\angle PQR = 30^\circ$

- (b) Measure; (i) RQ  
 (ii)  $\angle PQR$

(c) Construct a circle, centre O such that the circle passes through vertices P, Q, and R (d)

Calculate the area of the circle

8. The ages of 100 people who attended a wedding were recorded in the distribution table below

Age	0-19	20-39	40-59	60-79	80-99
Frequency	7	21	38	27	7

- a) Draw the cumulative frequency  
 b) From the curve determine: i) Median  
 ii) Inter quartile range  
 iii) 7<sup>th</sup> Decile  
 iv) 60<sup>th</sup> Percentile

9. The marks obtained by 10 students in a maths test were:-  
 25, 24, 22, 23, x, 26, 21, 23, 22 and 27

The sum of the squares of the marks,  $\sum x^2 = 5154$

- (a) Calculate the: (i) value of x  
 (ii) Standard deviation  
 (b) If each mark is increased by 3, write down the:-  
 (i) New mean  
 (ii) New standard deviation

10. 40 form four students sat for a mathematics test and their marks were distributed as follows:-

Marks	1 - 10	11-20	21-30	31 -40	41 - 50	51 - 60	61 - 70	71 - 80	81 - 90	91 - 100
No. of students	1	3	4	7	12	9	2	1	0	1

- a) Using 45.6 as the working mean, calculate;  
 i) The actual mean.  
 ii) The standard deviation.  
 b) When ranked from first to last, what mark was scored by the 30<sup>th</sup> student?  
 (Give your answer correct to 3 s.f.)

11. The table below shows the distribution of marks scored by pupils in a maths test at Nyabisawa Girls.

Marks	11 - 20	21 - 30	31 - 40	41 - 50	51 - 60	61 - 70	71 - 80	81 - 90
Frequency	2	5	6	10	14	11	9	3

- a) Using an Assumed mean 45.5, calculate the mean score.

- b) Calculate the median mark.
- c) Calculate the standard deviation.
- d) State the modal class.

12. The table below shows the marks scored in a mathematics test by a form four class;

Marks	20-29	30-39	40-49	50-59	60-69	70-79	80-89
No. of students	4	26	72	53	25	9	11

- (a) Using an assumed mean of 54.5, calculate:-
  - (i) The mean
  - (ii) The standard deviation
- (b) Calculate the inter quartile range

### 57. Loci

1.
  - (a) Using a ruler, a pair of compasses only construct triangle XYZ such that  $XY = 6\text{cm}$ ,  $YZ = 8\text{cm}$  and  $\angle XYZ = 75^\circ$
  - (b) Measure line XZ and  $\angle XZY$
  - (c) Draw a circle that passes through X, Y and Z
  - (d) A point M moves such that it is always equidistant from Y and Z. construct the locus of M and define the locus
2.
  - (a) (i) Construct a triangle ABC in which  $AB=6\text{cm}$ ,  $BC = 7\text{cm}$  and angle  $ABC = 75^\circ$   
**Measure:-**
    - (i) Length of AC
    - (ii) Angle ACB
  - (b) Locus of P is such that  $BP = PC$ . Construct P
  - (c) Construct the locus of Q such that Q is on one side of BC, opposite A and angle  $BQC = 30^\circ$
  - (d) (i) Locus of P and locus of Q meet at X. Mark **x**
  - (ii) Construct locus R in which angle  $BRC = 120^\circ$
  - (iii) Show the locus S inside triangle ABC such that  $XS \geq SR$
3. *Use a ruler and compasses only for all constructions in this question.*
  - a) (i) Construct a triangle ABC in which  $AB=8\text{cm}$ , and  $BC=7.5\text{cm}$  and  $\angle ABC=112\frac{1}{2}^\circ$
  - (ii) Measure the length of AC
  - b) By shading the unwanted regions show the locus of P within the triangle ABC such that
    - i)  $AP \leq BP$
    - ii)  $AP > 3\text{cm}$
 Mark the required region as **P**
  - c) Construct a normal from C to meet AB produced at D
  - d) Locate the locus of **R** in the same diagram such that the area of triangle ARB is  $\frac{3}{4}$  the area of the triangle ABC.
4. On a line AB which is 10 cm long and on the same side of the line, use a ruler and a pair of compasses only to construct the following.
  - a) Triangle ABC whose area is  $20\text{ cm}^2$  and angle  $ACB = 90^\circ$
  - b) (i) The locus of a point P such that angle  $APB = 45^\circ$ .
  - (ii) Locate the position of P such that triangle APB has a maximum area and calculate this area.

5. A garden in the shape of a polygon with vertices A, B, C, D and E.  $AB = 2.5\text{m}$ ,  $AE = 10\text{m}$ ,  $ED = 5.2\text{m}$  and  $DC = 6.9\text{m}$ . The bearing of B from A is  $030^\circ$  and A is due east of E while D is due north of E, angle  $EDC = 110^\circ$ ,
- Using a scale of 1cm to represent 1m construct an accurate plan of the garden
  - A foundation is to be placed near to CD than CB and no more than 6m from A,
    - Construct the locus of points equidistant from CB and CD.
    - Construct the locus of points 6m from A
  - shade and label R, the region within which the foundation could be placed in the garden
    - Construct the locus of points in the garden 3.4m from AE.
    - Is it possible for the foundation to be 3.4m from AE and in the region?
6.
  - Using a ruler and compasses **only** construct triangle PQR in which  $QR = 5\text{cm}$ ,  $PR = 7\text{cm}$  and angle  $PRQ = 135^\circ$
  - Determine  $\angle PQR$
  - At P drop a perpendicular to meet QR produced at T d)
 Measure PT
- Locate a point A on TP produced such that the area of triangle AQR is equal to one and a half times the area of triangle PQR
  - Complete triangle AQR and measure angle AQR
7. Use ruler and a pair of compasses only in this question.
- Construct triangle ABC in which  $AB = 7\text{cm}$ ,  $BC = 8\text{cm}$  and  $\angle ABC = 60^\circ$ .
  - Measure (i) side AC (ii)  $\angle ACB$
  - Construct a circle passing through the three points A, B and C. Measure the radius of the circle.
  - Construct  $\triangle PBC$  such that P is on the same side of BC as point A and  $\angle PCB = \frac{1}{2} \angle ACB$ ,  $\angle BPC = \angle BAC$  measure  $\angle PBC$ .
8. Without using a set square or a protractor:-
- Construct triangle ABC in which BC is 6.7cm, angle ABC is  $60^\circ$  and  $\angle BAC$  is  $90^\circ$ .
  - Mark point D on line BA produced such that line AD = 3.5cm
  - Construct:-
    - A circle that touches lines AC and AD
    - A tangent to this circle parallel to line AD
- Use a pair of compasses and ruler only in this question;
- Draw acute angled triangle ABC in which angle CAB =  $37\frac{1}{2}^\circ$ , AB = 8cm and CB = 5.4cm. Measure the length of side AC (hint  $37\frac{1}{2}^\circ = \frac{1}{2} \times 75^\circ$ )
  - On the triangle ABC below.
    - On the same side of AC as B, draw the locus of a point X so that angle  $AXC = 52\frac{1}{2}^\circ$
    - Also draw the locus of another point Y, which is 6.8cm away from AC and on the same side as X
  - Show by shading the region P outside the triangle such that angle  $APC \geq 52\frac{1}{2}^\circ$  and P is not less than 6.8cm away from AC

### 58. Trigonometric ratios 3

1. The table below gives some values of  $y = \sin 2x$  and  $y = 2 \cos x$  in the range given.

(a) Complete

$x^\circ$	-225	-180	-135	-90	-45	0	45	90	135	180	225
$y = \sin 2x^\circ$	-1.0		1.0			0			-1.0		1.0
$y = 2 \cos x^\circ$	-1.4		-1.4			2.0			-1.4		-1.4

(b) On the same axes, draw the graphs of  $y = \sin 2x$  and  $y = 2 \cos x$ .

(c) Use your graph to find in values of  $x$  for which  $\sin 2x - 2 \cos x = 0$ .

(d) From your graph

(i) Find the highest point of graph  $y = \sin 2x$ .

(ii) The lowest point of graph  $y = 2 \cos x$ .

2. (a) Copy and complete the table below for  $y = 2 \sin(x+15)^\circ$  and  $y = \cos(2x-30)^\circ$  for  $0^\circ \leq x \leq 360^\circ$

$x$	0	30	60	90	120	150	180	210	240	270	300
$y = 2 \sin(x+15)$											
$y = \cos(2x-30)$											

(b) On the

same axis draw the graphs:

$y = 2 \sin(x+15)$  and  $y = \cos(2x-30)$  for  $0^\circ \leq x \leq 360^\circ$

(c) Use your graph to:

(i) State the amplitudes of the functions  $y = 2 \sin(x+15)$  and  $y = \cos(2x-30)$

(ii) Solve the equation  $2 \sin(x+15) - \cos(2x-30) = 0$

3. The diagram below shows a frustum of a square based pyramid. The base ABCD is a square of side 10cm. The top  $A^1B^1C^1D^1$  is a square of side 4cm and each of the slant edges of the frustum is 5cm

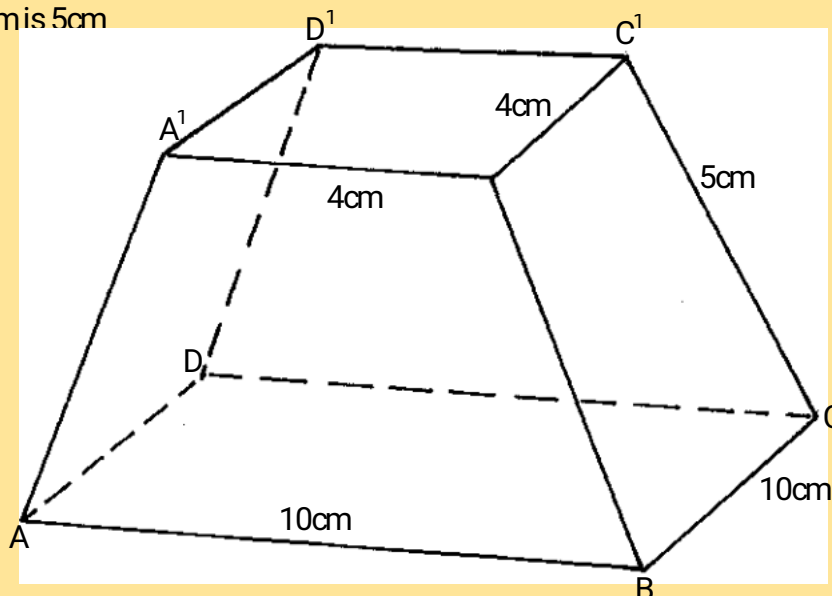

Determine the:

i) Altitude of the frustum

ii) Angle between  $AC^1$  and the base ABCD

iii) Calculate the volume of the frustum

4. (a) Complete the table below.

$$y = 3 \sin(2x + 15)^\circ$$

<b>x</b>	-180	-150	-120	-90	-60	-30	0	30	60	90	120
<b>y</b>	0.8			-0.8			0.8		21		

(b) Use the table to draw the curve  $y = 3\sin(2x+15)$  for the values  $-180^\circ \leq \theta \leq 120^\circ$

(c) Use the graph to find:

- (i) The amplitude
- (ii) The period
- (iii) The solution to the equation:-  
 $\sin(2x + 15)^\circ = 1/3$

5. Make **q** the subject of the formula in  $\frac{A}{B} = \sqrt{\frac{P+3q}{q-3p}}$

6. a) Complete the table below for the functions  $y = \cos(2x + 45)^\circ$  and  $y = -\sin(x + 30)^\circ$  for  $-180^\circ \leq x \leq 180^\circ$ .

	-180	-150	-120	-90	-60	-30	0	30	60	90	120	150	180
$y = \cos(2x + 45)^\circ$	0.71		-0.97	-0.71			0.71		-0.97			0.97	
$y = -\sin(x + 30)^\circ$	0.5	0.87			0.5			-0.87		-0.87			0.5

b) On the same axis, draw the graphs of  $y = \cos(2x + 45)^\circ$  and  $y = -\sin(x + 30)^\circ$

c) Use the graphs drawn in (b) above to solve the equation.

$$\cos(2x + 45)^\circ + \sin(x + 30)^\circ = 0$$

7. Without using tables or calculators evaluate  $\sin 60^\circ \cos 60^\circ$  leaving your answer in surd form  
 $\tan 30^\circ \sin 45^\circ$

8. (a) Complete the table below for the functions  $y = 3 \sin x$  and  $y = 2 \cos x$

<b>X</b>	0	30	60	90	120	150	180	210	240	270	300	330	360
$3\sin x$			2.6	3			0	-1.5	-2.6	-3		-1.5	
$2\cos x$		1.7	1.0			-1.7	-2	-1.0			1.0	1.7	2

(b) Using a scale of 2cm to represent 1 unit on the y-axis and 1cm to represent  $30^\circ$  on the x-axis, draw the graphs of  $y = 3\sin x$  and  $y = 2\cos x$  on the same axes on the grid provided

(c) From your graphs:

- (i) State the amplitude of  $y = 3\sin x$
- (ii) Find the values of  $x$  for which  $3\sin x - 2\cos x = 0$
- (iii) Find the range of values of  $x$  for which  $3\sin x \geq 2\cos x$

9. (a) Fill in the following table of the given function:-

<b>x</b>	0	90	180	270	360	450	540	630	720	810
$\sin \frac{1}{2}x$	0			0.71					0	
$3\sin(\frac{1}{2}x + 60)$					-2.6					2.6

(b) On the grid provided draw the graph of the function  $y = \sin \frac{1}{2}x$  and  $y = 3\sin(\frac{1}{2}x + 60)$  on the same set of axes

(c) What transformation would map the function  $y = \sin \frac{1}{2}x$  onto  $y = 3\sin(\frac{1}{2}x + 60)$

(d) (i) State the period and amplitude of function :  $y = 3\sin(\frac{1}{2}x + 60)$

(ii) Use your graph to solve the equation:  $3\sin(\frac{1}{2}x + 60) - \sin \frac{1}{2}x = 0$

10. a) Complete the table below giving your answer to 2 decimal places

$x^\circ$	$0^\circ$	$30^\circ$	$60^\circ$	$90^\circ$	$120^\circ$	$150^\circ$	$180^\circ$
$2\sin x^\circ$	0	1		2			
$1 - \cos x^\circ$			0.50	1			2

b) On the grid provided, using the same axis and scale draw the graphs of :-

$$y = 2\sin x^\circ, \text{ and } y = 1 - \cos x^\circ$$

$0^\circ \leq x \leq 180^\circ$ , take the scale of

2cm for  $30^\circ$  on the x-axis

2cm for 1 unit on the y-axis

c) use the graph in (b) above too solve the equation  $2\sin x^\circ + \cos x^\circ = 1$  and determine the range of values of  $x$  for which  $2\sin x^\circ = 1 - \cos x^\circ$

11. Solve the equation  $2 \sin (x + 30) = 1$  for  $0 \leq x \leq 360$ .

12. (a) Complete the table below, giving your values correct to 1 decimal place

$x$	$0^\circ$	$10^\circ$	$20^\circ$	$30^\circ$	$40^\circ$	$50^\circ$	$60^\circ$	$70^\circ$	$80^\circ$	$90^\circ$	$100^\circ$	$110^\circ$	$120^\circ$	$130^\circ$	$140^\circ$	$150^\circ$	$160^\circ$	$170^\circ$	$180^\circ$
$10 \sin x$	0	-	3.4	5.0		7.7		9.4	9.8	10	9.8	9.4		7.7		5.0	3.4		0

(b) Draw a graph of  $y = 10 \sin x$  for values of  $x$  from  $0^\circ$  to  $180^\circ$ . Take the scale 2cm represents  $20^\circ$  on the x-axis and 1cm represents 1 unit on the y axis

(c) By drawing a suitable straight line on the same axis, solve the equation: -  
 $500 \sin x = -x + 250$

12. Complete the table below for the functions  $y = \cos x$  and  $y = 2 \cos (x - 30)$  for  $0 \leq x \leq 360$

$x$	$0^\circ$	$30^\circ$	$60^\circ$	$90^\circ$	$120^\circ$	$150^\circ$	$180^\circ$	$210^\circ$	$240^\circ$	$270^\circ$	$300^\circ$	$330^\circ$	$360^\circ$
$\cos x$	1	0.87	0.5		-0.5	-0.87	-1.0		0.5	0		0.87	1
$2 \cos (x - 30^\circ)$	1.73		0	-1.0		-2.0	-1.73	-1.0		1	1.73	2.00	1.73

(a) On the same axis, draw the graphs of  $y = \cos x$  and  $y = 2 \cos (x - 30)$  for  $0 < x < 360^\circ$ .

(b) (i) State the amplitude of the graph  $y = \cos x^\circ$ .

(ii) State the period of the graph  $y = 2 \cos (x + 30^\circ)$ .

c) Use your graph to solve

$$\cos x = 2 \cos (x + 30^\circ)$$

13. Solve the equation  $\sin(2\theta + 10) = -0.5$   
for  $0 \leq \theta \leq 2\pi$

14. Solve the equation  
 $4 \sin 2x = 5 - 4 \cos^2 x$  for  $0^\circ \leq x \leq 360^\circ$

15. (a) Complete the table given below by filling in the blank spaces

$x$	0	15	30	45	60	75	90	105	120	135	150	165	870
$4 \cos 2x$	4.00		2.00	0	-2.00	-3.46	-4.00	-3.46	-2.00	0	2.00		4.00
$2 \sin (2x + 30^\circ)$	1.00	1.73	2.00	1.73		0	-1.00	-1.73	-2.00	-1.73		0	1.00

- (b) On the grid provided; draw on the same axes, the graphs of  $y = 4\cos 2x$  and  $y = 2\sin(2x + 30^\circ)$  for  $0^\circ \leq x \leq 180^\circ$ . Take the scale: 1cm for  $15^\circ$  on the x-axis and 2cm for 1 unit on the y-axis
- (c) From your graph:-
- State the amplitude of  $y = \cos 2x$
  - Find the period of  $y = 2\sin(2x + 30^\circ)$
- (d) Use your graph to solve:-  
 $4\cos 2x - 2\sin(2x + 30^\circ) = 0$

### 59. Three dimensional geometry

1. The figure below represents a plan of a roof with a rectangular base ABCD. AB = 20cm and BC = 12cm. the ridge PQ = 8cm is centrally placed. The faces ADP and BCQ are equilateral triangles. N is the mid-point of BC

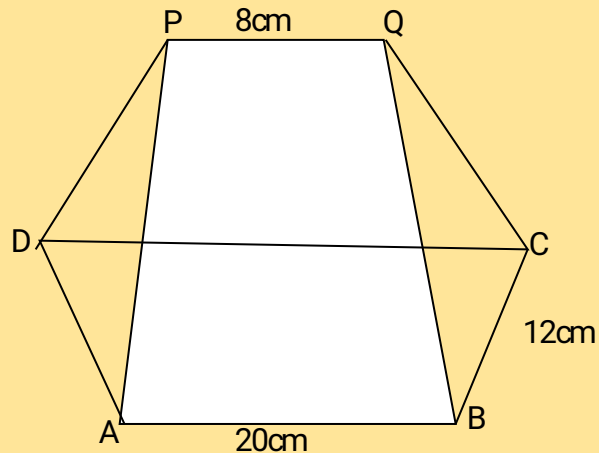

Calculate:

- QN
- The altitude of P above the base
- The angle between the planes ABQP and ABCD
- (i) Locus P and locus Q meet at X. Mark X  
 (ii) Construct locus R in which angle BRC is  $120^\circ$   
 (iii) Show that locus inside triangle ABC such that  $XS \geq R$

2.

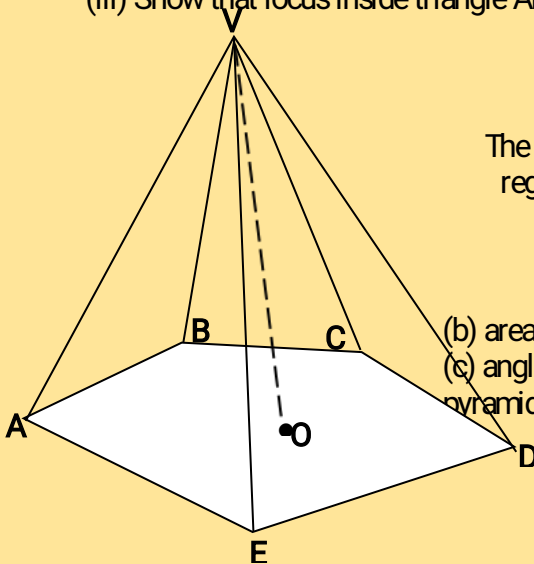

The diagram alongside shows a right pyramid whose base is a regular pentagon of side 10cm.  $VA = VB = VC = VD = VE = 18.2$ cm and O is the centre of the pyramid. Calculate;

- height of the pyramid
- area of the pentagon
- angle between the face VAB and the base of the pyramid
- The pyramid is a container filled with orange juice. Calculate the amount of juice in it.
- find the surface area of the face VCD

3. The diagram below shows a right pyramid on a rectangular base ABCD measuring 7.5cm by 4.2cm

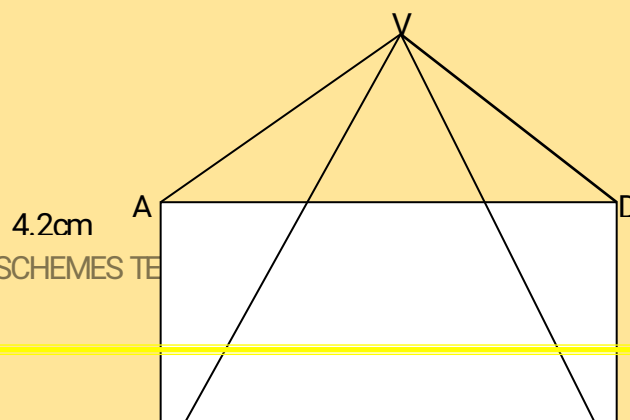



If the volume of the pyramid is  $52.5\text{cm}^3$ , find:-

- The height of the pyramid
- The length of a slanting edge correct to 1 decimal place
- The angle between AV and CV
- The obtuse angle between the edges AB and VD

4. The figure below is cuboid ABCDEFGH.  $AB = 12\text{cm}$ ,  $BC = 5\text{cm}$ ,  $CF = 6.5\text{cm}$

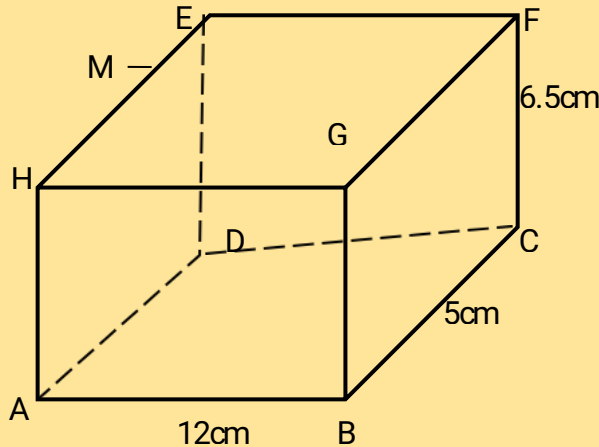

Calculate:

- the length BD
- the angle AF makes with the base ABCD
- the angle DHGC makes with the base ABCD
- M is the mid-point of HE. Calculate the length of line MC and the angle line MC makes with the base ABCD

5. The figure below is a right pyramid with a rectangular base ABCD and vertex V.

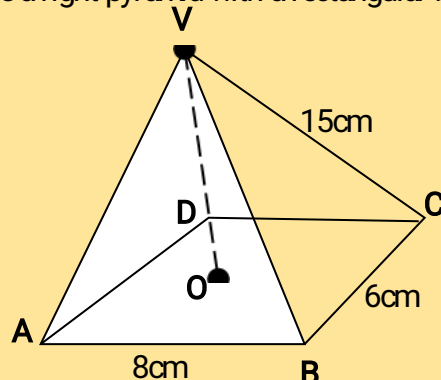

O is the centre of the base and M is a point on OV such that  $OM = \frac{1}{3} OV$ ,  $AB = 8\text{cm}$ ,  $BC = 6\text{cm}$  and  $VA = VB = VD = VC = 15\text{cm}$ . Find;

- The height OV of the pyramid.
- The angle between the plane BMC and base ABCD.

6. The figure below represents a right pyramid with vertex V and a rectangular base PQRS,  $VP = VQ = VR = VS = 18\text{cm}$ ,  $PQ = 16\text{cm}$  and  $QR = 12\text{cm}$ . M and O are the midpoints of QR and PR respectively.

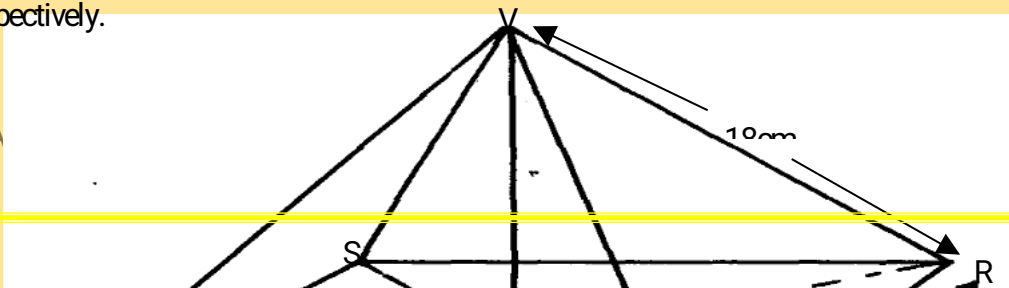



**Find:**

- a) the length of the projection of the line VP on the plane PQRS
- b) the size of the angle between line VP and the plane PQRS
- c) the size of the angle between plane VQR and PQRS

7. Mayoni Municipal Council wishes to construct a monument on the grounds. The monument is designed to be in the shape of a frustum of a right pyramid. The base of the frustum is a square of side 5.5 meters while the top of the frustum is a square of side 2.1 cm

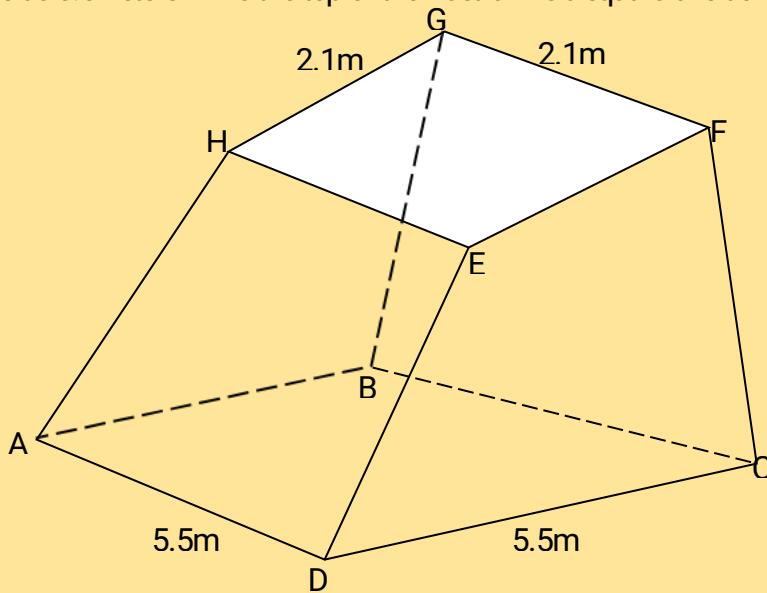

If the perpendicular distance between faces ABCD and EFGH is 7m;

- (a) find the surface area of the monument frustum
- (b) The monument is to be painted on all surface excluding the base. Paint is sold in 4 litre tins each costing Kshs.640/=. It is estimated that an area  $10m^2$  is painted by  $\frac{1}{2}$  litre of paint, find the cost of painting the monument.

8. The figure below is a pyramid of a rectangular base PQRS of length 12cm and width 9cm. The slanting edge has a length of 19.5cm

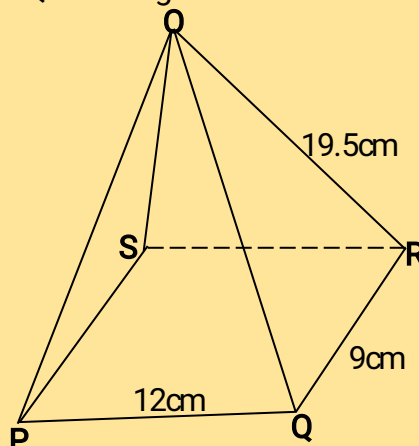

- (a) Determine the height of the pyramid
- (b) The angle PO makes with base PQRS
- (c) The angle POS makes with QOR
- (d) The volume of the pyramid

9. The diagram below shows a right solid pyramid on a square base ABCD of side 12cm and

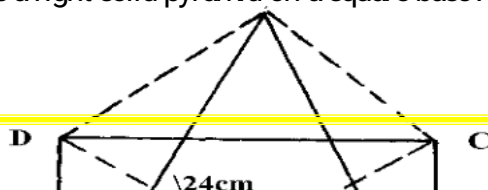

slanting height of 24cm

Calculate;

- a) To two decimal place the height ( $VO$ ) of the pyramid
- b) the volume of the pyramid
- c) the total surface area of the pyramid

10. The base of a pyramid consists of a regular pentagon **ABCDE**, **4.5cm** a side. The vertex of the pyramid is **V** and  **$VA = VB = VC = VD = VE = 6.4cm$**
- (a) Sketch the general view of the pyramid
  - (b) Calculate:
    - (i) The angle between **VA** and the base
    - (ii) The angle between face **VCD** and the base
11. The positions of two towns A and B on earth's surface are ( $60^\circ N, 139^\circ E$ ) and ( $60^\circ N, 41^\circ W$ ) respectively
- a) Find the difference in longitude between A and B
  - b) Given that the radius of the earth is 6370km, calculate the distance between A and B in KM
  - c) Another town C is 420km East of town B and on the same latitude A and B find the longitude of town C

## 60. Longitudes and latitudes

1. The latitude and longitude of two stations **P** and **Q** are ( $47^\circ N, 25^\circ W$ ) and ( $47^\circ N, 70^\circ W$ ) respectively. Calculate the distance in nautical miles between **P** and **Q** along the latitude  $47^\circ N$
2. A plane leaves an airport **P** ( $10^\circ S, 60^\circ E$ ) and flies due north at 800km/hr. By taking radius of the earth to be 6370-km and 1 nautical mile to be 1.853km
  - (a) Find its position after 2hrs
  - (b) The plane turns and flies at the same speed due West to reach **Q** longitude  $12^\circ W$ . Find the distance it has traveled due in West nautical miles
  - (c) Find the time it has taken
  - (d) If the local time at **P** was 1300hrs when it reached **Q**. Find the local time at **Q** when it landed at **Q**
3. Bot juice company has two types of machines, A and B, for juice production  
Type A machine can produce 800 litres per day while type B machine produces 1600 litres per day.  
Type A machine needs 4 operators and type B machine needs 7 operators  
At least 8000 litres must be produced daily and the total number of operators should not exceed 41. There should be 2 or more machines of each type. Let  $x$  be the number of machines of type A and  $y$  the number of machines for type B,
  - a) Form all inequalities in  $x$  and  $y$  to represent the above information
  - b) On the grid provided below, draw the inequalities and shade the wanted regions
  - c) Use the grid in (b) to determine the least number of operators required for the maximum possible production

4. Points **R** and **S** are two points on the surface on a latitude  $48^\circ$  S. The two points lie on longitudes  $30^\circ$  W and  $150^\circ$  E respectively. By taking the earth's radius to be 6370km, calculate:
- The distance from **R** to **S** along a parallel of latitude.
  - An aeroplane flies at an average speed of 280km/h from **R** to **S** along a great circle through the South Pole. Calculate the total time taken.
  - The local time of **R** when the local time of **S** is 2.15pm.
  - Another point **Q** is 600Nm North of **R**. Find the location of **Q**.
5. A jet flies from  $34^\circ$ N,  $12^\circ$ E to  $(34^\circ$ E,  $24^\circ$ E) in  $1\frac{1}{2}$  hrs. Find its average speed in knots
- P** and **Q** are two points on a geographical globe of diameter 50 cm. They both lie on a parallel latitude  $50^\circ$  North. **P** has longitude  $90^\circ$  West and **Q** has longitude  $90^\circ$  East. A string **AB** has one end at point **P** and another at point **Q** when it is stretched over the North pole. Taking  $\pi = 3.142$ ;
- Calculate the length of the string.
  - If instead the string is laid along the parallel of latitude  $50^\circ$ N with **A** at point **P**, calculate the longitude of point **B**.
  - State the position of **B** if the string is stretched along a great circle of **P** towards the South pole if point **A** is static at **P**.
7. Two points **A**( $70^\circ$ ,  $15^\circ$ E) and **B** lie on the same circle of latitude on the earth's surface. Given that the shortest distance between the two points along the circle of latitude is 2133.6km. Giving coordinates to the nearest degree, find the location of **B**.  
(Take  $\pi = \frac{22}{7}$  and radius of earth = 6380km)

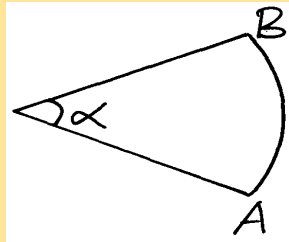

8. The position of two towns **A** and **B** on the earth's surface are ( $36^\circ$ N,  $49^\circ$ E) and ( $36^\circ$ N,  $131^\circ$ W) respectively (Earth's radius = 6370km and  $\pi = \frac{22}{7}$ ):-
- Find the longitudinal difference between the two towns
  - Calculate the distance between the towns:-
    - Along a circle of latitude (in km)
    - Along the great circle in km and nautical miles
  - Another town **C**, is 840km due East to town **B**. Locate the position of town **C**
9. **P**, **Q** and **R** are points on the surface of the earth such that **P**( $60^\circ$ N,  $20^\circ$ W), **Q**( $60^\circ$ S,  $20^\circ$ W) and **R**( $60^\circ$ N,  $80^\circ$ E) find:
- The shortest distance between **P** and **Q** on the surface of the earth in kilometres and nautical miles(nm)
  - The length of latitude  $60^\circ$ N and hence the length of the minor arc **PR** in kilometres
  - The distance from **P** to the North Pole
10. A jet flies from town **X**( $50^\circ$ S,  $20^\circ$ E) directly to **Y**( $50^\circ$ S,  $28^\circ$ W) and then due South for 1200m to **Z**
- (i) Find the latitude of **Z**
  - (ii) Calculate the distance **XY** along a parallel of latitude  $50^\circ$ S in km
  - (b) (i) Given that the average speed of the jet is 400 knots, calculate the time taken to reach **Z** from **X** to the nearest 0.1 hour
  - (ii) Find the time of arrival at **Z** given that the plane left **X** at 7.40a.m. Take  $\pi = \frac{22}{7}$  and radius of the earth to be 6370km
11. A jet on a rescue mission left town **A**( $35^\circ$ S,  $15^\circ$ E) to town **B**( $45^\circ$ N,  $15^\circ$ E) and then to town **C**( $45^\circ$ N,  $45^\circ$ W). If **BC** subtends  $60^\circ$  and the radius of the earth is 6370km. Find;
- the distance in nautical miles from **A** to **C** via **B** correct to 4 s.f

- (b) the distance in kilometers from A to B to the nearest km  
 (c) the jet flew at 840km/h from A to C. If the jet left town A at 8.15a.m, what time will it arrive at town C in local time

## 61. Linear programming

1. A man bakes two types of cakes, queen cakes and marble cakes. Each week he bakes  $x$  queen cakes and  $y$  marble cakes. The number of cakes baked are subject to the following conditions;  $30x + 20y \leq 4800$ ,  $30x + 40y \geq 3600$  and  $10x > 30y$   
 He makes a profit of shs.10 on each queen cake and shs.12 on each marble cake.
  - (i) Draw a graph to represent the above information on the grid provided
  - (ii) From the graph, determine how many cakes of each type he should make to maximize his weekly profit
  - (iii) Calculate the maximum profit
  - (iv) If he is to make a weekly profit of at least shs.600, find the least number of marble cakes he should bake
  
2. A company produces shirts and jerseys using two types of machines. Every shirt made requires 2 hours on machine **A** and 2 hours on machine **B**. Every Jersey made requires 3hours on machine **A** and 1 hour on machine **B**. In one day the time limit on machine **A** is 24hours but that on machine **B** is 12hrs. The number of Jerseys produced must not be more than the shirts produced in one day. The company makes a profit of shs.200 on each shirt and shs.200 on each Jersey. The company produces  $x$  shirts and  $y$  jerseys per day
  - (a) Write down four inequalities which must be satisfied by  $x$  and  $y$  and represent these inequalities on a grid
  - (b) Find the values of  $x$  and  $y$  which will give the company maximum daily profit and also state the maximum profit
  
3. A trader makes two types of chair, ordinary and special chairs. The cost of each ordinary chair is shs.300 while each special chair costs shs.700. He is prepared to spend not more than shs.21,000. It is not viable for him to make less than 20 chairs. Ordinary chairs must be less than twice the special chairs but more than 15. By taking the number of ordinary chairs as  $x$  and special chairs as  $y$ :
  - (a) Write down all the inequalities in  $x$  and  $y$
  - (b) Draw the inequalities on the grid provided
  - (c) He sells a special chair at a profit of shs.140 while ordinary chairs at a profit of shs.120; Determine the maximum possible profit
  
4. A school has to take 384 people for a tour. There are two types of buses available. Type X and type Y. Type X can carry 64 passengers and type Y can carry 48 passengers. They have to use at least 7 buses.
  - a) Form all linear inequalities which will represent the above information
  - b) On the grid provided, draw the inequalities and shade the un-wanted region.
  - b) The charges for hiring the buses are ;
    - Type X: shs.25,000
    - Type Y: shs.20,000
 Use your graph to determine the number of buses of each type that should be hired to minimize the cost.
  
5. A shoe maker makes two types of shoes **A** and **B**. He takes 3 hours to make one pair of type **A** and 4 hours to make one pair of type **B**. He works for a maximum of 120 hours to make  $x$  pairs of type **A** and  $y$  pairs of type **B**. It costs him Kshs. 400 to make a pair of type **A** and Kshs.150 to make a pair of type **B**. His total cost does not exceed kshs.9000. He must make at least 8 pairs of type **A** and 12 pairs of type **B**.
  - (a) Write down four inequalities representing the information above
  - (b) On the grid provided represent the inequalities and shade the unwanted regions

- (c) The shoe maker makes a profit of kshs.40 on each pair of type **A** and kshs.70 on each pair
6. A theatre has a seating capacity of 250 people. The charges are shs.100 for an ordinary seat and shs.160 for a special seat. It costs shs.16,000 to stage a show and the theatre must make a profit. There is never more than 200 ordinary seats and for a show to take place at least 50 ordinary chairs must be occupied. The number of special seats is always less than twice the number of ordinary seats.
- taking  $x$  to be the number of ordinary seats and  $y$  the number of special seats, write down all the inequalities representing the information above.
  - On the grid provided, draw the graph to show the inequalities in (a) above
  - Determine the number of seats of each type that should be booked in order to maximize the profit.
7. A man sells two types of ice creams in cups and sticks. He can store less than ten packets in his cooling box. He sells more cups than sticks but less than 3 items as many cups as sticks. He also knows that he will sell more than 3 packets of sticks. His profit is shs.3.00 on a packet of cups and shs.2.00 on a packet of sticks.
- Form inequalities to represent the above information:  
(Let  $x$  – packets of cups and  
 $y$  – packets of sticks)
  - On the grid provided graph the inequalities to satisfy the required condition
  - How many packets of cups and sticks should the man put in his box to give him the highest profit?
8. A shopkeeper bought 50 pangas and 30 jembes :-
- From a wholesaler for shs.4,260. He had bought half as many jembes and 5 pangas less, he would have paid shs.1290 less. Had the shopkeeper bought from wholesaler **B**, he would have paid 10% more a panga and 15% less for a jembe. How much would he have saved if he had bought the 50pangas and 30 jembes from wholesalers **B**
  - The price of a suit if marked at shs.5000. A discount
9. The games master wishes to hire two matatus for a trip. The operators have a Toyota which carries 10passengers and a Kombi which carries 20 passengers. Altogether 120 people have to travel. The operators have only 20litres of fuel and the Toyota consumes 4 litres on each round trip and the Kombi 1 litre on each round trip. If the Toyota makes  $x$  round trips and the kombi  $y$  round trips;
- write down four inequalities in  $x$  and  $y$  which must be satisfied

b) represent the inequalities graphically on the grid provided

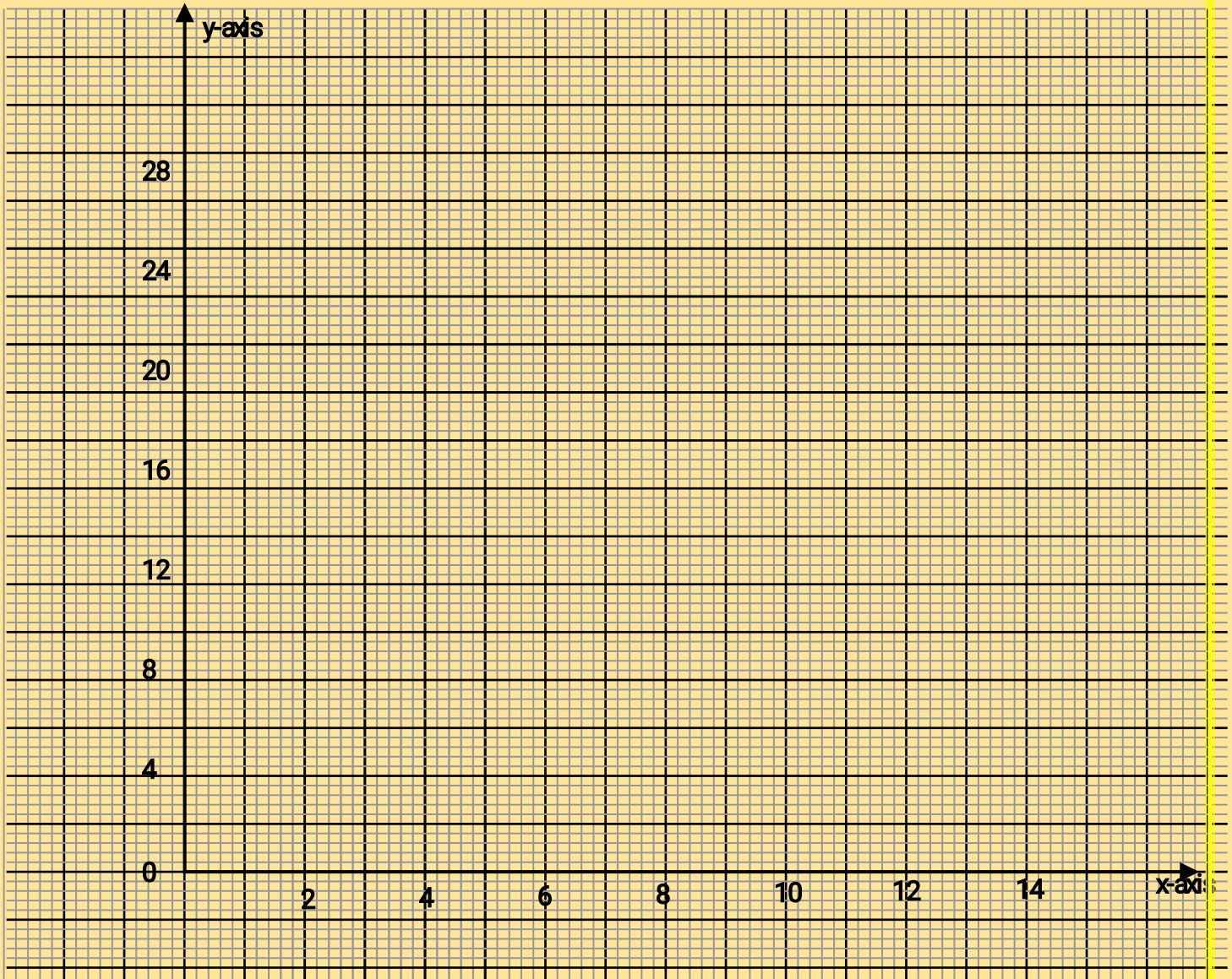

(c) The operators charge shs.100 for each round trip in the Toyota and shs.300 for each round trip in the kombi;

(i) determine the number of trips made by each vehicle so as to make the total cost a Minimum

(ii) find the minimum cost

10. The velocity of a particle  $V$ m/s moving in a straight line after  $t$  seconds is given by  $V = 3t^2 - 3t - 6$ . Find the distance covered by the particle between  $t = 1$  and  $t = 4$ seconds

## 62. Differentiation

1. A particle moves in a straight line from a fixed point. Its velocity  $V$ m/s after  $t$  seconds is given by  $v = 9t^2 - 6t + 2$  calculate the distance traveled by the particle during the 2<sup>nd</sup> second. (4 mks)
  
1. A particle moves such that  $t$  seconds after passing a given point  $O$ , its distance  $S$  metres from  $O$  is given by  $S = t(t-2)(t-1)$ 
  - (a) Find its velocity when  $t = 2$  seconds
  - (b) Find its minimum velocity
  - (c) Find the time when the particle is momentarily at rest



(d) Find its acceleration when  $t = 3$  seconds

2. The table below gives the values of  $x$  and  $y$  for the curve  $y = x^2 + 1$

X	0	1	2	3	4	5	6	7	8	9	10
y	1	2		10	17		37	50		82	

a) Complete the table

b) Use the mid-ordinate rule to estimate the area enclosed by the curve  $y = x^2 + 1$ .

Use five ordinates

c) Using integration, calculate the actual area in (a) above

d) Calculate the percentage error in the estimated area

3. The gradient function of a curve is given by the expression  $2x + 1$ . If the curve passes through the point  $(-4, 6)$ ; find the equation of the curve

4. A particle **P** moves in a straight line so that its velocity,  $V$  m/s at time  $t$  seconds where  $t \geq 0$  is given by  $v = 28 + t - 2t^2$

**Find;**

(a) the time when **P** is instantaneously at rest

(b) the speed of **P** at the instant when the acceleration of **P** is zero

(c) Find the acceleration of **P** when the article is instantaneously at rest

(d) Find the distance covered by the particle during the 3<sup>rd</sup> second, when at  $t = 0$   $D = 5M$

5. A particle **K** moves along a straight line 50 cm long. At time  $t = 0$ , **k** is at **A** and  $t$  seconds later its velocity  $v$  cm/s is given by  $v = 15 + 4t - 3t^2$ .

a) Write down the expression for;

i) The acceleration of **K** at time  $t$  seconds.

ii) The distance of **K** from **A** at time  $t$  seconds.

b) i) Find  $t$  when **K** is instantaneously at rest.

ii) How far is **K** from **A** at this time?

c) Find the period of time during which the acceleration of **P** is positive.

6. The diagram below shows the sketch of the curve  $y = x^2$  and  $y = -x^2 + 8$  intersecting at **A** and **B**:-

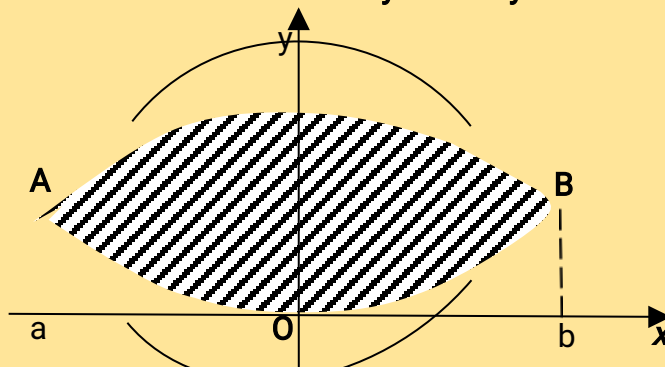

(a) Find the value of **a** and **b** hence find the coordinates of **A** and **B**

(b) Find the area enclosed by  $x = a$ ,  $x = b$ , the axis and:-

(i) the curve  $y = x^2$

(ii) the curve  $y = -x + 8$

7. The distance from a fixed point of a particle in motion at any time  $t$  seconds is given by :-  
 $S = t^3 - \frac{5}{2}t^2 + 2t + 5$  metres

Find its:

(a) Acceleration after  $t$  seconds

(b) Velocity when acceleration is zero

8. A particle moves in a straight line. It passes through point **O** at  $t = 0$  with a velocity  $v = 5$  m/s. The acceleration  $a$  m/s<sup>2</sup> of the particle at time  $t$  seconds after passing through **O** is given by

$$a = 6t + 4$$

(a) Express the velocity  $v$  of the particle at time  $t$  seconds in terms of  $t$ .

- (b) Calculate the velocity of the particle when  $t = 4$ .  
 (c) (i) Express the displacement  $s$  by the particle after  $t$  seconds in terms of  $t$ .  
 (ii) Calculate the distance covered by the particle between  $t = 1$  and  $t = 4$ .

9. The displacement  $S$  metres of a particle moving along a straight line after  $t$  seconds is given by.  

$$S = 3t + \frac{3t^2}{2} - 2t^3$$

a) Find its initial acceleration

b) Calculate:

- i) The time when the particle was momentarily at rest  
 ii) Its displacement by the time it came to rest momentarily

c) Calculate the maximum speed attained

10. Find the equation to the tangent to the curve:-  
 $y = 4x^3 - 2x^2 - 3x + 5$  at the point (2, 23)

11. A farmer wanted to make a trough for cows to drink water. He had a metal sheet measuring 240cm by 120cm and 1cm thick. The density of the metal is  $2.5\text{g/cm}^3$ . A square of sides 30cm is removed from each corner of the rectangle and the remaining part folded to form an open cuboid.

(a) Sketch the sheet after removing the squares for the four corners, showing all the dimensions

(b) Calculate:-

- (i) The area of the metal which forms the cuboid  
 (ii) The mass of the empty cuboid in Kilograms

(b) The cuboid is filled with water whose density is  $1\text{g/cm}^3$ . Calculate the mass of the cuboid when full of water

12. A rectangular sheet of cardboard is 8cm long and 5cm wide. Equal squares are cut away at each corner and the remainder is folded so as to form an open box. Find the maximum volume

13. (a) Find the equation of the normal to the curve :-  $y = x^3 - 2x - 1$  at (1, -2)

(b) Determine the nature of the turning points to the curve  $y = x^3 - 3x + 2$ ; Hence in the space provided below, sketch the curve

14. A particle moves in a straight line so that its velocity,  $v/\text{m/s}$  at time  $t$  seconds where  $t \geq 0$  is given by  $v = 28 + t - 2t^2$

Find:-

- (a) The time when  $P$  is instantaneously at rest  
 (b) The speed of  $P$  at the instant when the acceleration of  $P$  is zero  
 (c) Given that  $P$  passes through the point  $O$  of the line when  $t = 0$ ;  
 (i) Find the distance of  $P$  from  $O$  when  $P$  is instantaneously at rest

15. A particle moves such that  $t$  seconds after passing a given point  $O$ , its distance  $S$  metres from  $O$  is given by  $S = t(t-2)(t-1)$



- (a) Find its velocity when  $t = 2$  seconds
- (b) Find its minimum velocity
- (c) Find the time when the particle is momentarily at rest
- (d) Find its acceleration when  $t = 3$  seconds

### 63. Approximation of area

- Use trapezoidal rule to estimate the area bounded by the curve  $y = 8 + 2x - x^2$  for  $-1 \leq x \leq 3$  using 5 ordinates
- Using trapezoidal rule, estimate the area under the curve  $y = \frac{1}{2}x^2 - 2$  between  $x = 2$  and  $x = 8$  and x-axis. Use six strips
  - Use integration to evaluate the exact area under the curve
    - Find the percentage error in calculating the area using trapezoidal rule
- Using trapezoidal rule, estimate the area under the curve  $y = \frac{1}{2}x^2 - 2$  between  $x = 2$  and  $x = 8$  and x-axis. Use six strips
  - Use integration to evaluate the exact area under the curve
    - Find the percentage error in calculating the area using trapezoidal rule
- The figure below shows the graphs of  $y = 2x + 3$  and  $y = -x^2 + 3x + 4$

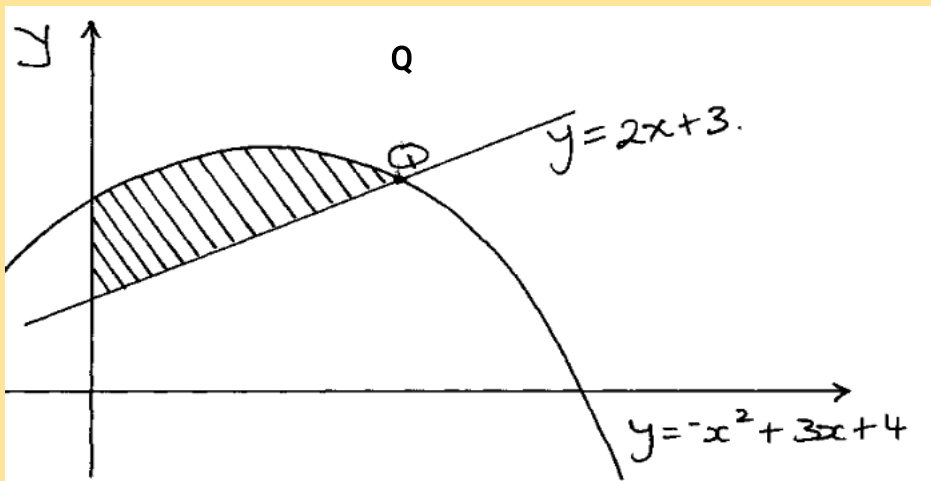

- determine the co-ordinates of Q, the intersection of the two graphs
- Find the exact area of the shaded region

5. The table below shows some values of the function;  $y = x^2 + 2x - 3$  for  $-6 \leq x \leq -3$

x	-6	-5.75	-5.5	-5.25	-5	-4.75	-4.5	-4.25	-4.0	-3.75	-3.5	-3.25	-3
y	21	18.5		14.0		10.0	8.25		5		2.25	1.06	0

- complete the table
  - using the completed table and the mid-ordinate rule with six ordinates, estimate the area of the region bounded by the curve;  $y = x^2 + 2x - 3$  and the lines  $y = 0$ ,  $x = -6$  and  $x = -3$
  - by integration find the actual area of the region in (b) above
    - Calculate the percentage error arising from the estimate in (b)
- 6 Complete the table below for  $y = 5x^2 - 2x + 2$ . Estimate the area bounded by the curve, the x-axis, the lines  $x = 2$  and  $x = 7$  using the trapezoidal rule with strips of unit length.

x	2	2.5	3	3.5	4	4.5	5	5.5	6	6.5	7
y	18			56.25	74		117			200.25	

### 6. Integration

- Evaluate: 
$$\int_2^5 \frac{x^2 - 3x + 2}{x - 2} dx$$

2. Find the values of  $a$  which satisfy the integral  
 $\int_0^1 (x^2 + 1) dx = 2a$

**FOR ALL MARKING  
SCHEMES TEXT OR CALL  
0724351706**