

071504T4WLD

WELDING - LEVEL 4

ENG/OS/WEF/CR/04/4/A

Perform Gas Welding In All Positions With Various Metal Work Pieces

March/April 2025



**TVET CURRICULUM DEVELOPMENT, ASSESSMENT AND CERTIFICATION COUNCIL
(TVET CDACC)**

PRACTICAL ASSESSMENT

TIME: 6 HOURS

INSTRUCTIONS TO CANDIDATE:

1. You are required to perform the following tasks:
 - i. Prepare and produce the component as shown in the working drawing.

2. You have been provided with the following resources for the practical tasks:
 - Mild Steel plates
 - $92 \times 47 \times 4$ 1 off
 - $102 \times 92 \times 4$ 1 off
 - $92 \times 52 \times 4$ 1 off
 - $92 \times 62 \times 4$ 1 off
 - Mild Steel pipe
 - $\varnothing 50 \times 72$ gauge 16 1 off

- Mild Steel filler wires (3 off)
- Complete gas welding equipment with accessories
- Pair of tongs
- Angle gauge
- Ballpein hammer
- Steel rule
- Assorted files
- Try square
- Pliers
- Wire Brush
- Dividers
- Hack saw frame fixed
- Hack saw blade
- Bench vice
- Assorted spanners
- S.S tape flexible in case
- Pedestal grinder
- Portable angle grinder
- Scriber
- Grinding and cutting discs
- Clean cloth or rag
- Welding shield/helmet, goggles, leather gloves
- Welding fixture

WORKING DRAWING

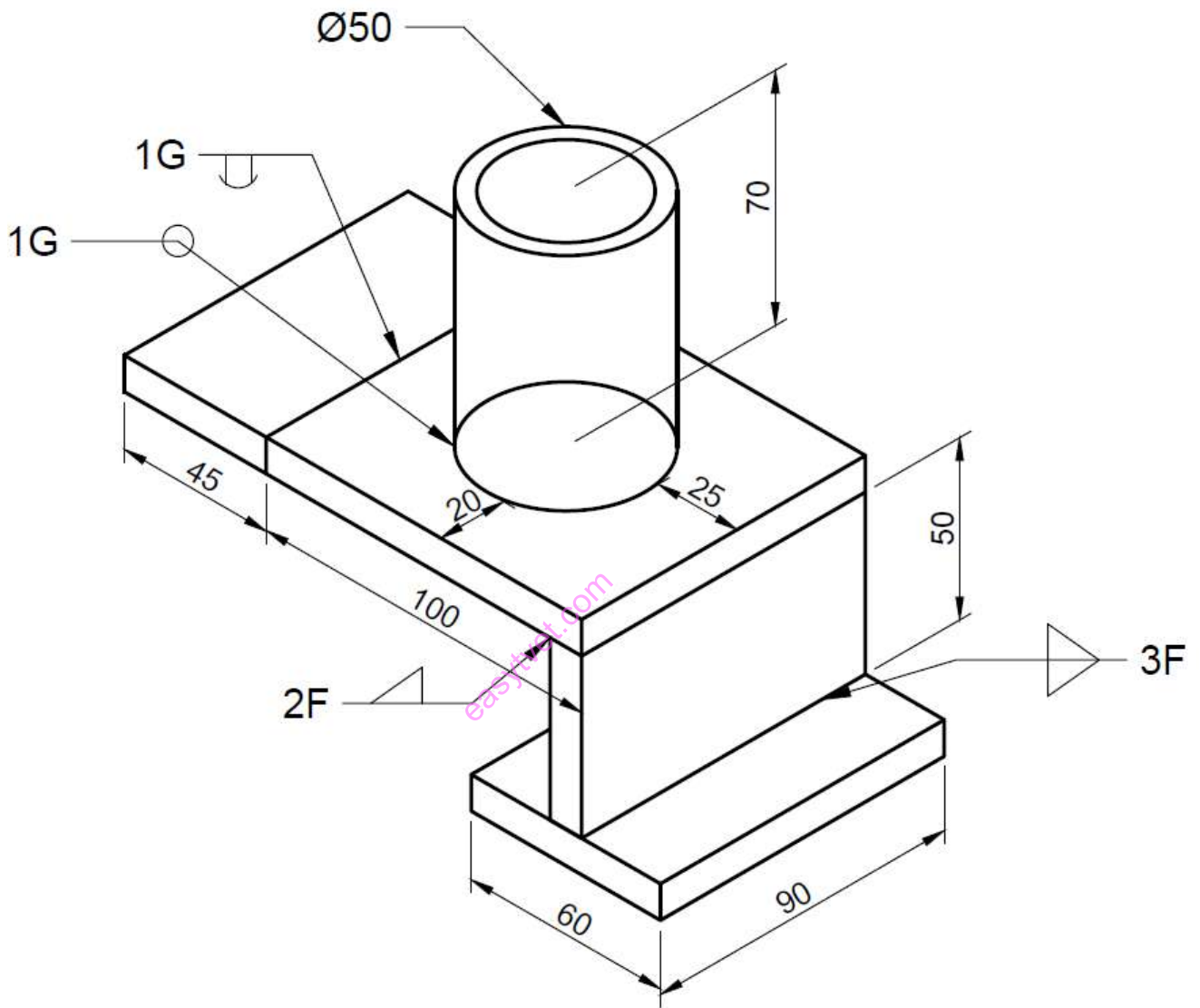

NOTES

Drawings not drawn to scale

All dimensions are in millimeters (mm)

Tolerance: ± 1 mm