

071504T4WLD

WELDING LEVEL 4

ENG/OS/WEF/CR/03/4/A

Perform MIG Welding in all Positions with Various Metal Work Pieces

March/April 2025



**TVET CURRICULUM DEVELOPMENT, ASSESSMENT AND CERTIFICATION COUNCIL
(TVET CDACC)**

PRACTICAL ASSESSMENT

TIME: 6 HOURS

INSTRUCTIONS TO CANDIDATE:

1. You are required to perform the following tasks
 - i. Prepare and produce the component as per the working drawing.
2. You are provided with the following resources:
 - Mild Steel plate:
 - $102 \times 102 \times 4$ (2 off)
 - $102 \times 62 \times 4$ (2 off)
 - Mild steel pipe (gauge 16)
 - $\varnothing 50 \times 102$ (2 off)
 - Angle gauge
 - Welding helmet/shield
 - Leather gloves
 - A4 plain paper

- Scriber
- Hacksaw
- Angle grinder
- Grinding and cutting disc
- Complete MIG welding machine with accessories
- Chipping hammer
- Metal wire brush
- Bench vice
- Pair of tongs
- Chalk
- Divider
- Ballpein hammer
- Steel rule
- Assorted files
- Engineer's square
- Anvil
- Welding fixture
- Vernier calliper
- Flat chisel
- Files
- Cleaning brushes

easytvvet.com

WORKING DRAWING

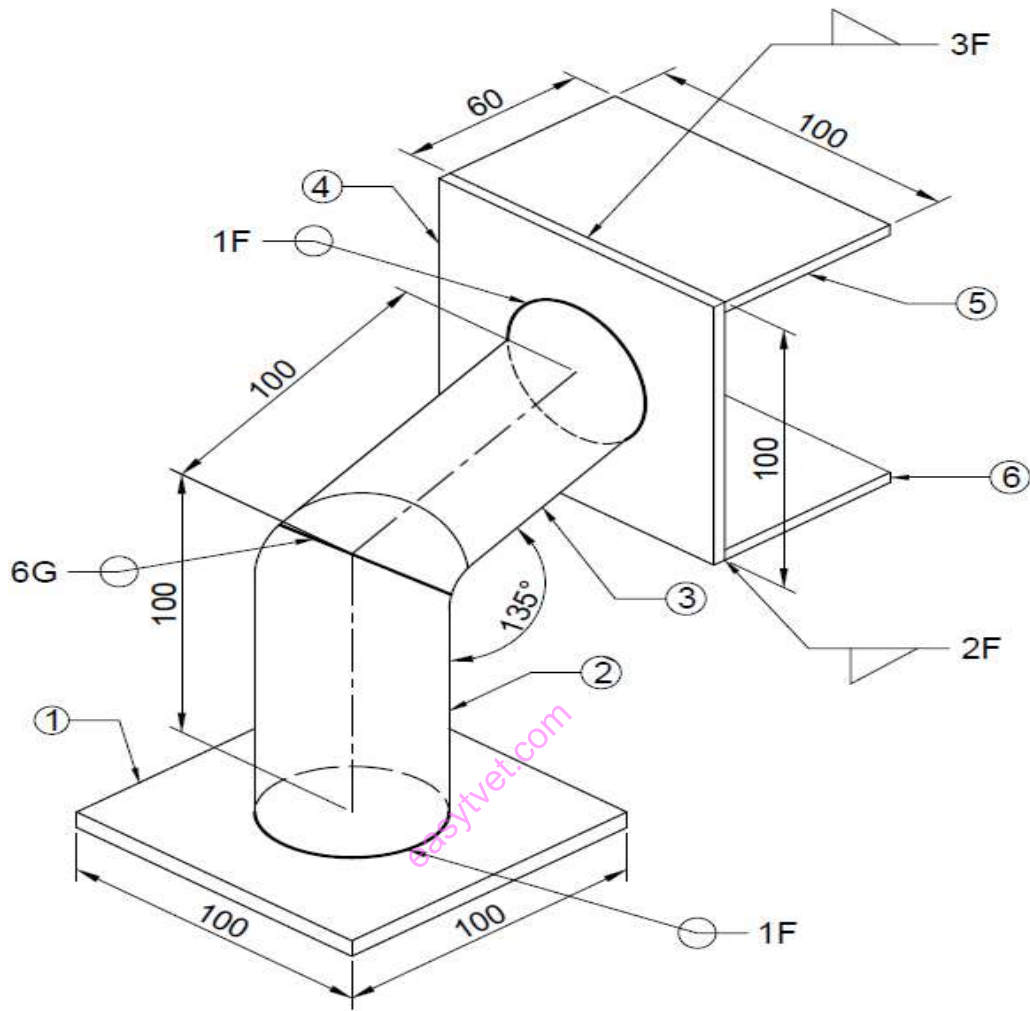

NOTE:

All dimensions are in millimetres (mm)

Linear tolerance ± 1