

071304T4EIN

ELECTRICAL INSTALLATION LEVEL 4

ENG/OS/EI/CC/03/4/A

APPLY ELECTRICAL PRINCIPLES

November/December 2025



**TVET CURRICULUM DEVELOPMENT, ASSESSMENT AND CERTIFICATION
COUNCIL (TVET CDACC)**

WRITTEN ASSESSMENT

Time: 2 HOURS

INSTRUCTIONS TO CANDIDATE

1. This paper consists of **TWO** sections **A** and **B**.
2. Answer **ALL** the questions in each section.
3. Marks for each question are indicated in the brackets.
4. You are provided with a separate answer booklet to answer the questions.
5. Do not write on the question paper.

This paper consists of FIVE (5) printed pages
Candidates should check the question paper to ascertain that all pages
are printed as indicated and that no questions are missing

SECTION A (10 MARKS)

Attempt all questions. Each question carries one mark

1. Ohm's law is a fundamental principle used to design electrical systems. State Ohm's law.
 - A. Sum of resistances of individual components in a circuit is the equivalent resistance of the circuit provided voltage is kept constant.
 - B. The current flowing in a circuit is directly proportional to the applied voltage and inversely proportional to resistance provided temperature is kept constant
 - C. The current flowing in a circuit is directly proportional to load resistance and inversely proportional to the applied voltage provided temperature is kept constant
 - D. The load resistance is determined by the amount of current flowing in the circuit
2. Identify among the following factors, one that does NOT affect resistance in a circuit.
 - A. Cross-sectional area
 - B. Resistivity
 - C. Temperature
 - D. Frequency of the AC current
3. Identify a statement that best describes the term Power Factor.
 - A. The ratio of resistance to capacitance in R-L-C circuits
 - B. The cosine of angle between voltage and current
 - C. The ratio of apparent power to true power
 - D. The ratio of impedance to resistance in R-L-C circuits
4. The current flowing in the branches of a D.C circuit may be determined using?
 - A. Kirchhoff's laws
 - B. Lenz's law
 - C. Faraday's laws
 - D. Fleming's left-hand
5. The following are reasons for installing lightning arrestors. Which one is NOT?
 - A. To prevent fire resulting from lightning strikes
 - B. To prevent electric surges from clouds that may damage an electrical installation
 - C. To prevent earth leakage current
 - D. To protect humans from electrocution from the lightning strike

6. A circuit has a resistance of $20\text{ k}\Omega$. Determine conductance of the same circuit.
- A. 50 S
 - B. 0.02 S
 - C. 0.02 mS
 - D. 20 Ks
7. Transformers are critical equipment used in transmission of electrical power. Among the following, identify one that is not a type of a transformer.
- A. Auto transformer
 - B. Step up transformer
 - C. Isolating transformer
 - D. Mechanical transformer
8. Identify the electrical quantify that is correctly matched with its SI unit.

	Quantity	Unit
A	Electric current	Volt
B	Electromotive force	Newton
C	Power	Watt
D	Impedance	Coulomb

9. Select a material used in constructing semiconductor devices.
- A. Copper oxide
 - B. Silicon
 - C. Aluminium
 - D. Ceramic
10. Capacitors are devices used to store electrical charges. Capacitors are classified mainly according to?
- A. Their size
 - B. Their colour
 - C. The dielectric material
 - D. Their tolerances

SECTION B: (40 MARKS)*Attempt all questions*

11. Calculate the resistance of a 200m length and cross-sectional area of 1.5mm^2 copper cable if the resistivity of copper is taken as 17.5×10^{-9} m. (3 Marks)
12. Give THREE advantages of DC motors over induction motors (3 Marks)
13. **Figure 1** shows the connections of a circuit with three resistors with their values as given and a 24V d.c power supply.

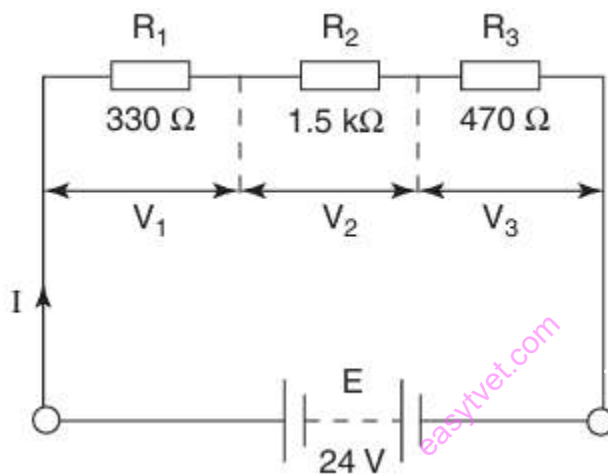
**Figure 1**

Determine;

- a. The total resistance in the circuit. (2 marks)
- b. The voltage across R_1 . (2 marks)
14. Name THREE components of an earthing system in electrical installation. (3 marks)
15. A resistor of $40\ \Omega$ and an inductor of $40\ \text{mH}$ are connected in series to a 110 V, 80Hz a. c supply. Calculate the value of current flowing through the resistor. (4 Marks)
16. Outline any THREE factors which affect the force on a current carrying conductor. (3 Marks)
17. List any FOUR practical type of capacitors (4 marks)
18. State Kirchhoff's laws. (4 marks)

19. A flux of $500\mu\text{wb}$ passing through a 200-turn coil is reversed in 40ms. Find the average emf induced (3 Marks)
20. Explain why Three Phase induction motor should be started through starters. (2 Marks)
21. Differentiate between Peak voltage V_P and R.M.S Voltage V_{RMS} and give the expression for their relationship as used in AC voltages. (3 Mark)
22. From the Power Triangle, give the expression for the following quantities (4 Marks)
- i. Apparent Power
 - ii. Real or Active Power
 - iii. Reactive Power
 - iv. Power Factor

easytvet.com